

2024
2025



MEASURING INSTRUMENTS

GATALOGUE NO. IN27

**BEST
SELLER**

←INSIZE→

PRODUCT INDEX

1 DATA OUTPUT

PAGE 1-4



DATA OUTPUT CABLES

2 CALIPERS

PAGE 5-23



CALIPERS

3 DEPTH MEASUREMENT

PAGE 24-29

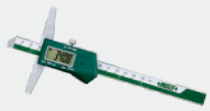

DEPTH GAGES



DEPTH GAGES



DEPTH MICROMETERS

4 HEIGHT MEASUREMENT

PAGE 30-34



DIGITAL HEIGHT GAGES



HEIGHT GAGES

5 COMPARISON INSTRUMENTS

PAGE 35-38



CARBON FIBER
COMPARISON GAGES



DIGITAL INTERNAL
MEASURING GAGES



INTERNAL AND EXTERNAL
DIAMETER COMPARISON
INSTRUMENTS



OUTSIDE DIAMETER
MEASURING STANDS

7 BORE DIAMETER, CIRCUMFERENCE MEASUREMENT

PAGE 53-61



INSIDE
MICROMETERS



INSIDE
MICROMETERS



THREE POINTS
INTERNAL MICROMETERS



BORE GAGES



TELESCOPING
GAGE SETS



CIRCUMFERENCE
METERS

6 MICROMETERS

PAGE 39-52



HIGH PRECISION DIGITAL
MICROMETERS/SNAP GAGES



OUTSIDE
MICROMETERS



3-WIRES



MICROMETER HEADS

8 ARC RADIUS MEASUREMENT

PAGE 62-66



OUTSIDE DIAMETER
MEASURING INSTRUMENTS



OUTSIDE DIAMETER VARIATION
MEASURING INSTRUMENTS



DIGITAL
RADIUS GAGES



DIGITAL ARC RADIUS
CALIPERS



DIGITAL RADIUS
CALIPERS

9 KEYWAY MEASUREMENT

PAGE 67-68



KEYWAY SYMMETRY
GAGES



KEYWAY SYMMETRY
DIGITAL CALIPERS



KEYWAY DEPTH
GAGES

10 CHAMFER MEASUREMENT

PAGE 69-70



DIGITAL CHAMFER
GAGES



DIGITAL CHAMFER
GAGES

PRODUCT INDEX

11 INDICATORS, LINEAR GAGES, DIAL INDICATOR STANDS PAGE 71-89



DIAL TEST INDICATORS



INDICATORS



LINEAR GAGES AND DISPLAY UNITS



MAGNETIC STANDS



DIAL INDICATOR STANDS (NON-MAGNETIC)



DIAL INDICATOR STANDS

12 INDICATING MEASURING INSTRUMENTS PAGE 90-97



INTERNAL CALIPER GAGES



EXTERNAL CALIPER GAGES



THICKNESS GAGES

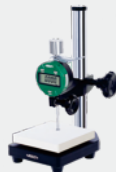

RUBBER THICKNESS GAGES



TUBE THICKNESS GAGES



SNAP GAGES



STEP AND GAP GAGES



MINI DIGITAL HEIGHT GAGES



HEIGHT GAGES

13 STANDARDS AND GAGE BLOCKS PAGE 98-106



GAGE BLOCKS



PIN GAGES



SETTING RINGS



MEASURING BALLS



PLAIN PLUG GAGES



THREADED HOLE LOCATION GAGES



THREAD RING GAGES



THREAD PLUG GAGES

14 ANGLE, STRAIGHTNESS, FLATNESS MEASUREMENT PAGE 107-114



PROTRACTORS



GRANITE SQUARES



PERPENDICULARITY TESTERS



SQUARES



STRAIGHT EDGES



STRAIGHT EDGES



OPTICAL FLATS

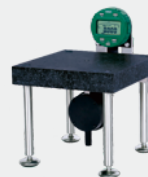

FLATNESS MEASUREMENT STANDS

16 SIMPLE MEASURING TOOLS PAGE 120-138



FEELER GAGES



PITCH GAGES



RADIUS GAGES



TAPER SLOT GAGES



TAPER BORE GAGES



WELDING GAGES



INSIDE/OUTSIDE CALIPERS



MEASURING WHEELS

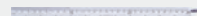

STEEL RULES



COMBINATION SQUARES



T-BEVELS



SCRIBING CALIPERS



PRECISION SCREWDRIVER SETS



MEASURING TOOL SETS

PRODUCT INDEX

15 CONCENTRICITY AND RUNOUT TESTERS PAGE 115-119



CONCENTRICITY GAGES

BENCH CENTERS

17 SET-UP TOOLS PAGE 139-143

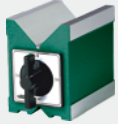

V-BLOCKS



PERMANENT MAGNETIC CHUCKS



PARALLEL SETS



PARALLEL/SQUARE SETS



ANGLE PLATE SETS



SINE BARS



PRECISION VISES



STAGES

20 PAGE 157-162



LINEAR SCALES



SCALES



AIR GAGES AND DISPLAYS



LASER SCAN MICROMETERS

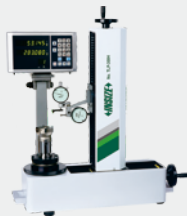

TOOL PRESETTERS

21 FLAW DETECTORS PAGE 163-165



DIGITAL ULTRASONIC FLAW DETECTORS



PORTABLE MAGNETIC POWDER FLAW DETECTORS



UV FLAW DETECTION LIGHTS

18 ON-MACHINE MEASUREMENT PAGE 144-148



CENTERING INDICATORS



EDGE FINDERS



3D TESTERS



EDGE FINDERS FOR EDM



TRIGGER-TYPE 3D PROBES



INFRARED TRANSMISSION PROBES FOR CNC MACHINE TOOLS



ZERO SETTERS

19 LEVELS PAGE 149-156



LEVELS



CROSS-LINE LASER LEVELS



SELF-LEVELING ROTARY LASERS

22 CMM PAGE 166-172



CMM

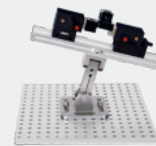

JIG SETS FOR CMM

23 PROFILE PROJECTORS, QUICK MEASUREMENT SYSTEMS, VISION MEASURING SYSTEMS PAGE 173-179



PROFILE PROJECTORS



QUICK MEASUREMENT SYSTEMS



VISION MEASURING SYSTEMS

PRODUCT INDEX

24 MICROSCOPES, MAGNIFIERS

PAGE 180-200



TOOLMAKER MICROSCOPES



DIGITAL MICROSCOPES



MICROSCOPES



MAGNIFIERS



TELESCOPING INSPECTION MIRRORS

25 VIDEOSCOPIES

PAGE 201-204



VIDEOSCOPIES

26 COATING INSPECTION

PAGE 205-214



COATING THICKNESS GAGES



SURFACE PROFILE GAGES



WET FILM GAGES



HOLIDAY DETECTORS



GLOSS METERS



COLORIMETERS



PENCIL HARDNESS TESTERS



CROSS CUT ADHESION TESTERS



DIGITAL ADHESION TESTERS



ROTATIONAL ABRASION TESTERS



PAINT FILM FLEXIBILITY TESTERS



IMPACT TESTERS

27 PORTABLE INSTRUMENTS

PAGE 215-229



ULTRASONIC THICKNESS GAGES



TACHOMETERS



VIBRATION PENS



LASER DISTANCE METERS



PORTABLE CONDUCTIVITY/TDS METERS



PORTABLE pH METERS



REFRACTOMETERS



DIGITAL STOPWATCHES



STROKE COUNTERS



DIGITAL MOISTURE METERS



DIFFERENTIAL PRESSURE MANOMETERS



ANEMOMETERS



BOURDON TUBE PRESSURE GAGES



SOUND LEVEL METERS



LIGHT METERS



GAS DETECTORS



TESLAMETERS



LASER BELT TENSION METERS



DIGITAL GLASS THICKNESS METERS



LIGHT TRANSMITTANCE METERS

PRODUCT INDEX

28 ELECTRONIC TESTING PAGE 230-235



DC RESISTANCE TESTERS



DC POWER SUPPLIES



DIGITAL MULTIMETERS



DIGITAL AC/DC CLAMP METERS



VOLTAGE TESTERS

30 PROFILE AND ROUGHNESS TESTERS PAGE 242-250



SURFACE PROFILE MEASURING MACHINES

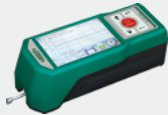

ROUGHNESS TESTERS



SURFACE ROUGHNESS SPECIMENS

33 TESTING MACHINES, FORCE GAGES PAGE 275-279

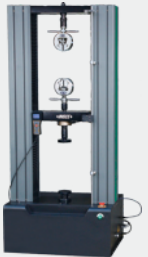

UNIVERSAL TESTING MACHINES



DIGITAL SPRING TESTERS



FORCE GAGES



DIAL TENSION GAGES

35 SCALES PAGE 288-298



SCALES



WEIGHT SETS

29 TEMPERATURE AND HUMIDITY MEASUREMENT PAGE 236-241



INFRARED THERMAL IMAGING CAMERAS



INFRARED THERMOMETERS



THERMOHYGRO METERS

31 HARDNESS TESTERS PAGE 251-271



HARDNESS TESTERS

32 METALLOGRAPHY PREPARATION PAGE 272-274



CUTTING MACHINES



GRINDERS AND POLISHERS

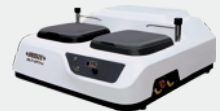

MOUNTING PRESSES

34 TORQUE TESTERS TORQUE WRENCHES PAGE 280-287



TORQUE TESTERS



TORQUE SCREWDRIVERS



TORQUE WRENCHES

36 SALT SPRAY TESTERS, TEMPERATURE AND HUMIDITY CHAMBERS PAGE 299-301



SALT SPRAY TESTERS



TEMPERATURE AND HUMIDITY CHAMBERS



Data Transmission Systems
Page 2-3



Data Output Cables
Page 4

DATA TRANSMISSION SYSTEM

- Through wireless transmission, the readings of measuring tools can be transmitted to computers or mobile phones
- Wireless zigbee protocol, conforming to IEEE802, 2.4GHz band
- Transmission distance is 15 meter (under the condition of no obstruction and no electromagnetic interference)

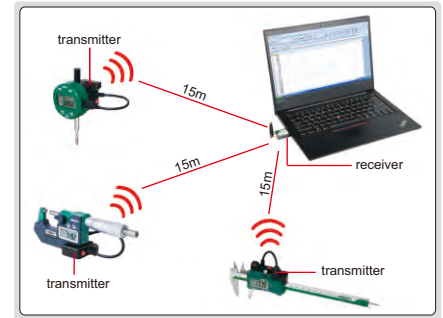

Transmitter

- Connecting to digital measuring tools such as calipers, micrometers and indicators
- CR2032 battery





Code	Description	Transmitter	Connecting with measuring tool	Transmit data
7315-21	transmitter for digital calipers			<ul style="list-style-type: none"> Press the transmit button on the plug of cable, can also press the transmit button of the transmitter Data is transmitted once, the signal light of the transmitter flashes once
7315-22	transmitter for large digital calipers			<ul style="list-style-type: none"> Press the button of the transmitter Data is transmitted once, the signal light of the transmitter flashes once
7315-31	transmitter for digital micrometers		 	<ul style="list-style-type: none"> Press the "data" button of digital micrometer Data is transmitted once, the signal light on the digital micrometer flashes once
7315-50M	transmitter for digital indicators			<ul style="list-style-type: none"> Press the transmit button of the transmitter Data is transmitted once, the signal light of the transmitter flashes once
7315-51	transmitter for digital indicators		 	<ul style="list-style-type: none"> Press the "DATA" button of digital indicator, can also press the foot switch (code 7304-7, optional) Data is transmitted once, the signal light on digital indicator flashes once

To be continued

Continued from previous page



Receiver (keyboard signal)

- For computers and mobile phones
- Recognized as HID keyboard device, the transmitted data is recognized by computers or mobile phones as keyboard input data and press enter key, such as 12.34✓.
- No need to install drivers and softwares
- Data can be transmitted to excel, word, txt etc.
- For any softwares which can receive keyboard signal

Code	Product	Description	Remark
7315-3	USB port 	single channel receiver	connected with 1 transmitter only
7315-6	USB port 	multichannel receiver	connected with 6 transmitters, each channel has status indicator
7315-7	type-C port 		
7315-8	micro USB port 		
7315-9	lightning port 		

Receiver (text format, virtual com port)

- For computers with windows system
- Text format virtual com port, converted to keyboard format with supplied software
- Supplied with EXCEL directional input software
- Measurement data can be transmitted to excel, word, txt etc. and any software which receives keyboard signal

Code	Product	Description	Remark
7315-2	antenna  USB port 	multichannel receiver	connected with maximum 16 transmitters, each of them has unique identification code

EXCEL directional input software

- Supplied with 7315-2 receiver
- The readings of measuring tools can be transmitted to the designated area of excel, which facilitates data management and improves efficiency

Excel directional input software (included in 7315-2), application example 1

Set the display area of caliper at B4-B9, the readings of caliper are displayed at B4, B5...B9.
Set the display area of micrometer at C4-C9, the readings of micrometer are displayed at C4, C5... C9.
Set the display area of height gage at D4-D9, the readings of height gage are displayed at D4, D5... D9.

	A	B	C	D
1	Project	Length	Width	Height
2	Dimension and Tolerance	50±0.05	24±0.01	10+0.05/-0.06
3	Measuring tool	Caliper	Micrometer	Height gage
4	1	50.02	24.004	9.98
5	2	50.01	24.010	10.01
6	3	49.99	23.990	10.02
7	4	50.00	23.996	9.99
8	5	50.04	24.000	10.01
9	6	Channel 1	Channel 2	Channel 3

serial of workpieces the next data display area is indicated in green

Excel directional input software (included in 7315-2), application example 2

Set the display area of micrometer at B4-C9, data input is from the left to the right, the readings of micrometer are displayed at B4, C4, B5, C5... B9, C9.
Set the display area of caliper at D4-D9, the readings of caliper are displayed at D4, D5... D9.
Set the display area of depth gage at E4-E9, the readings of depth gage are displayed at E4, E5... E9.

	A	B	C	D	E
1	Project	External diameter1	External diameter2	Length	Depth
2	Dimension and Tolerance	Φ23+0.01/-0.02	Φ21+0.01/-0.02	50±0.04	28±0.05
3	Measuring tool	Micrometer	Micrometer	Caliper	Depth gage
4	1	23.010	21.008	49.98	28.01
5	2	23.010	21.000	49.98	27.98
6	3	22.999	21.000	50	28
7	4	23.007	20.998	50	28
8	5	23.000	20.985	50.01	28.01
9	6	23.008	Channel 1	Channel 2	Channel 3

serial of workpieces the next data display area is indicated in green

DATA OUTPUT CABLES (KEYBOARD FORMAT)

- Recognized as HID keyboard device by computer, no need to install drivers and softwares
- Data can be transmitted to Excel, Word, txt and other files (press transmit button, which is recognized by the computer as keyboard input data and press enter key, such as 12.34 ✓)
- For any softwares which can receive keyboard signal
- Optional accessory: foot switch (code: **7304-2**), hub (code: **7324-HUB4**, **7324-HUB7**), extension cables (code: **7325-ADD5**, **7325-ADD10**)

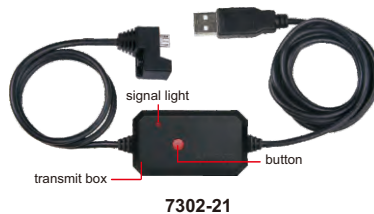

7302-21

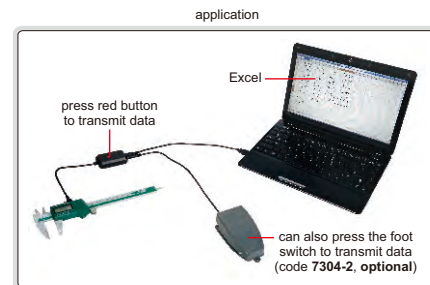

Code	Description	Plug	Connecting with measuring tool	Transmit data
7302-21	cable for digital calipers (length 3m)			<ul style="list-style-type: none"> ▪ Press the button on the plug of cable, can also press the button of the transmit box, or press the foot switch ▪ Data is transmitted once, the signal light of the transmit box flashes once
7302-22	cable for large digital calipers (length 2.5m)			<ul style="list-style-type: none"> ▪ Press the button of the transmit box, or press the foot switch ▪ Data is transmitted once, the signal light of the transmit box flashes once
7302-30	cable for digital micrometers (length 2.5m)		 for 3102, 3128, 3565 series digital micrometers	<ul style="list-style-type: none"> ▪ Press the "data" button of digital micrometer, can also press the button of the transmit box, or press the foot switch ▪ Data is transmitted once, the signal light of the transmit box flashes once, at the same time, the signal light on the digital micrometer flashes once
7302-31	cable for digital micrometers (length 2.5m)		 for 3102, 3128, 3565 series digital micrometers	<ul style="list-style-type: none"> ▪ Press the "data" button of digital micrometer, can also press the button of the transmit box, or press the foot switch ▪ Data is transmitted once, the signal light of the transmit box flashes once, at the same time, the signal light on the digital micrometer flashes once
7302-40M	cable for digital indicators (length 2.5m)		 for 2108, 2138, 2139 series digital indicators	<ul style="list-style-type: none"> ▪ Press the "DATA" button of digital indicator, can also press the button of the transmit box, or press the foot switch ▪ Data is transmitted once, the signal light of the transmit box flashes once, at the same time, the signal light on digital indicator flashes once <p>Note: long press button to zero the digital indicators</p>
			 for other digital indicators	<ul style="list-style-type: none"> ▪ Press the button of the transmit box, or press the foot switch ▪ Data is transmitted once, the signal light of the transmit box flashes once <p>Note: long press button to zero the digital indicators</p>
7302-50M	cable for digital gages (length 2.5m)			<ul style="list-style-type: none"> ▪ Press the button of the transmit box, or press the foot switch ▪ Data is transmitted once, the signal light of the transmit box flashes once



Digital Calipers
Page 6-9



Dial Calipers
Page 9



Vernier Calipers
Page 9-11

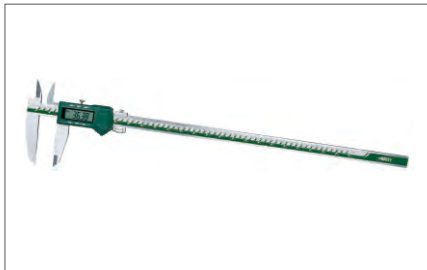

Large Digital Calipers
Page 11

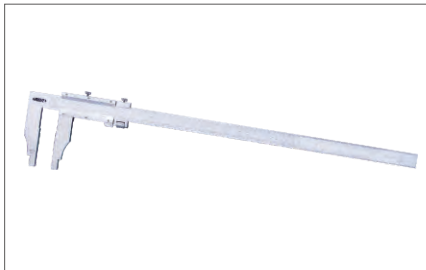

Large Vernier Calipers
Page 11-12



Accessory Sets For Digital Calipers
Page 12



Depth Base Attachments
Page 13



Special Purpose Calipers
Page 13-23

DIGITAL CALIPERS



ATTENTION: THE WORKING LIFE OF A BATTERY IS ABOUT 3-5 MONTHS

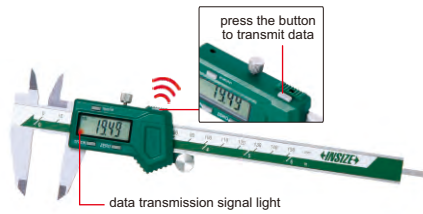
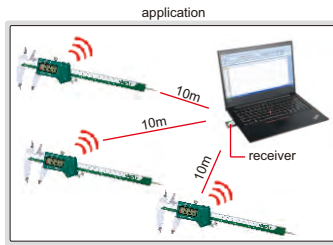

1113-150

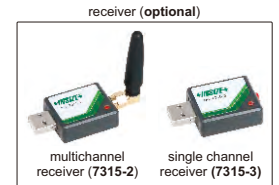

- Non waterproof
- Built-in wireless data transmission module, Zigbee signal
- Transmission distance is 10 meter (under the condition of no obstruction and no electromagnetic interference)
- Resolution: 0.01mm/0.0005"
- Buttons: on/off, zero, mm/inch, data transmission
- Automatic power off, move the digital unit to turn on power
- Battery CR2032
- Made of stainless steel
- Optional accessory: receiver (code 7315-2/3/6/7/8/9)

Code	Range	Accuracy	L	a	b	c	d
1113-150*	0-150mm/0-6"	±0.03mm	236mm	21mm	16mm	16mm	40mm
1113-200*	0-200mm/0-8"	±0.03mm	286mm	24mm	19mm	16mm	50mm
1113-300*	0-300mm/0-12"	±0.03mm	400mm	25mm	20.5mm	16mm	60mm

*Supplied with manufacturer inspection certificate

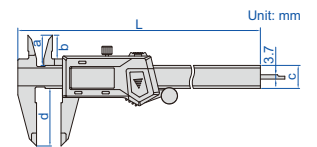

IP67 WATERPROOF DIGITAL CALIPERS



ATTENTION: NO DATA OUTPUT

IP67 WATERPROOF

- IP67 dust/waterproof
- Resolution: 0.01mm/0.0005"
- Button function: zero, on/off, mm/inch
- Battery CR2032
- Automatic power off
- Meet DIN862
- Made of stainless steel



1115-150

POPULAR MODEL

Code	Range	Accuracy	L	a	b	c	d
1115-150*	0-150mm/0-6"	±0.03mm	235mm	20mm	15mm	16mm	40mm
1115-200*	0-200mm/0-8"	±0.03mm	287mm	24mm	19mm	16mm	50mm
1115-300*	0-300mm/0-12"	±0.03mm	388mm	26mm	21mm	16mm	60mm

*Supplied with manufacturer inspection certificate

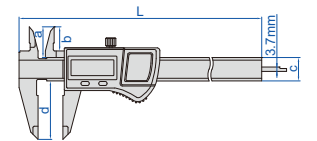

DIGITAL CALIPERS (ABSOLUTE SYSTEM)



DATA OUTPUT

- Non waterproof
- Absolute system, low power consumption, long battery life
- Resolution: 0.01mm/0.0005"
- Buttons: on/off, mm/inch, ORIGIN, ZERO/ABS
- Automatic power off, move the digital unit to turn on power
- Battery CR2032, data output
- Meet DIN862
- Made of stainless steel
- Optional accessory: wireless transmitter, code 7315-22 receiver is needed, data output cable (keyboard format), code 7302-22



1103-150

Code	Range	Accuracy	L	a	b	c	d
1103-150*	0-150mm/0-6"	±0.03mm	236mm	21mm	16.5mm	16mm	40mm
1103-200*	0-200mm/0-8"	±0.03mm	286mm	24mm	19.5mm	16mm	50mm
1103-300*	0-300mm/0-12"	±0.03mm	400mm	26mm	21.5mm	16mm	60mm

*Supplied with manufacturer inspection certificate

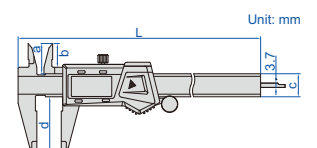

DIGITAL CALIPERS

INSPECTION
CERTIFICATE

ATTENTION: NO
DATA OUTPUT

- Non waterproof
- Zinc alloy housing for digital unit
- Resolution: 0.01mm/0.0005"
- Buttons: zero, on/off, mm/inch
- Automatic power off, move the digital unit to turn on power
- Battery CR2032, meet DIN862
- Made of stainless steel



1114-150A

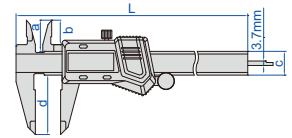

Code	Range	Accuracy	L	a	b	c	d
1114-150A *	0-150mm/0-6"	±0.03mm	236mm	21mm	16mm	16mm	40mm
1114-200A *	0-200mm/0-8"	±0.03mm	286mm	24mm	19mm	16mm	50mm
1114-300A *	0-300mm/0-12"	±0.03mm	400mm	25mm	20.5mm	17mm	60mm

* Supplied with manufacturer inspection certificate

DIGITAL CALIPERS (STANDARD TYPE)

INSPECTION
CERTIFICATE

DATA
OUTPUT

- Non waterproof
- Resolution: 0.01mm/0.0005"
- Buttons: on/off, zero, mm/inch
- Automatic power off, move the digital unit to turn on power
- Battery CR2032
- Data output, meet DIN862
- Made of stainless steel
- Optional accessory: data output cable
(code 7315-21 receiver is needed, 7302-21)



1108-150

POPULAR
MODEL

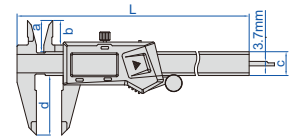

Code	Range	Accuracy	L	a	b	c	d
1108-150 *	0-150mm/0-6"	±0.02mm	236mm	21mm	16mm	16mm	40mm
1108-200 *	0-200mm/0-8"	±0.03mm	286mm	24mm	19mm	16mm	50mm
1108-300 *	0-300mm/0-12"	±0.03mm	400mm	25mm	20.5mm	16mm	60mm

* Supplied with manufacturer inspection certificate

DIGITAL CALIPERS (BASIC TYPE)

ATTENTION: NO
DATA OUTPUT

- Non waterproof
- Resolution: 0.01mm/0.0005"
- Buttons: zero, on/off, mm/inch
- Battery LR44
- Meet DIN862
- Made of stainless steel



1112-150

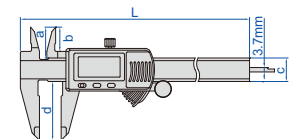

Code	Range	Accuracy	L	a	b	c	d
1112-150	0-150mm/0-6"	±0.03mm	236mm	21mm	16mm	16mm	40mm
1112-200	0-200mm/0-8"	±0.03mm	286mm	24mm	19mm	16mm	50mm
1112-300	0-300mm/0-12"	±0.03mm	400mm	25mm	20.5mm	17mm	60mm

HEAVY DUTY 300mm DIGITAL CALIPER

INSPECTION
CERTIFICATE

DATA
OUTPUT

- Non waterproof
- Resolution: 0.01mm/0.0005"
- Buttons: on/off, zero, mm/inch
- Automatic power off, move the digital unit to turn on power
- Battery CR2032
- Data output
- Meet DIN862
- Made of stainless steel
- Optional accessory: data output cable
(code 7315-22 receiver is needed, 7302-22)



1196-300

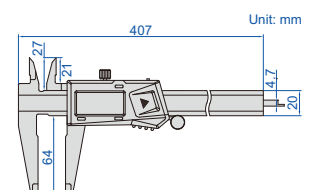

Code	Range	Accuracy
1196-300 *	0-300mm/0-12"	±0.03mm

* Supplied with manufacturer inspection certificate

DIGITAL CALIPER WITH ROUND DEPTH BAR



DATA OUTPUT



1119-150



- Non waterproof
- Resolution: 0.01mm/0.0005"
- Buttons: on/off, zero, mm/inch
- Automatic power off, move the digital unit to turn on power
- Battery CR2032
- Data output
- Meet DIN862
- Made of stainless steel
- Optional accessory: data output cable (code 7315-21 receiver is needed, 7302-21)

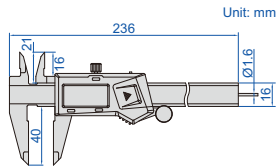

Code	Range	Accuracy
1119-150*	0-150mm/0-6"	$\pm 0.03\text{mm}$

*Supplied with manufacturer inspection certificate

LEFT HAND DIGITAL CALIPER



DATA OUTPUT



1130-150

- Non waterproof
- Designed for left handed users
- Resolution: 0.01mm/0.0005"
- Buttons: on/off, zero, mm/inch
- Automatic power off, move the digital unit to turn on power
- Battery CR2032, data output
- Meet DIN862
- Made of stainless steel
- Optional accessory: data output cable (code 7315-22 receiver is needed, 7302-22)

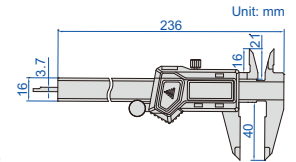

Code	Range	Accuracy
1130-150*	0-150mm/0-6"	$\pm 0.03\text{mm}$

*Supplied with manufacturer inspection certificate

DIGITAL CALIPERS WITH CARBIDE TIPPED JAWS



DATA OUTPUT

- Non waterproof
- Resolution: 0.01mm/0.0005"
- Buttons: on/off, zero, mm/inch
- Automatic power off, move the digital unit to turn on power
- Battery CR2032, data output
- Meet DIN862
- Made of stainless steel
- Optional accessory: data output cable (code 7315-21 receiver is needed, 7302-21)



1110-150B

Carbide tipped lower jaws

Code	Range	Accuracy	L	a	b	d
1110-150B*	0-150mm/0-6"	$\pm 0.03\text{mm}$	236mm	21mm	16mm	40mm
1110-200B*	0-200mm/0-8"	$\pm 0.03\text{mm}$	286mm	24mm	19mm	50mm
1110-300B*	0-300mm/0-12"	$\pm 0.03\text{mm}$	400mm	25mm	20.5mm	60mm

*Supplied with manufacturer inspection certificate

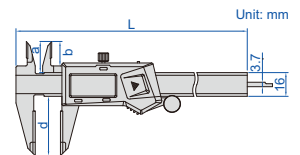

DIGITAL CALIPER

DATA OUTPUT



1170-300

- Non waterproof
- Resolution: 0.01mm/0.0005"
- Buttons: on/off, zero, mm/inch
- Automatic power off, move the digital unit to turn on power
- Battery CR2032
- Data output
- Made of stainless steel
- Optional accessory: data output cable (code 7315-21 receiver is needed, 7302-21)

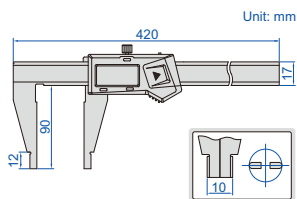

Code	Range	Accuracy
1170-300	0-300mm/0-12"	$\pm 0.06\text{mm}$

DIGITAL CALIPER

DATA OUTPUT



1171-300

- Non waterproof
- Resolution: 0.01mm/0.0005"
- Buttons: on/off, zero, mm/inch
- Automatic power off, move the digital unit to turn on power
- Battery CR2032
- Data output
- Made of stainless steel
- Optional accessory: data output cable (code 7315-21 receiver is needed, 7302-21)

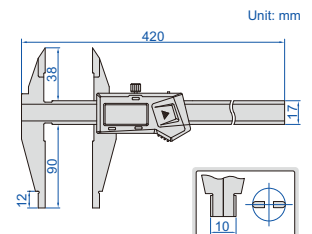

Code	Range	Accuracy
1171-300	0-300mm/0-12"	$\pm 0.06\text{mm}$

MINI DIGITAL CALIPERS

ATTENTION:
NO DATA OUTPUT



1111-100A

- Non waterproof
- Resolution: 0.01mm/0.0005"
- Buttons: zero, mm/inch, on/off
- Automatic power off, move the digital unit to turn on power
- Battery LR44
- Meet DIN862
- Made of stainless steel

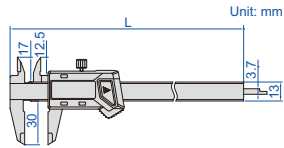

Code	Range	Accuracy	L
1111-75A	0-75mm/0-3"	±0.02mm	144mm
1111-100A	0-100mm/0-4"	±0.02mm	170mm

PLASTIC DIGITAL CALIPER

ATTENTION:
NO DATA OUTPUT



1139-150

- Non waterproof
- Made of hard plastic, non-magnetic and non electric conductive
- Prevent workpieces from scratching by calipers
- Resolution: 0.01mm/0.0005"
- Buttons: on/off, zero, mm/inch
- Battery CR2032, automatic power off

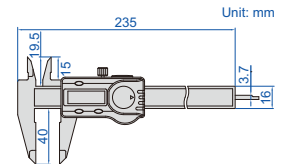

Code	Range	Accuracy
1139-150	0-150mm/0-6"	±0.1mm

DIAL CALIPERS

INSPECTION
CERTIFICATE

SHOCK
PROOF

Dial indicator graduation: 0.02mm

(mm)

Code	Range	Accuracy	L	a	b	c	d	D	t
1312-150A*	0-150mm	±0.03mm	235	21	16.5	16	40	Ø39	6.5
1312-200A*	0-200mm	±0.03mm	288	24	19	16	48	Ø39	6.5
1312-300A*	0-300mm	±0.03mm	410	28	22	20	62	Ø44.5	7.5



1312-150A

Dial indicator graduation: 0.01mm

(mm)

Code	Range	Accuracy	L	a	b	c	d	D	t
1311-150A*	0-150mm	±0.03mm	235	21	16.5	16	40	Ø39	6.5
1311-200A*	0-200mm	±0.03mm	288	24	19	16	48	Ø39	6.5
1311-300A*	0-300mm	±0.03mm	410	28	22	20	62	Ø44.5	7.5

- Shockproof dial indicator
- Made of stainless steel

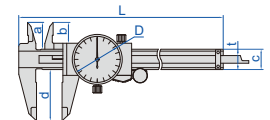

*Supplied with manufacturer inspection certificate

DIAL CALIPERS

SHOCK
PROOF

- Shockproof dial indicator
- Dial indicator graduation: 0.02mm
- Made of stainless steel



1316-500

Code	Range	Accuracy	a	c	d	e	L
1316-500	0-500mm	±0.05mm	18mm	21mm	90mm	20mm	650mm
1316-600	0-600mm	±0.05mm	18mm	21mm	90mm	20mm	750mm
1316-1000	0-1000mm	±0.07mm	24mm	28mm	150mm	20mm	1190mm
1316-1500	0-1500mm	±0.11mm	24mm	28mm	150mm	20mm	1690mm

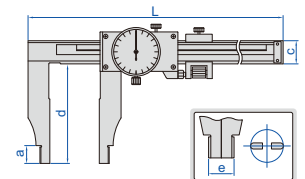

MINI VERNIER CALIPER

- Meet DIN862
- Made of stainless steel
- Satin chrome plated reading surface



1201-1003

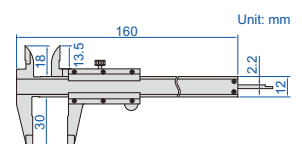

Code	Range	Graduation	Accuracy
1201-1003	0-100mm	0.05mm	±0.05mm

VERNIER CALIPERS

POPULAR MODEL

- Accuracy: $\pm 0.03\text{mm}$
- Graduation: $0.02\text{mm}/0.001''$
- Meet DIN862
- Made of stainless steel
- Satin chrome plated reading surface



1205-1502S

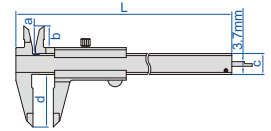

Code	Range	L	a	b	c	d
1205-1502S	0-150mm/0-6"	235mm	20.5mm	15.5mm	16mm	40mm
1205-2002S	0-200mm/0-8"	290mm	23.5mm	19mm	17mm	50mm
1205-3002S	0-300mm/0-12"	414mm	27.5mm	22mm	20mm	64mm

VERNIER CALIPERS WITH THUMB CLAMP

- Meet DIN862
- With thumb clamp
- Made of stainless steel
- Satin chrome plated reading surface



1223-1502

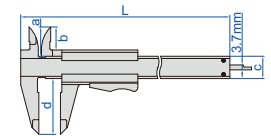

Graduation $0.02\text{mm}/0.001''$

Code	Range	Accuracy	L	a	b	c	d
1223-1502	0-150mm/0-6"	$\pm 0.03\text{mm}$	230mm	20.5mm	16.5mm	16mm	40mm
1223-2002	0-200mm/0-8"	$\pm 0.03\text{mm}$	295mm	23.5mm	19mm	16mm	50mm

VERNIER CALIPERS WITH FINE ADJUSTMENT



1233-130

- Graduation: $0.02\text{mm}/0.001''$
- Accuracy: $\pm 0.03\text{mm}$
- With fine adjustment
- Meet DIN862
- Made of stainless steel
- Satin chrome plated reading surface

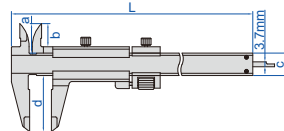

Code	Range	L	a	b	c	d
1233-130	0-130mm/0-5"	230mm	20.5mm	16.5mm	16mm	40mm
1233-180	0-180mm/0-7"	295mm	23.5mm	19mm	16mm	50mm
1233-280	0-280mm/0-11"	410mm	26mm	20mm	20mm	60mm

VERNIER CALIPERS WITH CARBIDE TIPPED JAWS



1238-1502

- Carbide tipped jaws for inside and outside measurements
- Meet DIN862
- Made of stainless steel
- Satin chrome plated reading surface

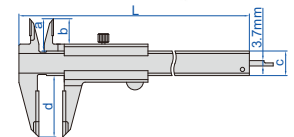

Graduation $0.02\text{mm}/0.001''$

(mm)

Code	Range	Accuracy	L	a	b	c	d
1238-1502	0-150mm/0-6"	$\pm 0.03\text{mm}$	230	21	16.5	16	40
1238-2002	0-200mm/0-8"	$\pm 0.03\text{mm}$	295	24	19	16	50
1238-3002	0-300mm/0-12"	$\pm 0.03\text{mm}$	410	25	20	16	60

VERNIER CALIPER



1217-3001

- With fine adjustment
- Made of stainless steel
- Satin chrome plated reading surface

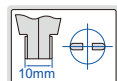
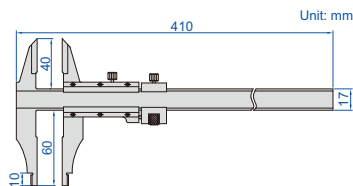

Code	Range	Graduation	Accuracy
1217-3001	0-300mm	0.02mm	$\pm 0.03\text{mm}$

VERNIER CALIPER (ANTI MAGNETIC)

PURE COPPER

ATTENTION: NOT HARDENED



1224-150A

- Suitable for magnetic parts
- Made of pure copper

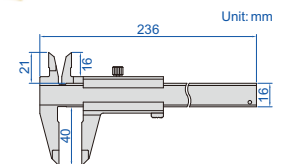

Code	Range	Graduation	Accuracy
1224-150A	0-150mm	0.02mm	$\pm 0.05\text{mm}$

LEFT HAND VERNIER CALIPERS

- Designed for left handed users
- Made of stainless steel
- Satin chrome plated reading surface



1239-1502

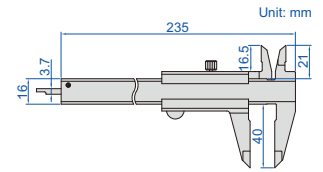

Code	Range	Graduation	Accuracy
1239-1502	0-150mm/0-6"	0.02mm/0.001"	±0.03mm
1239-1501	0-150mm	0.02mm	±0.03mm

DIGITAL CALIPERS

- Non waterproof
- Resolution: 0.01mm/0.0005"
- Button function: on/off, zero, mm/inch, ABS, data preset
- Battery CR2032, data output
- Made of stainless steel



1106-501

DATA OUTPUT

POPULAR MODEL

Code	Range	Accuracy	a	c	d	L	Data output cable (optional)
1106-501	0-500mm/0-20"	±0.05mm	18mm	24mm	100mm	675mm	7315-22 receiver is needed, 7302-22
1106-601	0-600mm/0-24"	±0.05mm	18mm	24mm	100mm	770mm	7315-22 receiver is needed, 7302-22
1106-1002	0-1000mm/0-40"	±0.08mm	24mm	31mm	150mm	1220mm	7315-22 receiver is needed, 7302-22
1106-1502	0-1500mm/0-60"	±0.11mm	24mm	42mm	150mm	1780mm	7315-20B receiver is needed, 7302-SPC1A

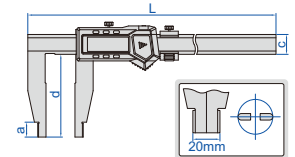

DIGITAL CALIPERS

DATA OUTPUT



1136-501

- Non waterproof
- Resolution: 0.01mm/0.0005"
- Button function: on/off, zero, mm/inch, ABS, data preset
- Battery CR2032, data output
- Made of stainless steel
- Optional accessory: data output cable (code 7315-22 receiver is needed, 7302-22)

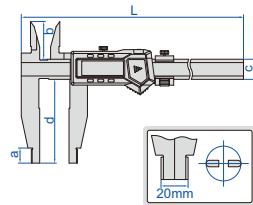

(mm)

Code	Range	Accuracy	a	b	c	d	L
1136-501	0-500mm/0-20"	±0.05mm	18	45	24	100	675
1136-601	0-600mm/0-24"	±0.05mm	18	45	24	100	770
1136-1002	0-1000mm/0-40"	±0.08mm	24	60	31	150	1220

DIGITAL CALIPERS

DATA OUTPUT



1135-601

- Non waterproof
- Resolution: 0.01mm/0.0005"
- Button function: on/off, zero, mm/inch, ABS, data preset
- Battery CR2032, data output
- Made of stainless steel
- Optional accessory: data output cable (code 7315-22 receiver is needed, 7302-22)

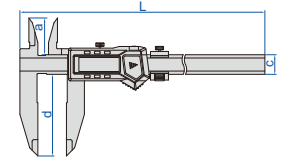

(mm)

Code	Range	Accuracy	a	c	d	L
1135-451	0-450mm/0-18"	±0.05mm	45	24	100	625
1135-601	0-600mm/0-24"	±0.05mm	45	24	100	770
1135-1002	0-1000mm/0-40"	±0.08mm	60	31	150	1220

LONG JAW VERNIER CALIPERS (SEPARATE TYPE)

- With fine adjustment
- Made of stainless steel
- Satin chrome plated reading surface



1215-1032

separate type (with screws)



Graduation 0.02mm/0.001"

Code	Range	Accuracy	a	c	d	e	L
1215-522	0-500mm/0-20"	±0.06mm	18mm	24mm	150mm	20mm	670mm
1215-1032	0-1000mm/0-40"	±0.08mm	24mm	32mm	200mm	20mm	1220mm

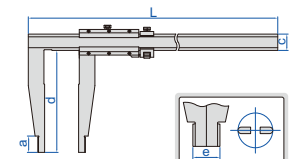

VERNIER CALIPERS (SEPARATE TYPE)

POPULAR MODEL

- Graduation: 0.02mm/0.001"
- With fine adjustment
- Made of stainless steel
- Satin chrome plated reading surface



1214-500

Code	Range	Accuracy	a	c	d	e	L
1214-500	0-500mm/0-20"	±0.05mm	18mm	24mm	100mm	20mm	670mm
1214-600	0-600mm/0-24"	±0.05mm	18mm	24mm	100mm	20mm	770mm
1214-1000	0-1000mm/0-40"	±0.08mm	24mm	32mm	140mm	20mm	1216mm
1214-1500	0-1500mm/0-60"	±0.12mm	24mm	42mm	200mm	20mm	1830mm
1214-2000	0-2000mm/0-80"	±0.14mm	24mm	42mm	200mm	20mm	2320mm

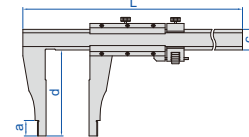

separate type (with screws)

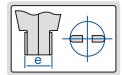

ACCESSORY SET FOR DIGITAL CALIPERS CODE 6144



6144

- Suitable for 0-150mm/0-6" and 0-200mm/0-8" digital calipers (thickness of lower jaws ≤ 3.7mm)

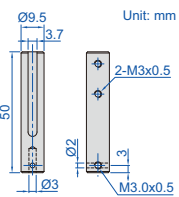

Unit: mm

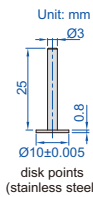

Unit: mm

disk points (stainless steel)

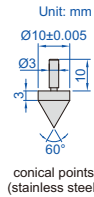

Unit: mm

conical points (stainless steel)

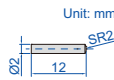

Unit: mm

spherical/flat points (stainless steel)

Code

6144

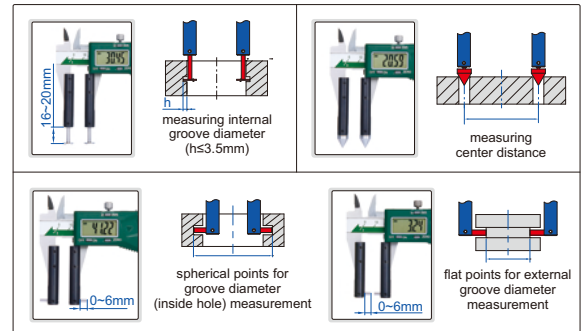

ACCESSORY SET FOR LARGE DIGITAL CALIPERS CODE 6145-500



- Suitable for 0-500mm/0-20" and 0-600mm/0-24" digital calipers (thickness of lower jaws ≤ 5.6mm)

Code
6145-500

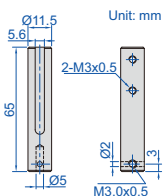

Unit: mm

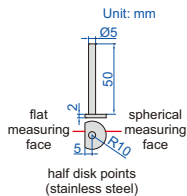

Unit: mm

flat measuring face
spherical measuring face
half disk points (stainless steel)

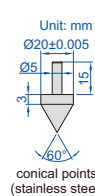

Unit: mm

conical points (stainless steel)

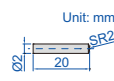

Unit: mm

spherical/flat points (stainless steel)

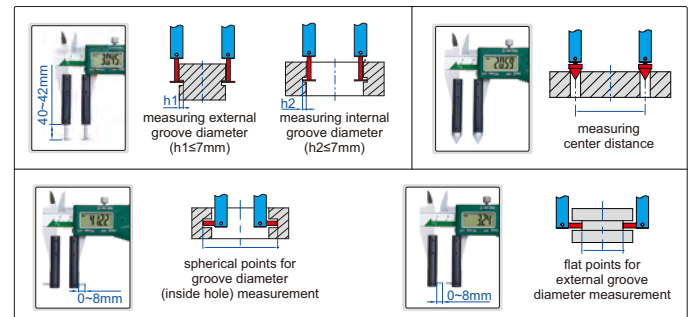

DEPTH BASE ATTACHMENTS

- To increase the stability of depth measurement
- Suitable for digital calipers and dial calipers
- Made of stainless steel
- Application: suitable for calipers with beam width (w) 16mm

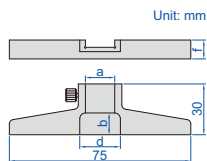

6140



6140-16B

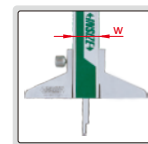

Code	a	b	d	f	Type
6140	16.5mm	9mm	18mm	6mm	narrow base (f=6)
6140-16B	16mm	12.5mm	24.5mm	11mm	wide base (f=11), high stability

UNIVERSAL CALIPER

- Non waterproof
- Buttons: on/off, set, mm/inch, ABS, preset (+, -)
- Automatic power off, move the digital unit to turn on power
- Battery CR2032, data output
- Made of stainless steel
- Optional accessory: data output cable (code 7315-22 receiver is needed, 7302-22)



1125-600

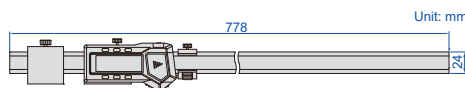

DATA OUTPUT

VIDEO

working with stands



working with measuring jaws

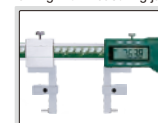

Code	Range*	Resolution	Accuracy
1125-600	0-600mm/0-24"	0.01mm/0.0005"	±0.05mm

*The range changes according to different points

Half disk points (included)

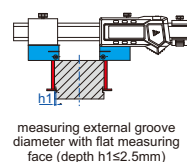
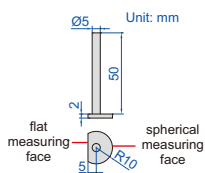

measuring external groove diameter with flat measuring face (depth $h_1 \leq 2.5\text{mm}$)

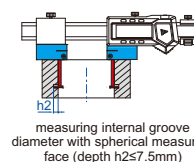

measuring internal groove diameter with spherical measuring face (depth $h_2 \leq 7.5\text{mm}$)

Round shoulder points (optional)

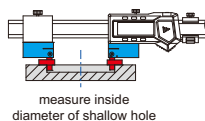
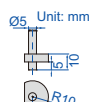

measure inside diameter of shallow hole

Conical points (optional)

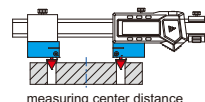
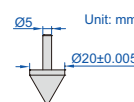

measuring center distance

Code
1125-T102

Code
1125-T101

Spherical points (included)

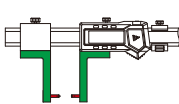
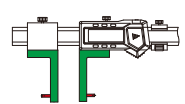
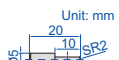

Flat shoulder points (optional)

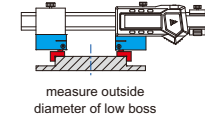
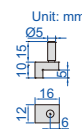

measure outside diameter of low boss

Code
1125-T103

Stands (included)

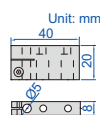

Depth stop (included)

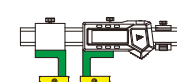
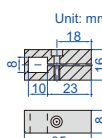

Measuring jaws (included)

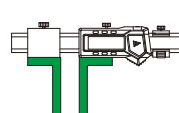
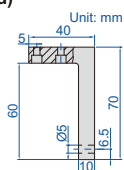

Point sleeve (optional)

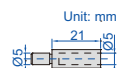

Code
1125-T104

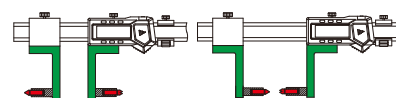

working with multifunctional points, ball points and screw thread points

Multifunctional points 7392* (optional)



Ball points 7391* (optional)



Screw thread points 7381*, 7321* (optional)



*It is necessary to use point sleeve (code 1125-T104) for these points

DIGITAL CALIPER WITH INTERCHANGEABLE POINTS CODE 1526-200



DATA
OUTPUT



1526-200

short spherical points (included)



long spherical/flat points (included)



spherical blade points (included)

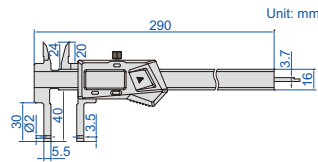
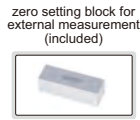
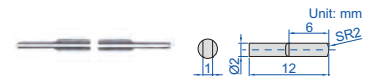

measure internal and external grooves

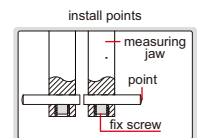
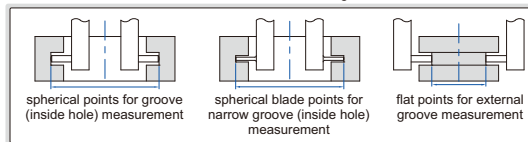

- Non waterproof
- Supplied with 3 pairs of points and zero setting block for external measurement
- Resolution: 0.01mm/0.0005"
- Buttons: on/off, set, mm/inch, preset (+, -)
- Automatic power off, move the digital unit to turn on power
- Battery CR2032
- Data output
- Made of stainless steel
- Optional accessory: points, data output cable (code 7315-21 receiver is needed, 7302-21)

Point	Range	Accuracy	Application
short spherical points	12-212mm/0.5-8.5"(internal)	±0.03mm	for grooves inside small hole
long spherical/flat points	24-224mm/1-8.8"(internal) 0-187mm/0-7.5"(external)	±0.03mm	spherical points for grooves inside hole flat points for external grooves
spherical blade points	24-224mm/1-8.8"(internal) 0-187mm/0-7.5"(external)	±0.03mm	for narrow grooves inside hole

Depth stop (optional)

Code
6143



6143

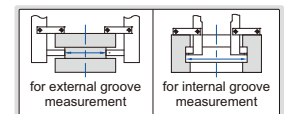
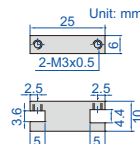

Point sleeve (optional)

Code
1526-T101



1526-T101

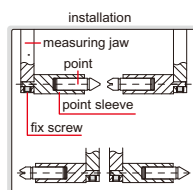
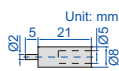

Code
1526-T101

Ball points (optional)



7391-T5



- * It is necessary to use point sleeve (code 1526-T101) for these points
- ** Range of 1526-200 after installing the points and point sleeve

Code	Ball dia. (D)	Range **
7391-T3 *	SØ2.0mm	75-275mm/3.0-10.8" (internal) 0-146mm/0-5.7" (external)
7391-T4 *	SØ2.5mm	76-276mm/3.0-10.8" (internal) 0-145mm/0-5.7" (external)
7391-T5 *	SØ3.0mm	77-277mm/3.0-10.9" (internal) 0-144mm/0-5.6" (external)
7391-T6 *	SØ3.5mm	78-278mm/3.1-10.9" (internal) 0-143mm/0-5.6" (external)
7391-T7 *	SØ4.0mm	79-279mm/3.1-10.9" (internal) 0-142mm/0-5.6" (external)
7391-T8 *	SØ4.5mm	80-280mm/3.2-11.0" (internal) 0-141mm/0-5.5" (external)
7391-T9 *	SØ5.0mm	81-281mm/3.2-11.0" (internal) 0-140mm/0-5.5" (external)
7391-T10 *	SØ6.0mm	83-283mm/3.3-11.1" (internal) 0-138mm/0-5.4" (external)

To be continued

Continued from previous page

Multifunctional points (optional)

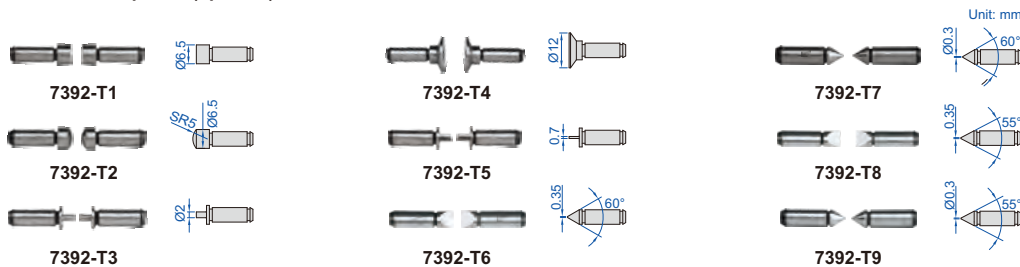

Code	Type
7392-T1*	flat
7392-T2*	spherical
7392-T3*	spline

Code	Type
7392-T4*	disk
7392-T5*	blade
7392-T6*	knife-edge

Code	Type
7392-T7*	point
7392-T8*	knife-edge
7392-T9*	point

Range**
66-266mm/2.6-10.5" (internal)
0-155mm/0-6.1" (external)
**Range of 1526-200 after installing the points and point sleeve

*It is necessary to use point sleeve (code 1526-T101) for these points

Screw thread points (optional)



Internal thread (60° thread angle)

Code	Pitch
7321-T11*	0.4-0.5mm/64-48TPI
7321-T12*	0.6-0.9mm/44-28TPI
7321-T13*	1-1.75mm/24-14TPI
7321-T14*	2-3mm/13-9TPI
7321-T15*	3.5-5mm/8-5TPI
7321-T16*	5.5-7mm/4.5-3.5TPI
7321-T15*	6 pairs/set, including all above points

External thread (60° thread angle)

Code	Pitch
7381-T11*	0.4-0.5mm/64-48TPI
7381-T12*	0.6-0.9mm/44-28TPI
7381-T13*	1-1.75mm/24-14TPI
7381-T14*	2-3mm/13-9TPI
7381-T15*	3.5-5mm/8-5TPI
7381-T16*	5.5-7mm/4.5-3.5TPI
7381-TS*	6 pairs/set, including all above points

Range**
66-266mm/2.6-10.5" (internal)
0-155mm/0-6.1" (external)
**Range of 1526-200 after installing the points and point sleeve

*It is necessary to use point sleeve (code 1526-T101) for these points

DIGITAL CALIPER WITH INTERCHANGEABLE POINTS

VARIOUS POINTS ARE AVAILABLE

DATA OUTPUT



- Non waterproof
- Supplied with 4 pairs of points and zero setting block for external measurement
- Resolution: 0.01mm/0.0005"
- Buttons: on/off, set, mm/inch, preset (+, -)
- Automatic power off, move the digital unit to turn on power
- Battery CR2032
- Data output
- Made of stainless steel
- Optional accessory: points, depth stop (code 6143), data output cable (code 7315-21 receiver is needed, 7302-21)

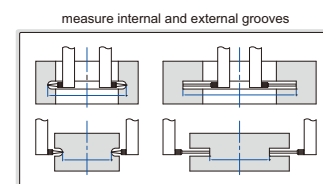
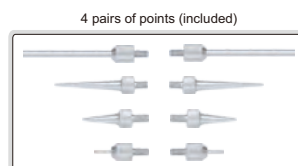
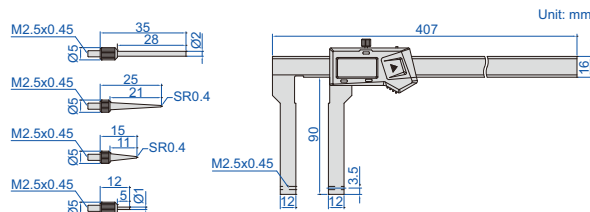

Code	Range*	Accuracy
1530-300	0-300mm/0-12"	± 0.06 mm

*For different points, the measuring range changes accordingly

DIGITAL CALIPER WITH INTERCHANGEABLE POINTS CODE 1124-300A



DATA
OUTPUT

short spherical/flat points (included)



long spherical/flat points (included)



short spherical blade points (included)

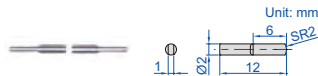

long spherical blade points (included)



1124-300A

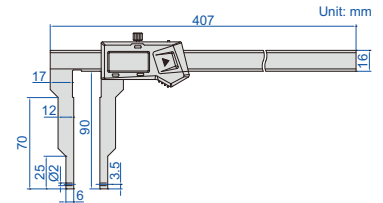

depth stop 6143
(optional)



preset buttons



zero setting block for
external measurement
(included)



install points

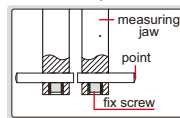

measure internal and external grooves

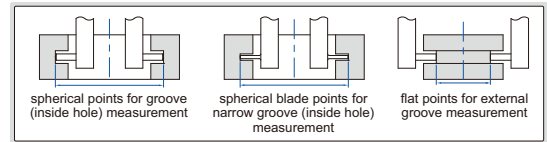

- Non waterproof
- Supplied with 4 pairs of points and zero setting block for external measurement
- Resolution: 0.01mm/0.0005"
- Buttons: on/off, set, mm/inch, preset (+, -)
- Automatic power off, move the digital unit to turn on power
- Battery CR2032
- Data output
- Made of stainless steel
- Optional accessory: points (code 1526-T101, 7392, 7391, 7381, 7321), depth stop (code 6143), data output cable (code 7315-21 receiver is needed, 7302-21)

Point	Range	Accuracy	Application
short spherical/flat points	24-324mm/1-12.7" (internal) 0-288mm/0-11.3" (external)	±0.04mm	spherical points for grooves inside hole (small hole) flat points for external grooves
long spherical/flat points	40-340mm/1.5-13.3" (internal) 0-272mm/0-10.7" (external)	±0.04mm	spherical points for grooves inside hole (large hole) flat points for external grooves
short spherical blade points	24-324mm/1-12.7" (internal) 0-288mm/0-11.3" (external)	±0.04mm	for narrow grooves inside hole (small hole)
long spherical blade points	40-340mm/1.5-13.3" (internal) 0-272mm/0-10.7" (external)	±0.04mm	for narrow grooves inside hole (large hole)

Multifunctional points 7392* (optional)



Ball points 7391* (optional)



Screw thread points 7381*, 7321* (optional)

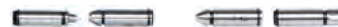

* It is necessary to use point sleeve (code 1526-T101) for these points

DIGITAL INSIDE GROOVE CALIPER

DATA
OUTPUT



1520-150

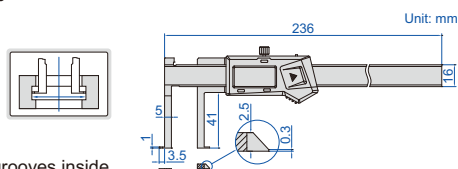

- Non waterproof
- Measure diameter of grooves inside small bores
- Resolution: 0.01mm/0.0005"
- Buttons: on/off, set, mm/inch, preset (+, -)
- Battery CR2032, data output
- Made of stainless steel
- Optional accessory: depth stop (code 6143), data output cable (code 7315-21 receiver is needed, 7302-21)



depth stop 6143
(optional)



Code	Range	Accuracy
1520-150	11-150mm/0.43-6"	±0.04mm

DIGITAL INSIDE POINT CALIPER

DATA
OUTPUT



1121-150A

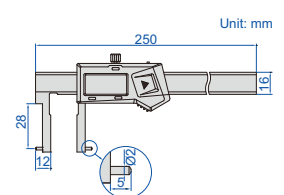

- Non waterproof
- Measure groove diameter
- Resolution: 0.01mm/0.0005"
- Buttons: on/off, set, mm/inch, preset (+, -)
- Automatic power off, move the digital unit to turn on power
- Battery CR2032, data output
- Made of stainless steel
- Optional accessory: depth stop (code 6143), data output cable (code 7315-21 receiver is needed, 7302-21)



depth stop 6143
(optional)



Code	Range	Accuracy
1121-150A	24-150mm/0.94-6"	±0.04mm

DIGITAL INSIDE GROOVE CALIPERS

DATA OUTPUT

- Non waterproof
- Measure groove diameter
- Resolution: 0.01mm/0.0005"
- Buttons: on/off, set, mm/inch, preset (+,-)
- Battery CR2032, data output
- Made of stainless steel
- Optional accessory: depth stop (code 6143), data output cable (code 7315-21 receiver is needed, 7302-21)



1120-150A

Code	Range	Accuracy	L	b	d	e
1120-150A	22-150mm/0.87-6"	±0.04mm	250mm	11mm	30mm	1mm
1120-200A	25-200mm/0.98-8"	±0.04mm	310mm	12.5mm	40mm	1mm
1120-300A	30-300mm/1.18-12"	±0.05mm	410mm	15mm	50mm	1.5mm

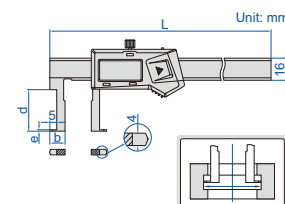
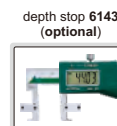

INSIDE GROOVE VERNIER CALIPER

- Graduation: 0.02mm
- Measure diameter of grooves inside bores
- Made of stainless steel
- Satin chrome plated reading surface



1262-150A

Code	Range	Accuracy
1262-150A	18-150mm	±0.04mm

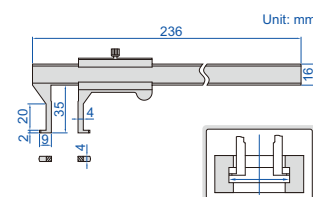

DIGITAL INSIDE GROOVE CALIPERS

DATA OUTPUT

- Non waterproof
- Measure diameter of grooves inside bores
- Resolution: 0.01mm/0.0005"
- Buttons: on/off, set, mm/inch, preset (+,-)
- Battery CR2032, data output
- Made of stainless steel
- Optional accessory: depth stop (code 6143), data output cable (code 7315-21 receiver is needed, 7302-21)



1176-150

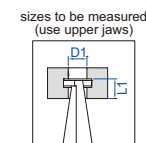
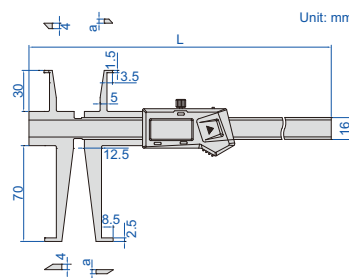

sizes to be measured (use upper jaws)		(mm)
D1	L1	
Ø9	<8	
Ø10	<15	
Ø11~200	<30	

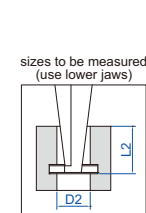

sizes to be measured (use lower jaws)		(mm)
D2	L2	
Ø17	<16	
Ø18	<28	
Ø19	<40	
Ø20	<50	
Ø21	<58	
Ø22-200	<70	

Code	Range of upper jaw	Range of lower jaw	Accuracy	L	a
1176-150	9-150mm/0.35-6"	17-150mm/0.70-6"	±0.04mm	260mm	3mm
1176-200	9-200mm/0.35-8"	17-200mm/0.70-8"	±0.05mm	320mm	3.5mm



DIGITAL INSIDE GROOVE CALIPER

DATA OUTPUT

- Non waterproof
- Measure diameter of grooves inside bores
- Resolution: 0.01mm/0.0005"
- Buttons: on/off, set, mm/inch, preset (+, -)
- Battery CR2032
- Data output
- Made of stainless steel
- Optional accessory: depth stop (code 6143), data output cable (code 7315-21 receiver is needed, 7302-21)



1178-300

Code	Range	Accuracy
1178-300	25-300mm/1.18-12"	±0.05mm

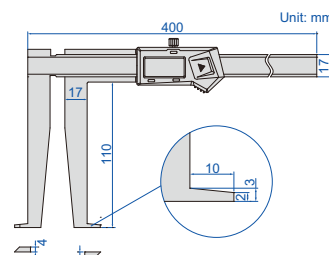
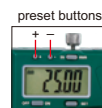

INSIDE GROOVE CALIPER

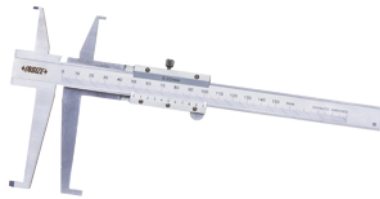

1199-150

- Measure diameter of grooves inside bores
- Graduation: 0.02mm
- Made of stainless steel
- Optional accessory: depth stop (code 6143)

Code	Range of upper jaw	Range of lower jaw	Accuracy
1199-150	9-150mm	18-150mm	±0.04mm

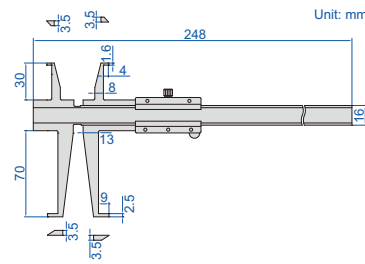

depth stop 6143 (optional)



sizes to be measured (use upper jaws)

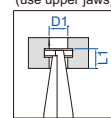

(mm)	
D1	L1
Ø9	<8
Ø10	<12
Ø11	<15
Ø12	<20
Ø13-150	<30

sizes to be measured (use lower jaws)

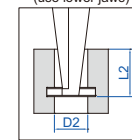

(mm)	
D2	L2
Ø18	<30
Ø19	<40
Ø20	<45
Ø21	<55
Ø22	<60
Ø23-150	<70

INSIDE GROOVE DIAL CALIPERS

SHOCK PROOF

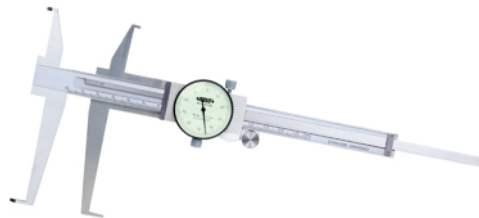

1376-150

- Measure diameter of grooves inside bores
- Shockproof dial indicator
- Dial indicator graduation: 0.02mm
- Made of stainless steel
- Optional accessory: depth stop (code 6143)

Code	Range of upper jaw	Range of lower jaw	Accuracy	L
1376-150	11-150mm	18-150mm	±0.03mm	240mm
1376-200	11-200mm	18-200mm	±0.03mm	290mm
1376-300	11-300mm	18-300mm	±0.04mm	390mm

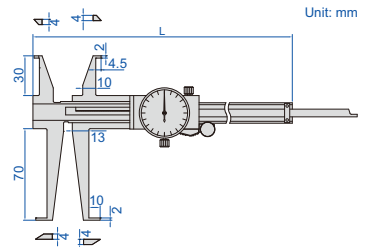

sizes to be measured (use upper jaws)

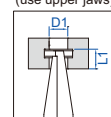

(mm)	
D1	L1
Ø11	<8
Ø12	<10
Ø13	<15
Ø14	<20
Ø15-300	<30

sizes to be measured (use lower jaws)

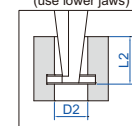

(mm)	
D2	L2
Ø18	<20
Ø19	<28
Ø20	<35
Ø21	<40
Ø22	<50
Ø23-300	<70

DIGITAL INSIDE GROOVE CALIPER

DATA OUTPUT



1191-150

- Non waterproof
- Upper jaws for measuring diameter of grooves
- Resolution: 0.01mm/0.0005"
- Buttons: on/off, zero, mm/inch
- Automatic power off, move the digital unit to turn on power
- Battery CR2032, data output
- Made of stainless steel
- Optional accessory: data output cable (code 7315-21 receiver is needed, 7302-21)

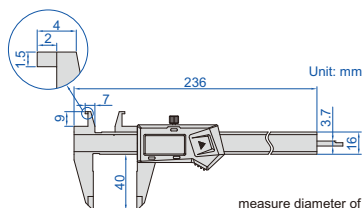

measure diameter of grooves 8-150mm

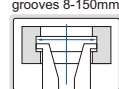

Code	Range of upper jaw	Range of lower jaw	Accuracy
1191-150	8-150mm/0.3-6"	0-150mm/0-6"	±0.03mm

INSIDE GROOVE VERNIER CALIPER

measure depth of grooves (h<10mm)

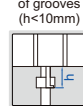

1291-150

measure diameter of grooves 8-150mm

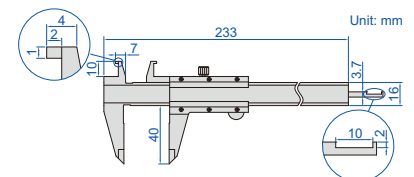
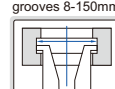

- Made of stainless steel
- Satin chrome plated reading surface

Code	Range of upper jaw	Range of lower jaw	Accuracy	Graduation
1291-150	8-150mm	0-150mm	±0.03mm	0.02mm

DIGITAL OUTSIDE NECK CALIPER

DATA OUTPUT



1187-150A

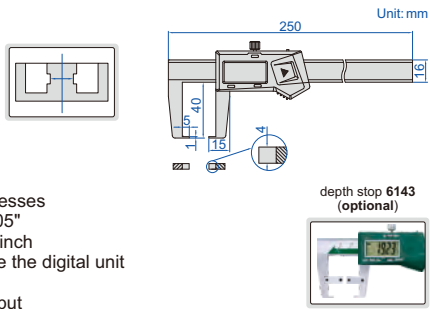

- Non waterproof
- Measure grooves and recesses
- Resolution: 0.01mm/0.0005"
- Buttons: on/off, zero, mm/inch
- Automatic power off, move the digital unit to turn on power
- Battery CR2032, data output
- Made of stainless steel
- Optional accessory: depth stop (code 6143), data output cable (code 7315-21 receiver is needed, 7302-21)

Code	Range	Accuracy
1187-150A	0-150mm/0-6"	±0.04mm

DIGITAL OUTSIDE POINT CALIPER

DATA OUTPUT



1185-150A

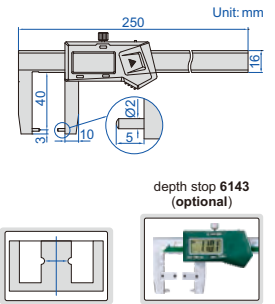

- Non waterproof
- Measure wall thickness inside bores and recesses
- Resolution: 0.01mm/0.0005"
- Buttons: on/off, zero, mm/inch
- Automatic power off, move the digital unit to turn on power
- Battery CR2032
- Data output
- Made of stainless steel
- Optional accessory: depth stop (code 6143), data output cable (code 7315-21 receiver is needed, 7302-21)

Code	Range	Accuracy
1185-150A	0-150mm/0-6"	±0.04mm

DEPTH STOP FOR CALIPERS

- Supplied in pairs
- Made of stainless steel
- Suitable for caliper series 1124, 1526, 1530, 1520, 1176, 1178, 1178, 1120, 1121, 1187 and 1185



6143

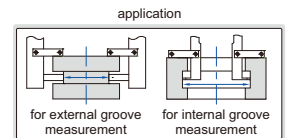
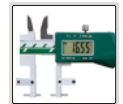
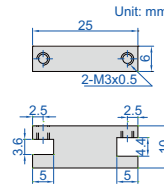

Code
6143

DIGITAL SMALL POINT CALIPER

DATA OUTPUT



1169-150

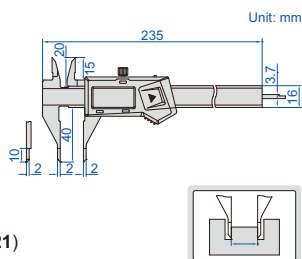

- Non waterproof
- Small pointed jaws fit into small grooves and recesses
- Resolution: 0.01mm/0.0005"
- Buttons: on/off, zero, mm/inch
- Automatic power off, move the digital unit to turn on power
- Battery CR2032, data output
- Made of stainless steel
- Optional accessory: data output cable (code 7315-21 receiver is needed, 7302-21)

Code	Range	Accuracy
1169-150	0-150mm/0-6"	±0.03mm

DIGITAL POINT CALIPER

DATA OUTPUT



1183-150A

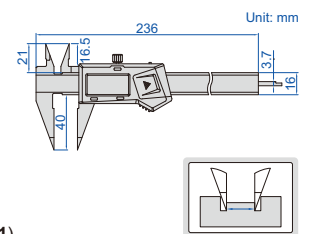

- Non waterproof
- Pointed jaws fit into small grooves and recesses
- Resolution: 0.01mm/0.0005"
- Buttons: on/off, zero, mm/inch
- Automatic power off, move the digital unit to turn on power
- Battery CR2032, data output
- Made of stainless steel
- Optional accessory: data output cable (code 7315-21 receiver is needed, 7302-21)

Code	Range	Accuracy
1183-150A	0-150mm/0-6"	±0.03mm

DIGITAL BLADE CALIPER

- Non waterproof
- The blade jaws fit into small grooves
- Resolution: 0.01mm/0.0005"
- Buttons: on/off, zero, mm/inch
- Automatic power off, move the digital unit to turn on power
- Battery CR2032, data output
- Made of stainless steel
- Optional accessory: data output cable (code 7315-21 receiver is needed, 7302-21)



1188-150A

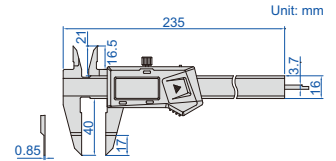
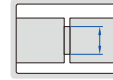

DATA OUTPUT

Code	Range	Accuracy
1188-150A	0-150mm/0-6"	±0.03mm

DIGITAL OFFSET CENTERLINE CALIPERS

- Non waterproof
- Measure hole center distance in the same or offset planes
- Resolution: 0.01mm/0.0005"
- Buttons: on/off, set, mm/inch, preset (+, -)
- Automatic power off, move the digital unit to turn on power
- Battery CR2032, data output
- Made of stainless steel



1192-150A

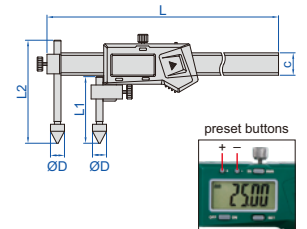

DATA OUTPUT

With data interface

Code	Range	Accuracy	c	ØD	L1	L2	L	Data output cable (optional)
1192-150A	10-150mm/0.4-6"	±0.05mm	16mm	10mm	46mm	79mm	236mm	7315-21 receiver is needed, 7302-21
1192-300A	10-300mm/0.4-12"	±0.09mm	16mm	10mm	46mm	79mm	396mm	7315-21 receiver is needed, 7302-21
1192-500A	20-500mm/0.8-20"	±0.09mm	24mm	20mm	52mm	112mm	725mm	7315-22 receiver is needed, 7302-22

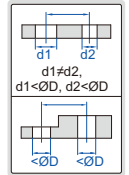

DIGITAL BACK-JAW CENTERLINE CALIPER

- Non waterproof
- Measure hole center distance in the same or offset planes
- Resolution: 0.01mm/0.0005"
- Buttons: on/off, set, mm/inch, preset (+, -)
- Automatic power off, move the digital unit to turn on power
- Battery CR2032
- Data output
- Made of stainless steel
- Optional accessory: data output cable (code 7315-21 receiver is needed, 7302-21)



1177-200

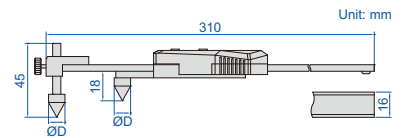

DATA OUTPUT

Code	Range	Accuracy	ØD
1177-200	10-200mm/0.4-8"	±0.10mm	10mm

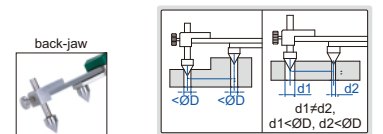

DIGITAL BACK-JAW EDGE TO CENTER CALIPERS

- Non waterproof
- Measure edge to hole center distance
- Resolution: 0.01mm/0.0005"
- Buttons: on/off, set, mm/inch, preset (+, -)
- Automatic power off, move the digital unit to turn on power
- Battery CR2032
- Data output
- Made of stainless steel
- Optional accessory: data output cable (code 7315-21 receiver is needed, 7302-21)



1524-200

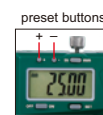

DATA OUTPUT

Code	Range	Accuracy	L
1524-200	5-200mm/0.2-8"	±0.1mm	310mm
1524-300	5-300mm/0.2-12"	±0.1mm	410mm

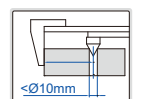
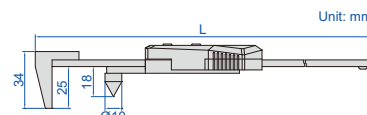

DIGITAL CENTERLINE AND EDGE TO CENTER CALIPERS

DATA OUTPUT

- Non waterproof
- Measure hole center distance or edge to hole center distance
- Resolution: 0.01mm/0.0005"
- Buttons: on/off, set, mm/inch, preset (+, -)
- Automatic power off, move the digital unit to turn on power
- Battery CR2032
- Data output
- Made of stainless steel



1525-300

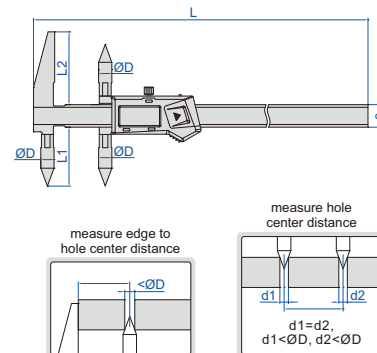

With data interface

Code	Range of upper jaw (edge to center)	Range of lower jaw (center to center)	Accuracy	ØD	L1	L2	c	L	Data output cable (optional)
1525-300	5-300mm/0.2-12"	10-300mm/0.4-12"	±0.08mm	10mm	44.5mm	55mm	17mm	410mm	7315-21 receiver is needed, 7302-21
1525-500	10-500mm/0.4-20"	20-50mm/0.8-20"	±0.09mm	20mm	50mm	60mm	24mm	690mm	7315-22 receiver is needed, 7302-22
1525-1000	15-1000mm/0.6-40"	30-1000mm/1.2-40"	±0.12mm	30mm	70mm	81mm	31mm	1255mm	7315-22 receiver is needed, 7302-22
1525-1500	15-1500mm/0.6-60"	30-1500mm/1.2-60"	±0.15mm	30mm	70mm	81mm	31mm	1760mm	7315-22 receiver is needed, 7302-22

DIGITAL CENTERLINE AND EDGE TO CENTER CALIPERS

DATA OUTPUT

- Non waterproof
- Measure hole center distance in the same or offset planes and edge to hole center distance
- Resolution: 0.01mm/0.0005"
- Buttons: on/off, set, mm/inch, preset (+, -)
- Automatic power off, move the digital unit to turn on power
- Battery CR2032, data output
- Made of stainless steel
- Optional accessory: data output cable (code 7315-21 receiver is needed, 7302-21)

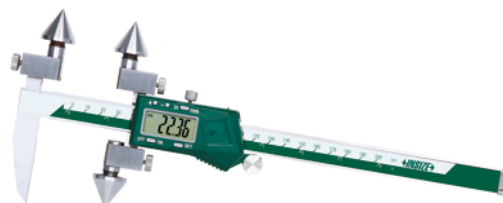

1521-2002

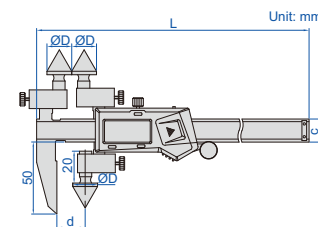

Code	Range	Accuracy	ØD	L	c	d
1521-150	5-150mm/0.2-6"	±0.05mm	5mm	236mm	16mm	5mm
1521-1501	10-150mm/0.4-6"	±0.05mm	10mm	236mm	16mm	10mm
1521-1502	20-150mm/0.8-6"	±0.05mm	20mm	236mm	16mm	20mm
1521-200	5-200mm/0.2-8"	±0.05mm	5mm	285mm	16mm	5mm
1521-2001	10-200mm/0.4-8"	±0.05mm	10mm	285mm	16mm	10mm
1521-2002	20-200mm/0.8-8"	±0.05mm	20mm	285mm	16mm	20mm
1521-300	5-300mm/0.2-12"	±0.07mm	5mm	385mm	17mm	5mm
1521-3001	10-300mm/0.4-12"	±0.07mm	10mm	385mm	17mm	10mm
1521-3002	20-300mm/0.8-12"	±0.07mm	20mm	385mm	17mm	20mm

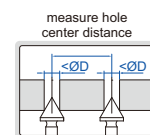
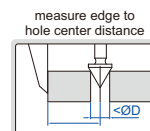

DIGITAL HOOK CALIPER

DATA OUTPUT

- Non waterproof
- Accuracy: ±0.04mm
- Measure width and distance of grooves inside bores
- Resolution: 0.01mm/0.0005"
- Buttons: on/off, zero, mm/inch
- Automatic power off, move the digital unit to turn on power
- Battery CR2032, data output
- Made of stainless steel
- Optional accessory: data output cable (code 7315-21 receiver is needed, 7302-21)



1122-300

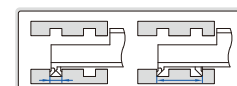
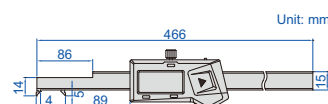

Code	Range
1122-300	4-300mm/0.16-12"

DIGITAL OFFSET CALIPER

DATA
OUTPUT

- Non waterproof
- The left jaw can slide up and down to facilitate measurement of stepped sections
- Resolution: 0.01mm/0.0005"
- Buttons: on/off, zero, mm/inch
- Automatic power off, move the digital unit to turn on power
- Battery CR2032, data output
- Made of stainless steel
- Optional accessory: data output cable (code 7315-21 receiver is needed, 7302-21)



1186-150A

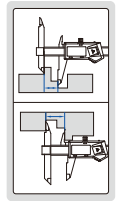
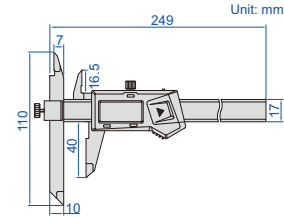

Code	Range	Accuracy
1186-150A	0-150mm/0-6"	±0.04mm

DIGITAL TUBE THICKNESS CALIPER

DATA
OUTPUT

- Non waterproof
- Measure wall thickness of tubes
- Resolution: 0.01mm/0.0005"
- Buttons: on/off, zero, mm/inch
- Automatic power off, move the digital unit to turn on power
- Battery CR2032, data output
- Made of stainless steel
- Optional accessory: data output cable (code 7315-21 receiver is needed, 7302-21)



1161-150A

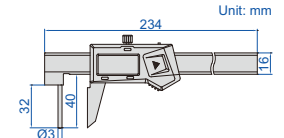
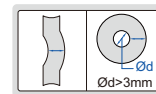

Code	Range	Accuracy
1161-150A	0-150mm/0-6"	±0.05mm

DIGITAL CRIMP HEIGHT CALIPER

DATA
OUTPUT

- Non waterproof
- Measure crimp height
- Resolution: 0.01mm/0.0005"
- Buttons: on/off, zero, mm/inch
- Automatic power off, move the digital unit to turn on power
- Battery CR2032
- Data output
- Meet DIN862
- Made of stainless steel
- Optional accessory: data output cable (code 7315-21 receiver is needed, 7302-21)



1165-150A

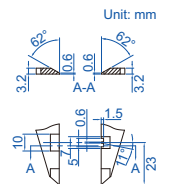
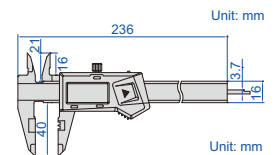

Code	Range	Accuracy
1165-150A	0-150mm/0-6"	±0.03mm



DIGITAL CALIPER WITH LARGE MEASURING FACES

DATA
OUTPUT

- Non waterproof
- Measure diameter of wire ropes, and thickness of soft materials like rubber, sponge, etc.
- Resolution: 0.01mm/0.0005"
- Buttons: on/off, zero, mm/inch
- Automatic power off, move the digital unit to turn on power
- Battery CR2032
- Data output
- Made of stainless steel
- Optional accessory: data output cable (code 7315-21 receiver is needed, 7302-21)

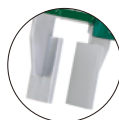

1172-200

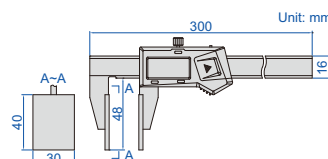

measure diameter of wire ropes

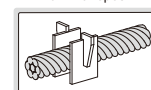

measure thickness of rubber, sponge, etc.



Code	Range	Accuracy
1172-200	0-200mm/0-8"	±0.07mm

DIGITAL V SHAPE CALIPER

DIRECT READING,
CALCULATION IS NOT REQUIRED

DATA
OUTPUT



1539-3

- Non waterproof
- Measure outside diameter of three number of flutes (such as taps, reamers, end mills and gears)
- Resolution: 0.01mm/0.0005"
- Buttons: on/off, zero, mm/inch
- Battery CR2032, data output
- Automatic power off, move the digital unit to turn on power
- Made of stainless steel
- Optional accessory: data output cable (code 7315-21 receiver is needed, 7302-21)

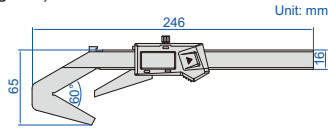

Code	Range	Accuracy
1539-3	Ø4-40mm/0.16-1.58" DIA	±0.03mm

V SHAPE VERNIER CALIPER



1273-403

- Accuracy: ±0.05mm
- Measure outside diameter of three number of flutes (such as taps, reamers, end mills and gears)
- Made of stainless steel
- Satin chrome plated reading surface

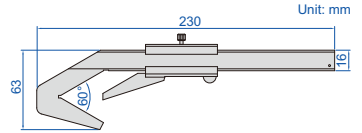

Code	Range	Graduation
1273-403	Ø4-40mm	0.05mm

V SHAPE VERNIER CALIPERS

- Measure outside diameter of odd number of flutes (such as taps, reamers, end mills and gears)
- Made of stainless steel
- Satin chrome plated reading surface
- Optional accessory: 4mm pin gage (code 4110-4D00), Ø50mm calibration cylinder (code 6316-50)



1229-3

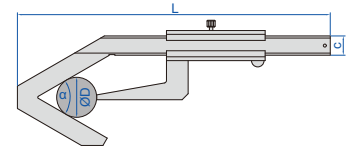

Code	Range (ØD)	Graduation	Accuracy	Flutes	Angle α	L	c
1229-3	Ø4-60mm	0.02mm	±0.04mm	3	60°	260mm	16mm
1229-35	Ø50-200mm	0.02mm	±0.06mm	3	60°	516mm	20mm
1229-5	Ø4-60mm	0.02mm	±0.04mm	5	108°	210mm	16mm
1229-55	Ø50-200mm	0.02mm	±0.06mm	5	108°	360mm	20mm

DIGITAL GEAR TOOTH CALIPERS

ATTENTION: NO
DATA OUTPUT

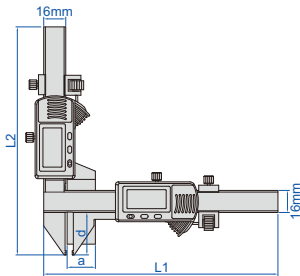

1181-M25A

- Non waterproof
- Resolution: 0.01mm/0.0005"
- Accuracy of height measurement: ±0.03mm
- Accuracy of thickness measurement: ±0.03mm
- Carbide tips
- Measure the tooth thickness by positioning the tooth height (for tooth height>1mm)
- Buttons: zero, on/off, mm/inch
- Automatic power off, move the digital unit to turn on power
- Battery CR2032
- Made of stainless steel

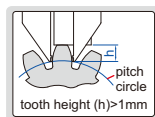

(mm)

Code	Range	Total accuracy	L1	L2	a	d
1181-M25A	M1-25mm	±0.04mm	170	165.5	21	30.5
1181-M50A	M5-50mm	±0.04mm	220	190	50.5	55

GEAR TOOTH VERNIER CALIPER

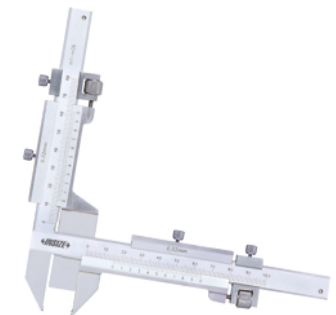
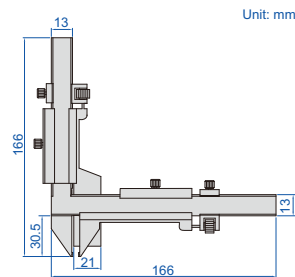

1281-M26A

- Graduation: 0.02mm
- Accuracy of thickness measurement: ±0.03mm
- Carbide tips
- Measure the tooth thickness by positioning the tooth height (for tooth height>1mm)
- Made of stainless steel
- Satin chrome plated reading surface

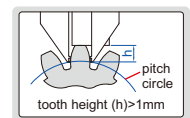

Code	Range	Accuracy of height measurement	Total accuracy
1281-M26A	M1-26mm	±0.03mm	±0.04mm



Digital Depth Gages
Page 25-26



Dial Depth Gages
Page 27



Vernier Depth Gages
Page 27



Extension Bases
Page 27



Mini Depth Gages
Page 27-28



Depth Gages
Page 28-29



Depth Micrometers
Page 29

IP67 WATERPROOF DIGITAL DEPTH GAGES

ATTENTION: NO DATA OUTPUT

IP67 WATERPROOF

- IP67 dust/waterproof
- Resolution: 0.01mm/0.0005"
- Button function: zero, on/off, mm/inch
- Battery CR2032
- Automatic power off
- Meet DIN862
- Made of stainless steel



1543-150

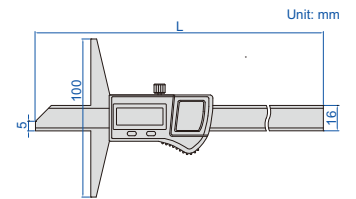

Code	Range	Accuracy	L
1543-150	0-150mm/0-6"	±0.03mm	235mm
1543-200	0-200mm/0-8"	±0.03mm	285mm
1543-300	0-300mm/0-12"	±0.03mm	387mm

DIGITAL DEPTH GAGES (STANDARD TYPE)

DATA OUTPUT

POPULAR MODEL

- Non waterproof
- Resolution: 0.01mm/0.0005"
- Buttons: on/off, zero, mm/inch
- Automatic power off, move the digital unit to turn on power
- Meet DIN862 (except 0-500mm/0-20")
- Battery CR2032, data output
- Made of stainless steel



1141-150A

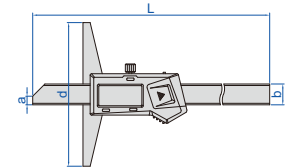

(mm)

Code	Range	Accuracy	L	a	b	d	Data output cable (optional)
1141-150A	0-150mm/0-6"	±0.03mm	230	6	14.5	100	7315-21 receiver is needed, 7302-21
1141-200A	0-200mm/0-8"	±0.03mm	280	6	14.5	100	7315-21 receiver is needed, 7302-21
1141-300A	0-300mm/0-12"	±0.03mm	380	6	14.5	150	7315-21 receiver is needed, 7302-21
1141-500A	0-500mm/0-20"	±0.05mm	585	7	15	150	7315-22 receiver is needed, 7302-22
1141-5001A	0-500mm/0-20"	±0.05mm	585	7	15	200	7315-22 receiver is needed, 7302-22

DIGITAL DEPTH GAGES WITH MOUNTING HOLES FOR EXTENSION BASE

DATA OUTPUT

- Non waterproof
- Resolution: 0.01mm/0.0005"
- Buttons: on/off, zero, mm/inch
- Automatic power off, move the digital unit to turn on power
- Meet DIN862
- Battery CR2032, data output
- Made of stainless steel
- Optional accessory: data output cable (code 7315-21 receiver is needed, 7302-21), extension base (code 6141)



1147-300

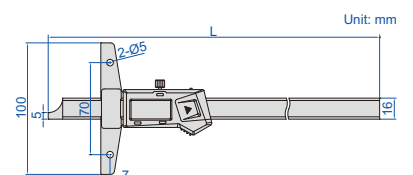

Code	Range	Accuracy	L
1147-150	0-150mm/0-6"	±0.03mm	237mm
1147-200	0-200mm/0-8"	±0.03mm	287mm
1147-300	0-300mm/0-12"	±0.03mm	403mm



DIGITAL HOOK DEPTH GAGES

DATA OUTPUT

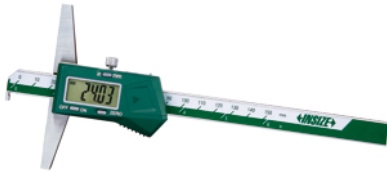

1142-150A

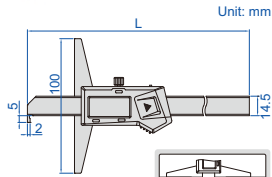

- Non waterproof
- Resolution: 0.01mm/0.0005"
- Buttons: on/off, zero, mm/inch
- Automatic power off, move the digital unit to turn on power
- Battery CR2032, data output
- Made of stainless steel
- Optional accessory: data output cable (code 7315-21 receiver is needed, 7302-21)

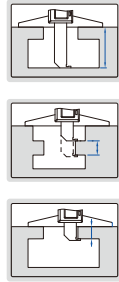

Code	Range	Accuracy	L
1142-150A	0-150mm/0-6"	±0.03mm	230mm
1142-200A	0-200mm/0-8"	±0.03mm	280mm

DIGITAL POINT DEPTH GAGE

DATA OUTPUT

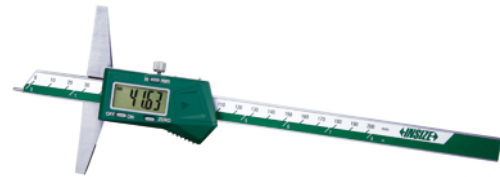

1143-200A

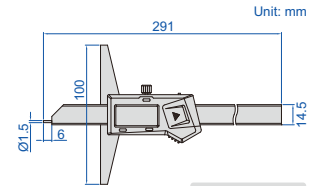

- Non waterproof
- Resolution: 0.01mm/0.0005"
- Buttons: on/off, zero, mm/inch
- Automatic power off, move the digital unit to turn on power
- Meet DIN862
- Battery CR2032, data output
- Made of stainless steel
- Optional accessory: data output cable (code 7315-21 receiver is needed, 7302-21)

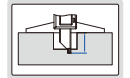

Code	Range	Accuracy
1143-200A	0-200mm/0-8"	±0.03mm

DIGITAL DOUBLE HOOK DEPTH GAGES

DATA OUTPUT

- Non waterproof
- Resolution: 0.01mm/0.0005"
- Buttons: on/off, zero, mm/inch
- Automatic power off, move the digital unit to turn on power
- Meet DIN862
- Battery CR2032
- Data output
- Made of stainless steel
- Optional accessory: data output cable (code 7315-21 receiver is needed, 7302-21)



1144-150A

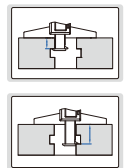
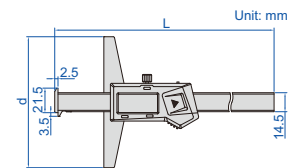

Code	Range	Accuracy	L	d
1144-150A	0-150mm/0-6"	±0.03mm	233mm	100mm
1144-200A	0-200mm/0-8"	±0.03mm	283mm	100mm
1144-300A	0-300mm/0-12"	±0.03mm	383mm	150mm

DIGITAL DEPTH GAGE WITH ROUND DEPTH BAR

MEASURE DEPTH OF SMALL HOLES (>Ø4mm)

DATA OUTPUT

MEASURE WIDTH AND DEPTH OF GROOVES INSIDE BORE

extension base (optional)



1148-200

- Non waterproof
- Resolution: 0.01mm/0.0005"
- Supplied with three interchangeable points (flat, spherical, disk)
- Buttons: on/off, set, mm/inch, preset (+, -)
- Automatic power off, move the digital unit to turn on power
- Battery CR2032, data output
- Made of stainless steel
- Optional accessory: data output cable (code 7315-21 receiver is needed, 7302-21), extension base (code 6141)

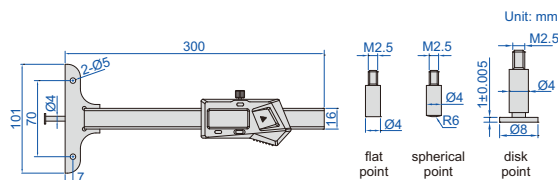

flat point spherical point disk point

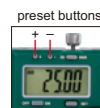
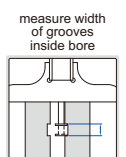
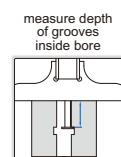
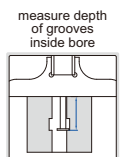
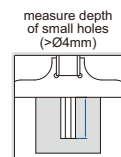

Code	Range*	Accuracy	Remark
1148-200	0-200mm/0-8"	±0.03mm	with mounting holes for extension base

*When disk points are used, the range is reduced by 10mm

DIAL DEPTH GAGES WITH ROUND BAR

SHOCK PROOF



1341-100

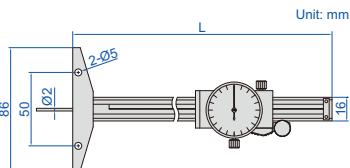

- Shockproof dial indicator
- Dial indicator graduation: 0.02mm
- Made of stainless steel

Code	Range	Accuracy	L
1341-100	0-100mm	±0.02mm	181mm
1341-200	0-200mm	±0.03mm	284mm

DIAL DEPTH GAGES

SHOCK PROOF



1340-150

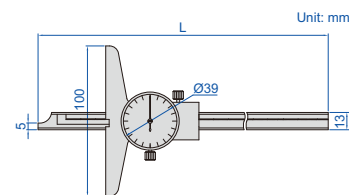

- Shockproof dial indicator
- Made of stainless steel

Code	Range	Graduation	Accuracy	L
1340-150	0-150mm	0.02mm	±0.03mm	232mm
1340-200	0-200mm	0.02mm	±0.03mm	282mm
1340-300	0-300mm	0.02mm	±0.04mm	382mm

VERNIER DEPTH GAGES (STANDARD TYPE)

POPULAR MODEL

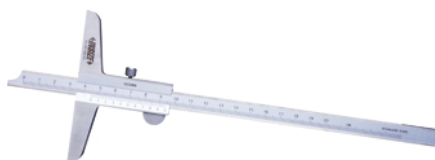

1240-2001

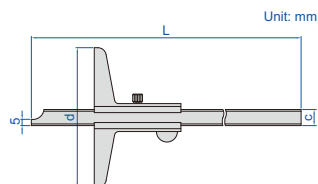

- Made of stainless steel
- Satin chrome plated reading surface

Graduation: 0.02mm

Code	Range	Accuracy	L	d	c
1240-1501	0-150mm	±0.03mm	250mm	100mm	10mm
1240-2001	0-200mm	±0.03mm	300mm	100mm	10mm
1240-3001	0-300mm	±0.04mm	400mm	100mm	10mm
1240-5001	0-500mm	±0.05mm	605mm	150mm	11mm

EXTENSION BASES



6141-260

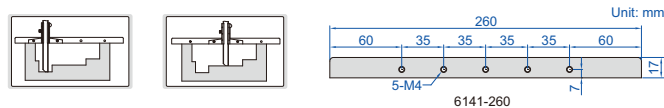

- Supplied with two screws
- Made of stainless steel
- Suitable for depth gages series 1147, 1148, 1247, 1248 and 1249

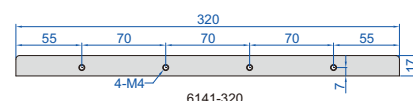

Code	Length
6141-260	260mm
6141-320	320mm

MINI DIGITAL DEPTH GAGES WITH ROUND BAR

DATA OUTPUT



1140-25

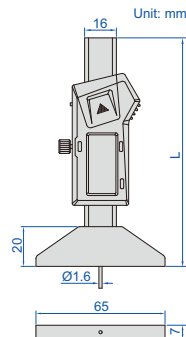

- Non waterproof
- Measure depth of small groove and hole
- Resolution: 0.01mm/0.0005"
- Buttons: on/off, set, mm/inch, preset (+,-)
- Automatic power off, move the digital unit to turn on power
- Battery CR2032
- Made of stainless steel

With data interface

(data output cable code 7315-21 receiver is needed, 7302-21, optional)

Code	Range	Accuracy	L
1140-25	0-25mm/0-1"	±0.02mm	114mm
1140-50	0-50mm/0-2"	±0.02mm	140mm
1140-100	0-100mm/0-4"	±0.02mm	190mm
1140-150	0-150mm/0-6"	±0.03mm	236mm

Built-in wireless (receiver code 7315-2/3/6/7/8/9 is needed)

Code	Range	Accuracy	L
1140-25WL	0-25mm/0-1"	±0.02mm	114mm
1140-50WL	0-50mm/0-2"	±0.02mm	140mm
1140-100WL	0-100mm/0-4"	±0.02mm	190mm
1140-150WL	0-150mm/0-6"	±0.03mm	236mm

MINI DIGITAL DEPTH GAGE

DATA OUTPUT

- Non waterproof
- Measure depth of small groove and hole, also measure depth of tire tread
- Resolution: 0.01mm/0.0005"
- Buttons: on/off, zero, mm/inch
- Supplied with zero set surface
- Automatic power off, move the digital unit to turn on power
- Battery CR2032, data output
- Made of stainless steel
- Optional accessory: data output cable (code **7315-21** receiver is needed, **7302-21**)



1145-25A

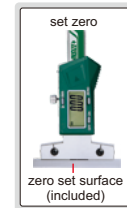
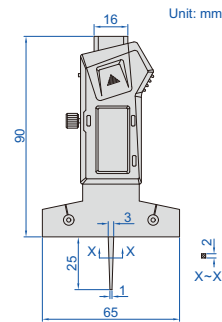

Code	Range	Accuracy
1145-25A	0-25mm/0-1"	±0.03mm

MINI VERNIER DEPTH GAGE

- Graduation: 0.1mm
- Made of stainless steel

Code	Range	Accuracy
1244-30	0-30mm	±0.10mm



1244-30

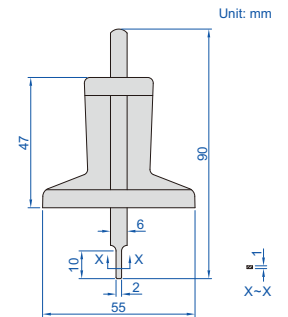

DIAL DEPTH GAGE

- Dial indicator graduation: 0.01mm
- Stainless steel base
- Supplied with pointed tip and ball tip

Code	Range	Dial indicator stroke	Accuracy
2341-101A	0-10mm	10mm	±0.017mm



2341-101A

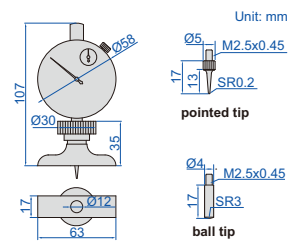

DIAL DEPTH GAGE

- Accuracy: ±0.03mm
- Dial indicator stroke: 30mm
- Dial indicator graduation: 0.01mm
- Stainless steel base
- Extension rods: 25mm (1 pc), 50mm (1 pc), 75mm (1 pc), 100mm (2 pcs)
- Supplied with pointed tip and ball tip
- Optional accessory: granite extension holder (code **2141-10**)



2342-202

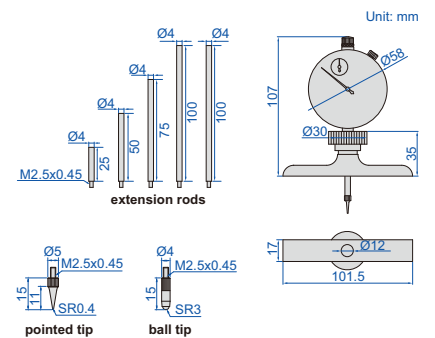

2141-10 (optional), can be customized according to workpieces

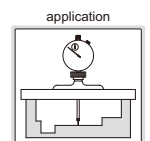
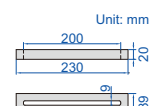

Code	Range	Base
2342-202	0-300mm	101.5x17mm

DIGITAL DEPTH GAGE

DATA OUTPUT

- Digital indicator stroke: 12.7mm/0.5"
- Digital indicator resolution: 0.01mm/0.0005"
- Button function: on/off, zero, mm/inch, ABS, data preset, change measuring direction
- CR2032 battery, data output
- Automatic power off (time is adjustable)
- Stainless steel base
- Extension rods: 12.5mm (1 pc), 25mm (1 pc), 50mm (1 pc), 75mm (1 pc), 100mm (2 pcs)
- Supplied with pointed tip and ball tip
- Optional accessory: data output cable (code 7315-50M receiver is needed, 7302-40M), granite extension holder (code 2141-10)



2141-202A

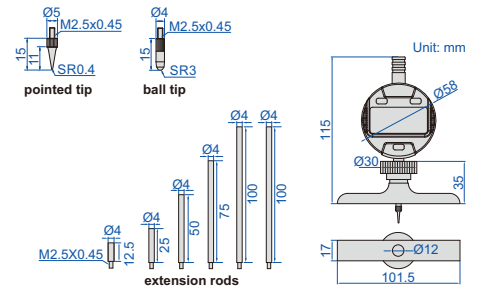

Code	Range	Accuracy	Base
2141-202A	0-300mm/0-12"	$\pm 20\mu\text{m}$	101.5x17mm

2141-10 (optional), can be customized according to workpieces

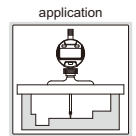
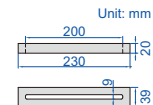

DIGITAL DEPTH MICROMETERS

DATA OUTPUT

IP65 WATERPROOF

- Micrometer head accuracy: $\pm 3\mu\text{m}$
- Rod accuracy: $\pm (2+L/75)\mu\text{m}$, L is the measuring range in mm
- Button function: on/off, set, mm/inch, data transmit
- IP65 dust/waterproof
- Data output
- Automatic power off
- Rods with flat end
- Ratchet stop
- Optional accessory: data output cable (code 7315-31 receiver is needed, 7302-30)



3540-50

Code	Range	Resolution	Rods
3540-50	0-50mm/0-2"	0.001mm/0.00005"	2 pcs
3540-100	0-100mm/0-4"	0.001mm/0.00005"	4 pcs

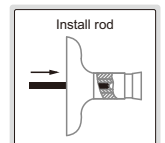
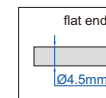
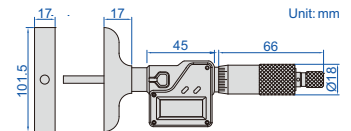

DEPTH MICROMETERS

- Meet DIN863-2
- Micrometer head accuracy: $\pm 3\mu\text{m}$
- Rod accuracy: $\pm (2+L/75)\mu\text{m}$, L is the measuring range in mm
- Rods with flat end
- Ratchet stop

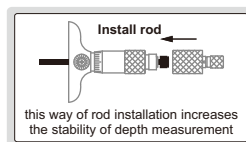

Code	Range	Rods	Graduation
3241-150	0-150mm	6 pcs	0.01mm
3241-300	0-300mm	12 pcs	0.01mm



3241-150

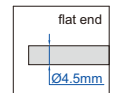
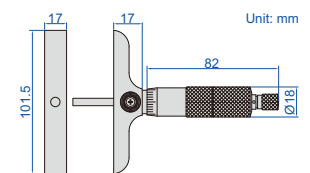

DEPTH MICROMETERS

- Graduation: 0.01mm
- Meet DIN863-2
- Micrometer head accuracy: $\pm 3\mu\text{m}$
- Rod accuracy: $\pm (2+L/75)\mu\text{m}$, L is the measuring range in mm
- Rods with flat end
- Ratchet stop

Code	Range	Rods
3240-25	0-25mm	1 pc
3240-100	0-100mm	4 pcs



3240-25

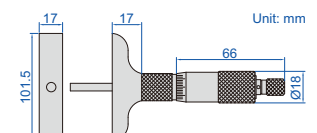
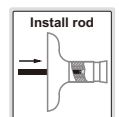
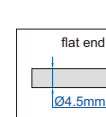



Digital Height Gages
Page 31



Height Gages
Page 32-34

HIGH PRECISION DIGITAL HEIGHT GAGES

DATA OUTPUT

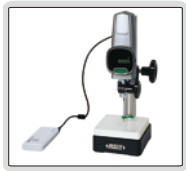

power supplied by charge pal

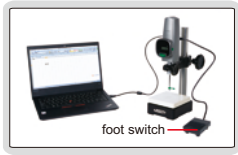

data transmitted to Excel without software, short press the foot switch to transmit data, long press to zero

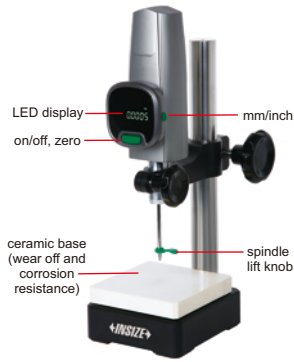

1155-505

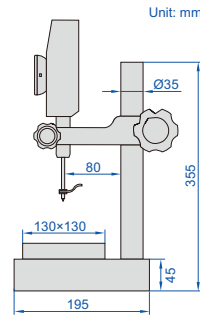

measuring tips (included)

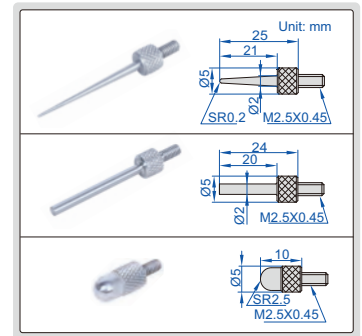

- Range: 0~50mm
- Measuring force: 0.8~1.2N
- Power supply: 5V/1A (adapter or charge pal)
- High stability, high precision, high response speed (5000mm/s)
- High brightness LED display
- Ceramic base flatness: 1µm

Code	Resolution	Accuracy (at 20°C)	Output
1155-505	0.5µm/0.00002" (can switch to: 1µm/0.00005")	1.5µm	USB
1155-510	0.1µm/0.000005" (can switch to: 1µm/0.00005")	1µm	USB

STANDARD DELIVERY

Main unit	1 pc
-----------	------



VIDEO

OPTIONAL ACCESSORY

Contact point	code 6282
Charge pal	1155-5-POB
Data output cable (including foot switch)	1155-5-FOS

DIGITAL HEIGHT GAGE

DATA OUTPUT



power supplied by charge pal

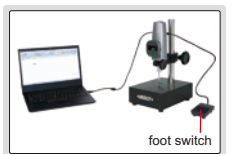

data transmitted to Excel without software



1157-501

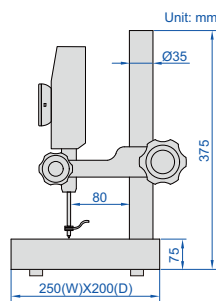

measuring tips (included)

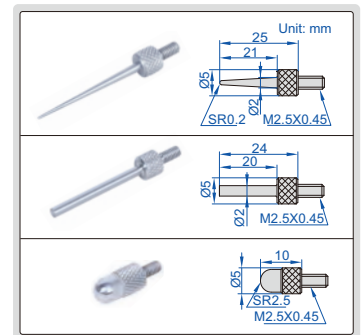

- Measuring force: 0.8~1.2N
- Power supply: 5V/1A (adapter or charge pal)
- Buttons: on/off, zero, mm/inch, max/min/max-min
- High response speed (5000mm/s)
- High brightness LED display



STANDARD DELIVERY

Main unit	1 pc
-----------	------

OPTIONAL ACCESSORY

Contact point	code 6282
Charge pal	1155-5-POB
Data output cable (including foot switch)	1155-5-FOS

Code	Range	Resolution	Accuracy (at 20°C)	Output	Base
1157-501	0~50mm	1µm/0.00005"	3µm	USB	granite (flatness: 2µm)

DIGITAL HEIGHT GAGES

DATA OUTPUT

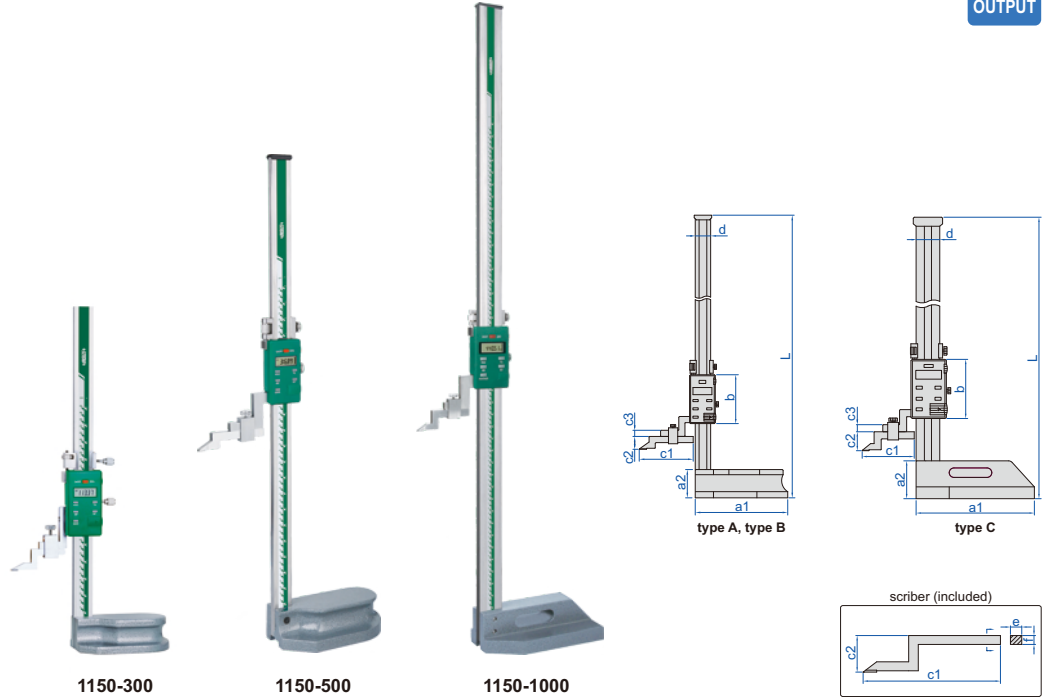
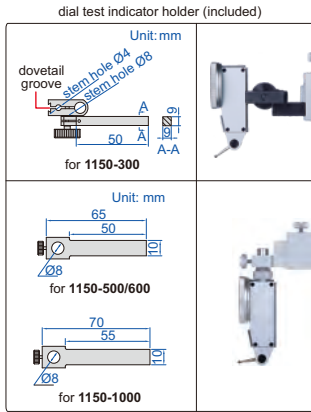

- Non waterproof
- Resolution: 0.01mm/0.0005"
- Buttons: on/off, zero, mm/inch, ABS/INC, data hold, TOL, set
- ABS/INC is for absolute and incremental measurement
- TOL is for tolerance measurement
- Carbide tipped scriber
- Made of stainless steel (except the base)
- LR44 battery, data output
- Supplied with dial test indicator holder
- Supplied with dust cover
- Optional accessory: wireless transmitter (code 7315-1150 receiver is needed), data output cable (code 7302-SPC7, keyboard format), clamp for protractors (code 2372-CLAMP, for 1150-300)

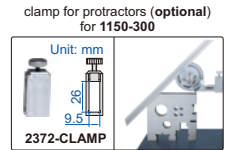

Code	Range	Type	Accuracy	L	a1	a2	b	c1	c2	c3	d	e	f
1150-300	0-300mm/0-12"	A	±0.04mm	485	138	45	95	80	30	10	28	9	9
1150-500	0-500mm/0-20"	B	±0.06mm	720	180	55	95	103	25	12	30	10	12
1150-600	0-600mm/0-24"	B	±0.06mm	820	180	55	95	103	25	12	30	10	12
1150-1000	0-1000mm/0-40"	C	±0.08mm	1275	250	80	125	110	39	15	50	10	15

DIGITAL HEIGHT GAGES WITH DRIVING WHEEL

INSPECTION CERTIFICATE

DATA OUTPUT

POPULAR MODEL

- Non waterproof
- Resolution: 0.01mm/0.0005"
- Buttons: on/off, zero, mm/inch, preset (+, -), ABS/INC
- Automatic power off, move the digital unit to turn on power
- Carbide tipped scriber
- Made of stainless steel
- Battery CR2032, data output
- Supplied with dust cover
- With dial test indicator holder
- Optional accessory: data output cable (code 7302-22), wireless data transmission (transmitter code 7315-22 receiver is needed), clamp for protractors (code 2372-CLAMP)

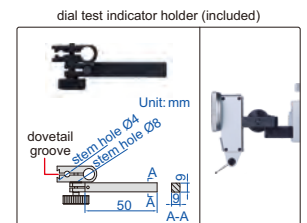
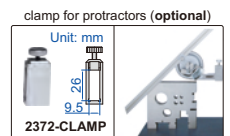
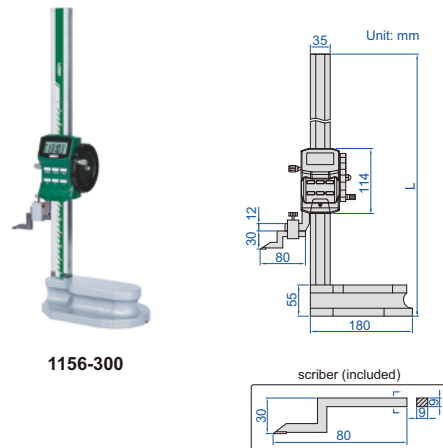

Code	Range	Accuracy	L
1156-300*	0-300mm/0-12"	±0.03mm	515mm
1156-600*	0-600mm/0-24"	±0.05mm	815mm

*Supplied with manufacturer inspection certificate

DIGITAL HEIGHT GAGES

DATA OUTPUT

- Non waterproof
- Resolution: 0.01mm/0.0005"
- Buttons: on/off, zero, mm/inch, data hold, ABS/INC, preset
- ABS/INC is for absolute and incremental measurement
- Automatic power off, move the digital unit to turn on power
- Carbide tipped scriber
- Made of stainless steel
- Battery CR2032, data output
- With driving wheel
- With dial test indicator holder
- Supplied with dust cover
- Optional accessory: clamp for protractors (code **2372-CLAMP**), wireless transmitter (code **7315-1151** receiver is needed), data output cable (code **7302-1151**, keyboard format)

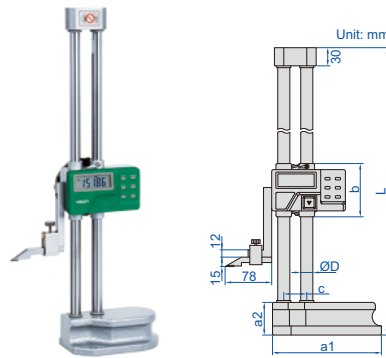

1151-300A

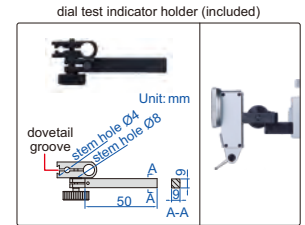
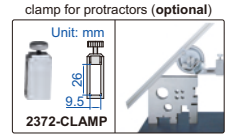
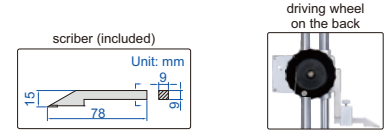

Code	Range	Accuracy	L	a1	a2	b	c	ØD
1151-300A	0-300mm/0-12"	±0.04mm	475mm	135mm	43mm	84mm	33mm	15mm
1151-600A	0-600mm/0-24"	±0.05mm	810mm	180mm	54mm	88mm	38mm	20mm

DIAL HEIGHT GAGES

- Dial indicator graduation: 0.01mm
- One counter reads in the plus direction and another in the minus direction, so incremental measurement can be made in either direction
- Carbide tipped scriber
- Made of stainless steel (except the base)
- With driving wheel
- With dial test indicator holder
- Supplied with dust cover
- Optional accessory: clamp for protractors (code **2372-CLAMP**)

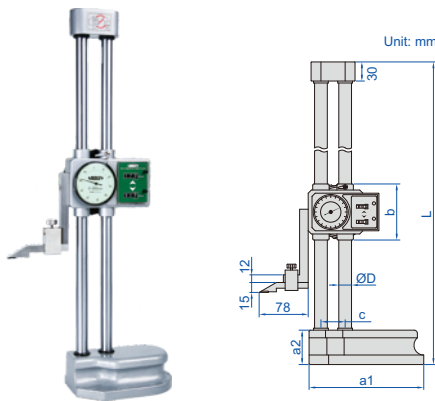

1351-300

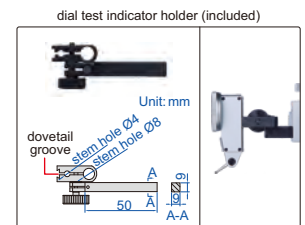
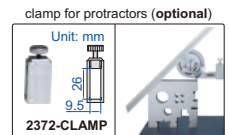
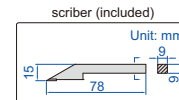

Code	Range	Accuracy	L	a1	a2	b	c	ØD
1351-300	0-300mm	±0.04mm	475mm	135mm	43mm	84mm	33mm	15mm
1351-600	0-600mm	±0.05mm	810mm	180mm	54mm	88mm	38mm	20mm

MINI DIGITAL HEIGHT GAGE

DATA OUTPUT

- Non waterproof
- Buttons: on/off, zero, mm/inch
- Automatic power off, move the digital unit to turn on power
- Carbide tipped scriber
- With fine adjustment
- Made of stainless steel
- Battery CR2032, data output
- Optional accessory: data output cable (code **7315-21** receiver is needed, **7302-21**), dial test indicator holder (code **7151-CL1**)

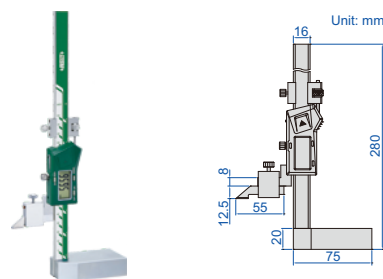

1154-150

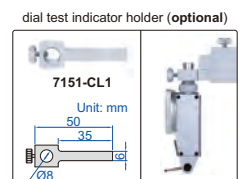
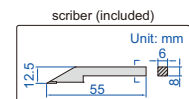

Code	Range	Accuracy	Resolution
1154-150	0-150mm/0-6"	±0.03mm	0.01mm/0.0005"

VERNIER HEIGHT GAGES

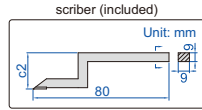
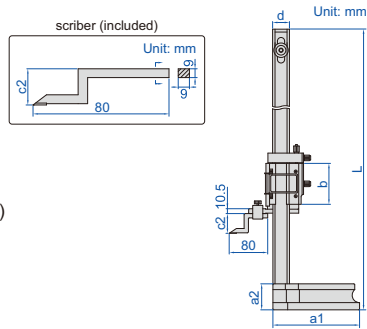

- Graduation: 0.02mm/0.001"
- Adjustable main scale to set zero
- Carbide tipped scribe
- Made of stainless steel (except the base)
- Satin chrome plated scale
- Supplied with magnifier
- With fine adjustment
- Supplied with dust cover
- Optional accessory:
dial test indicator holder (code **6293-6**),
clamp for protractors (code **2372-CLAMP**)



1250-300

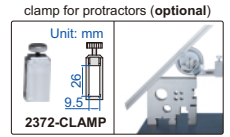

clamp for protractors (optional)
Unit: mm
2372-CLAMP

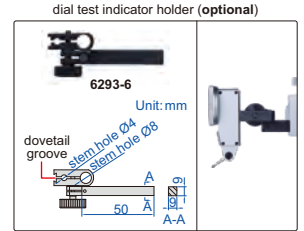

dial test indicator holder (optional)
6293-6
Unit: mm
dovetail groove
stem hole Ø4
stem hole Ø8
A-A

Code	Range	Accuracy	L	a1	a2	b	c2	d
1250-300	0-300mm/0-12"	±0.04mm	545mm	135mm	43mm	75mm	30mm	28mm
1250-600	0-600mm/0-24"	±0.05mm	870mm	180mm	54mm	85mm	41mm	35mm

MINI VERNIER HEIGHT GAGE

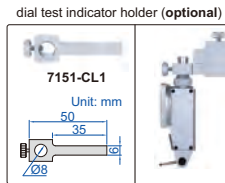

dial test indicator holder (optional)
7151-CL1
Unit: mm

- Graduation 0.02mm/0.001"
- Carbide tipped scribe
- Made of stainless steel (except the base)
- Satin chrome plated scale
- Optional accessory: dial test indicator holder (code **7151-CL1**)



1253-200

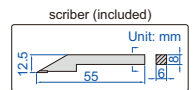
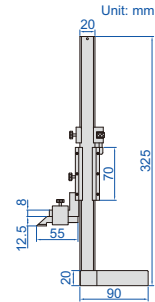

scribe (included)
Unit: mm

Code	Range	Accuracy
1253-200	0-200mm/0-8"	±0.03mm

VERNIER HEIGHT GAGES (BASIC TYPE)

POPULAR MODEL

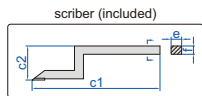
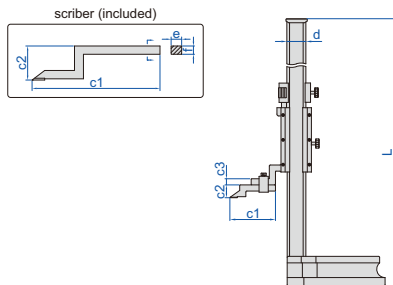

- Graduation: 0.02mm/0.001"
- Carbide tipped scribe
- Made of stainless steel (except the base)
- Satin chrome plated scale
- With dial test indicator holder
- Supplied with dust cover

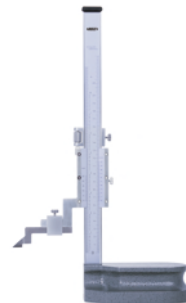

1251-200

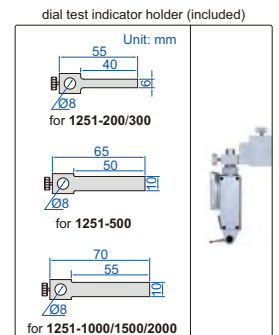

dial test indicator holder (included)
Unit: mm
for 1251-200/300
for 1251-500
for 1251-1000/1500/2000

Code	Range	Accuracy	L	c1	c2	c3	d	e	f
1251-200	0-200mm/0-8"	±0.03mm	370	76	25	10	23	6	8
1251-300	0-300mm/0-12"	±0.04mm	470	76	25	10	23	6	8
1251-500	0-500mm/0-20"	±0.05mm	720	105	25	12	30	10	12
1251-1000	0-1000mm/0-40"	±0.07mm	1275	110	39	15	50	10	15
1251-1500	0-1500mm/0-60"	±0.11mm	1790	110	39	15	50	10	15
1251-2000	0-2000mm/0-80"	±0.14mm	2290	110	39	15	50	10	15



Carbon Fiber Comparison Gages
Page 36



Digital Internal Measuring Gages
Page 37



Internal And External Diameter
Comparison Instrument
Page 38



Outside Diameter Measuring Stands
Page 38

CARBON FIBER COMPARISON GAGES

CARBON FIBER RODS, LIGHT WEIGHT, NOT EASY TO DEFORM, NO TEMPERATURE EXPAND, SUITABLE FOR THIN-WALL WORKPIECES AND LARGE-SIZE WORKPIECES

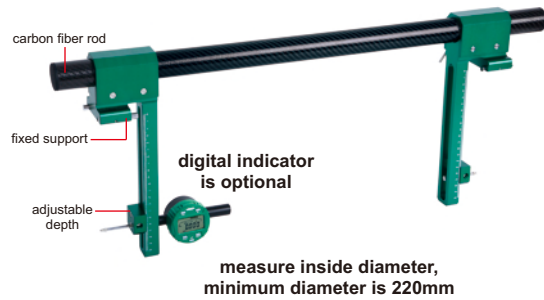
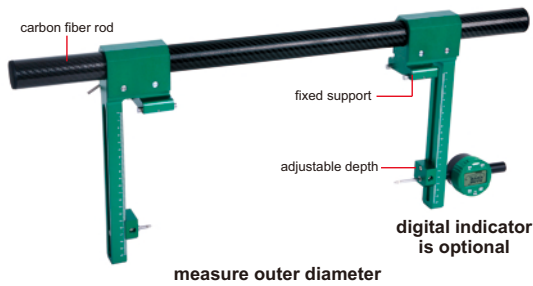

2931-D1000B

application

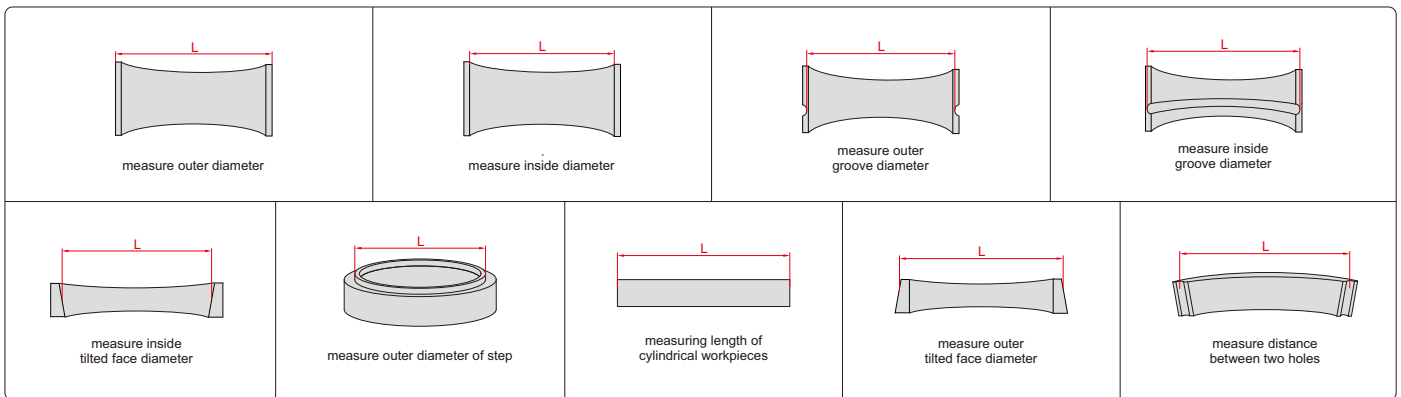

- Measure outer diameter, inside diameter, holes distance and cylindrical workpiece length
- Carbon fiber rods, light weight, not easy to deform, no temperature expand
- Optional accessory: cylinder gage blocks (code 4001), digital indicators (code 2138-25SP/2139-25SP/2103-25SP/2104-25SP)

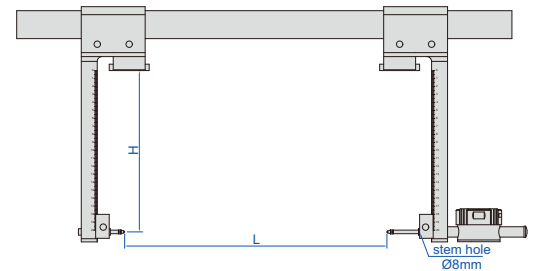

Code	Maximum measuring range (L)	Measuring depth (H)	Repeatability	Weight
2931-D1000A	1000mm	0-100mm	5µm	2.0kg
2931-D1000B	1000mm	0-200mm	10µm	2.3kg
2931-D1000C	1000mm	0-300mm	25µm	2.6kg
2931-D1500A	1500mm	0-100mm	8µm	2.3kg
2931-D1500B	1500mm	0-200mm	15µm	2.6kg
2931-D1500C	1500mm	0-300mm	30µm	2.9kg
2931-D2000A	2000mm	0-100mm	10µm	2.6kg
2931-D2000B	2000mm	0-200mm	20µm	2.9kg
2931-D2000C	2000mm	0-300mm	35µm	3.2kg
2931-D2500A	2500mm	0-100mm	12µm	2.9kg
2931-D2500B	2500mm	0-200mm	25µm	3.2kg
2931-D2500C	2500mm	0-300mm	50µm	3.5kg
2931-D3000A	3000mm	0-100mm	14µm	3.2kg
2931-D3000B	3000mm	0-200mm	30µm	3.5kg
2931-D3000C	3000mm	0-300mm	60µm	3.8kg
2931-D4000A	4000mm	0-100mm	16µm	3.8kg
2931-D4000B	4000mm	0-200mm	35µm	4.1kg
2931-D4000C	4000mm	0-300mm	65µm	4.4kg

DATA OUTPUT

DIGITAL INTERNAL MEASURING GAGES

- Measure internal dimensions
- Resolution: 0.001mm/0.00005"
- Accuracy: 5µm
- Repeatability: 1µm
- Movable point stroke: 5mm/0.02"
- Point height is adjustable, h=2-25mm
- CR2032 battery, automatic power off (time is adjustable)
- Data output

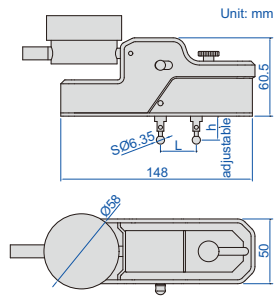

2932-45



2932-451

Code	Measuring range (L) *	Indicator	Data output cable (optional)
2932-45	20-45mm/0.8-1.8"	Button function: on/off, inch/mm, zero, data preset, change measuring direction, absolute/incremental measurement	7315-50M (receiver is needed), 7302-40M
2932-451	20-45mm/0.8-1.8"	With transmission button and signal light Reading in digital and analog Display can be rotated by 320° Button function: on/off, inch/mm, zero, data preset, change measuring direction, absolute/incremental measurement, max./min./TIR measurement, tolerance Go and No-Go display	7315-51 (receiver is needed), 7302-40M

* The measuring range will change accordingly for different measuring points

Disk points (optional, supplied in pair)

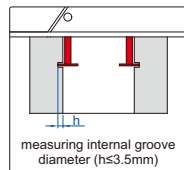
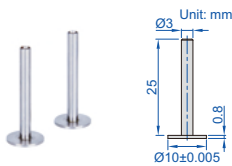

Code	Measuring range	Material
2932-S101	30-55mm/1.2-2.2"	stainless steel

Conical points (optional, supplied in pair)

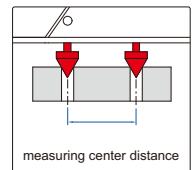
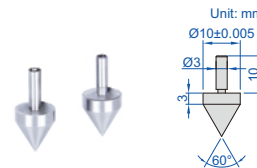

Code	Measuring range	Material
2932-S102	20-45mm/0.8-1.8"	stainless steel

Spherical points (optional, supplied in pair)

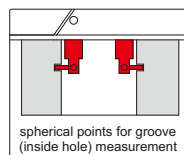

Code	Measuring range	Material
2932-S103	30-60mm/1.2-2.4"	stainless steel

Spherical blade points (optional, supplied in pair)

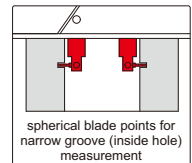

Code	Measuring range	Material
2932-S104	30-60mm/1.2-2.4"	stainless steel

Ball points (optional, supplied in pair)

Code	Diameter (D)	Accuracy of diameter	Material
1527-T102	1/8" (Ø3.175mm)	±0.005mm	stainless steel
1527-T103	3/16" (Ø4.7625mm)	±0.005mm	stainless steel
1527-T104	1/4" (Ø6.35mm)	±0.005mm	stainless steel
1527-T105	3/8" (Ø9.525mm)	±0.005mm	stainless steel
1527-T106	1/2" (Ø12.7mm)	±0.005mm	stainless steel

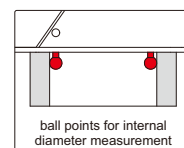
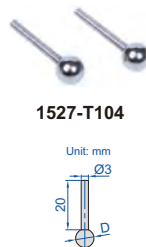

Point sleeve (optional, supplied in pair)

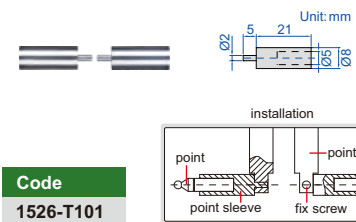

Code
1526-T101

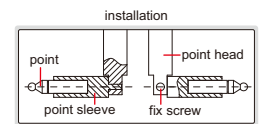

Multifunctional points 7392* (optional, supplied in pair)



Ball points 7391* (optional, supplied in pair)



Screw thread points 7321* (optional, supplied in pair)



* It is necessary to use point sleeve (code 1526-T101) for these points

INTERNAL AND EXTERNAL DIAMETER COMPARISON INSTRUMENT

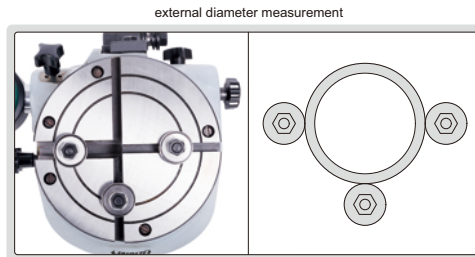
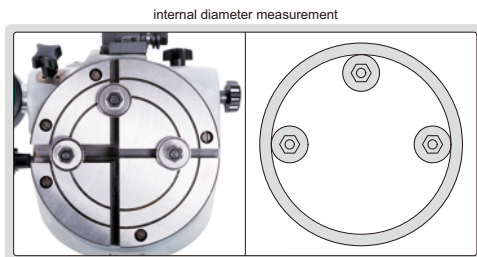
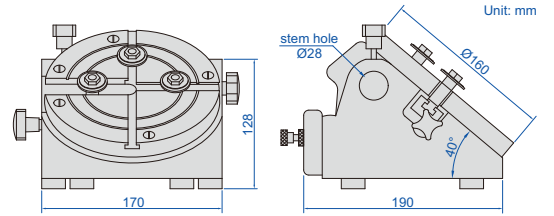
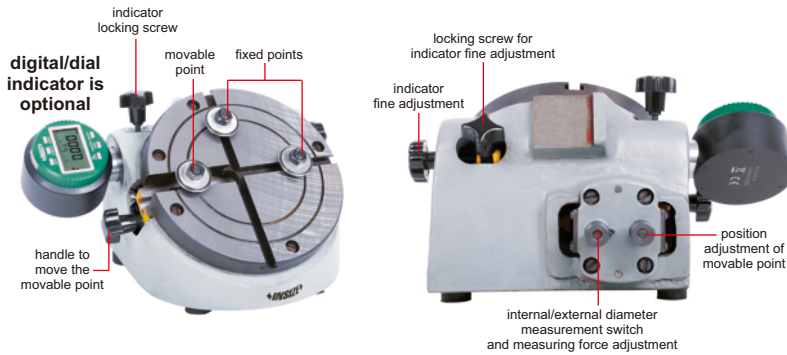

Ø28mm/Ø8mm bush (optional)

Code
6843-B8

- Measure internal/external diameter, variation and taper
- Total range of movable point: 2mm, effective range of movable point: ±0.1mm
- Optional accessory: Ø28mm/Ø8mm bush (code **6843-B8**), 0.001mm digital/dial indicators, high precision digital indicators (code **2140-6**, **2140-6WL**)

Code	Applicable holding stem	Range of internal diameter	Range of external diameter	Accuracy	Repeatability
6843-140	Ø28mm	50-140mm/2-5.5"	30-120mm/1.2-4.7"	±0.001mm	0.001mm

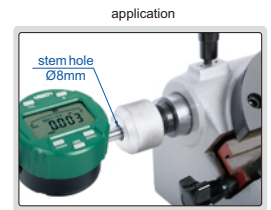

OUTSIDE DIAMETER MEASURING STAND

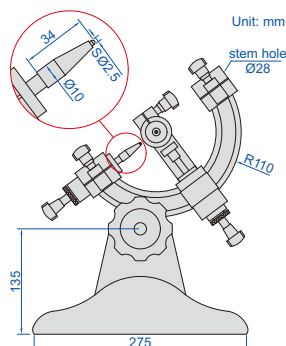

6847-50

- To measure diameter and roundness of cylinders and steel balls
- Supplied with measuring base (code **6847-A100**)
- Optional accessory: Ø28mm/Ø8mm bush (code **6843-B8**), 0.001mm digital/dial indicators, high precision digital indicators (code **2140-6**, **2140-6WL**), gage blocks (**4101** series, for zero setting of cylinders), custom plug gages (for zero setting of cylinders), ceramic standard balls (**4190** series, for zero setting of steel balls)

Code	Range of outside diameter	Accuracy	Repeatability
6847-50	1.5-50mm/0.06-2"	±0.001mm	0.0005mm

Measuring base

Code	Diameter	Remark
6847-A10	10mm	optional
6847-A20	20mm	optional
6847-A30	30mm	optional
6847-A40	40mm	optional
6847-A50	50mm	optional
6847-A60	60mm	optional
6847-A70	70mm	optional
6847-A75	75mm	optional
6847-A80	80mm	optional
6847-A90	90mm	optional
6847-A100	100mm	included

Ø28mm/Ø8mm bush (optional)
Code
6843-B8

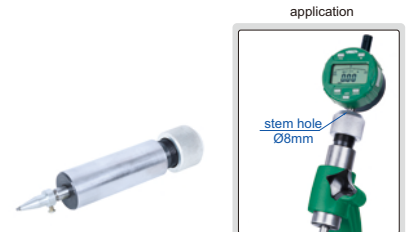



Digital Micrometers/Snap Gages
Page 41-42



Digital Micrometers
Page 42-43



Outside Micrometers
Page 44-45



Large Outside Micrometers
Page 45-46



Indicating Micrometers
Page 46



Micrometers With Dial Indicator
Page 46



Groove Micrometers
Page 47



3-wires
Page 47



Screw Thread Micrometers
Page 47-48



Gear Tooth Micrometers
Page 48



Point Micrometers
Page 48



Blade Micrometers
Page 49



Crimp Height Micrometers
Page 49



Spline Micrometers
Page 49



Tube Micrometers
Page 49



Caliper Type Micrometers
Page 50

06

MICROMETERS



Jaw Type Micrometers
Page 50



Disk Micrometers
Page 50-51



Sheet Metal Micrometers
Page 51



Wire Micrometers
Page 52



Micrometer Stands
Page 52



Micrometer Heads
Page 52

HIGH PRECISION DIGITAL MICROMETERS/SNAP GAGES

NON-ROTATING SPINDLE

ONE TURN OF SLEEVE MAKES 5MM SPINDLE FEED, PRESS THE FORK, THE SPINDLE RETRACTS 3MM

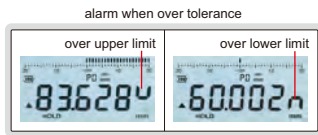

3359-25

ATTENTION: RECHARGEABLE BATTERY, FOR 24 HOURS CONTINUOUS WORKING

ABSOLUTE ENCODER, THE ORIGINAL DATA REMAINS AFTER POWER OFF

MEASUREMENT ACCURACY IS NOT AFFECTED BY THE USE OF SLEEVE

DATA OUTPUT

IP65 WATERPROOF

INSPECTION CERTIFICATE

- Absolute encoder, the original data remains after power off
- Accuracy: $\pm 0.5\mu\text{m}$, repeatability: $0.3\mu\text{m}$
- Resolution: $0.0001\text{mm}/0.00001''$
- One turn of sleeve makes 10mm spindle feed
- Measurement accuracy is not affected by the use of sleeve
- Press the fork, the spindle retracts 3mm
- Carbide spindle and anvil
- Measuring force 5-10N
- Button function: data output, tolerance, data preset, data hold, measuring direction change, max./min./TIR, power off time, on/off, zero, mm/inch
- Power: rechargeable battery, for 24 hours continuous working

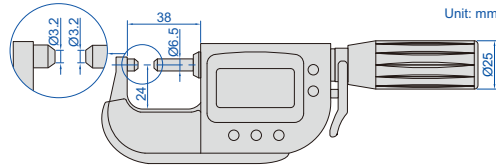

With data interface

Optional accessory:
wireless transmitter, code 7315-3350 receiver is needed
data output cable (keyboard format), code 7302-3350

Code	Range	Measuring faces	
		flatness	parallelism
3359-25*	0-25mm/0-1"	$0.3\mu\text{m}$	$0.6\mu\text{m}$

*Supplied with manufacturer inspection certificate

Built-in wireless

Optional accessory:
receiver (keyboard format, connect up to 15 digital indicators), code 2134-R1
receiver (serial port format, connect up to 15 digital indicators), code 2134-R2

Code	Range	Measuring faces	
		flatness	parallelism
3359-25WL*	0-25mm/0-1"	$0.3\mu\text{m}$	$0.6\mu\text{m}$

receiver 2134-R1, 2134-R2 (optional)



DIGITAL MICROMETERS/SNAP GAGES (ADVANCED TYPE)

NON-ROTATING SPINDLE

ONE TURN OF SLEEVE MAKES 5MM SPINDLE FEED, PRESS THE FORK, THE SPINDLE RETRACTS 3MM

- Absolute encoder, the original data remains after power off
- Adjustable resolution: $0.0002\text{mm}/0.00001''$; $0.001\text{mm}/0.00005''$; $0.01\text{mm}/0.0005''$
- One turn of sleeve makes 5mm spindle feed
- Measurement accuracy is not affected by the use of sleeve
- Press the fork, the spindle retracts 3mm
- Linear ball bearings for ten million times use
- Carbide spindle and anvil
- Measuring force 7-10N
Customizable measuring force range 2-12N
Attention: small measuring force will reduce the dustproof and waterproof level
- Button function: data output, tolerance, data preset, data hold, measuring direction change, max./min./TIR, power off time, on/off, zero, mm/inch, adjust resolution
- Supplied with gage blocks for zero setting (except 0-25mm/0-1")
- Power: rechargeable battery, for 24 hours continuous working



3350-25

ATTENTION: RECHARGEABLE BATTERY, FOR 24 HOURS CONTINUOUS WORKING

ABSOLUTE ENCODER, THE ORIGINAL DATA REMAINS AFTER POWER OFF

MEASUREMENT ACCURACY IS NOT AFFECTED BY THE USE OF SLEEVE

DATA OUTPUT

IP65 WATERPROOF



INSPECTION CERTIFICATE

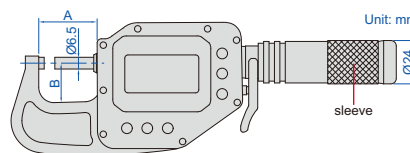

With data interface

Optional accessory:
wireless transmitter, code 7315-3350 receiver is needed
data output cable (keyboard format), code 7302-3350

Code	Range	Accuracy	Repeatability	Measuring faces		A	B
				flatness	parallelism		
3350-25*	0-25mm/0-1"	$1.4\mu\text{m}$	$0.6\mu\text{m}$	$0.5\mu\text{m}$	$1\mu\text{m}$	38mm	24mm
3350-50*	25-50mm/1-2"	$1.6\mu\text{m}$	$1\mu\text{m}$	$0.5\mu\text{m}$	$1\mu\text{m}$	63mm	28mm
3350-75*	50-75mm/2-3"	$1.8\mu\text{m}$	$1\mu\text{m}$	$0.5\mu\text{m}$	$1\mu\text{m}$	88mm	45mm
3350-100*	75-100mm/3-3.95"	$2\mu\text{m}$	$1\mu\text{m}$	$0.5\mu\text{m}$	$1\mu\text{m}$	113mm	57mm

Built-in wireless

Optional accessory:
receiver (keyboard format, connect up to 15 digital indicators), code 2134-R1
receiver (serial port format, connect up to 15 digital indicators), code 2134-R2

Code	Range	Accuracy	Repeatability	Measuring faces		A	B
				flatness	parallelism		
3350-25WL*	0-25mm/0-1"	$1.4\mu\text{m}$	$0.6\mu\text{m}$	$0.5\mu\text{m}$	$1\mu\text{m}$	38mm	24mm
3350-50WL*	25-50mm/1-2"	$1.6\mu\text{m}$	$1\mu\text{m}$	$0.5\mu\text{m}$	$1\mu\text{m}$	63mm	28mm
3350-75WL*	50-75mm/2-3"	$1.8\mu\text{m}$	$1\mu\text{m}$	$0.5\mu\text{m}$	$1\mu\text{m}$	88mm	45mm
3350-100WL*	75-100mm/3-3.95"	$2\mu\text{m}$	$1\mu\text{m}$	$0.5\mu\text{m}$	$1\mu\text{m}$	113mm	57mm

*Supplied with manufacturer inspection certificate

alarm when over tolerance

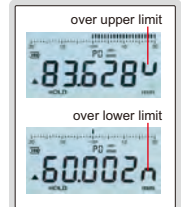

receiver 2134-R1, 2134-R2 (optional)



DIGITAL MICROMETERS/SNAP GAGES

DATA OUTPUT

IP65 WATERPROOF

MEASUREMENT ACCURACY IS NOT AFFECTED BY THE USE OF SLEEVE

ATTENTION: RECHARGEABLE BATTERY, FOR 24 HOURS CONTINUOUS WORKING



NON-ROTATING SPINDLE

ONE TURN OF SLEEVE MAKES 10MM SPINDLE FEED, PRESS THE FORK, THE SPINDLE RETRACTS 3MM

ABSOLUTE ENCODER, THE ORIGINAL DATA REMAINS AFTER POWER OFF

POPULAR MODEL

- Absolute encoder, the original data remains after power off
- Resolution: 0.001mm/0.00005"
- One turn of sleeve makes 10mm spindle feed
- Measurement accuracy is not affected by the use of sleeve
- Press the fork, the spindle retracts 3mm
- Carbide spindle and anvil
- Measuring force 5-10N
- Button function: data output, tolerance, data preset, data hold, measuring direction change, max./min./TIR, power off time, on/off, zero, mm/inch
- Supplied with gage blocks for zero setting (except 0-25mm/0-1")
- Power: rechargeable battery, for 24 hours continuous working



3358-25

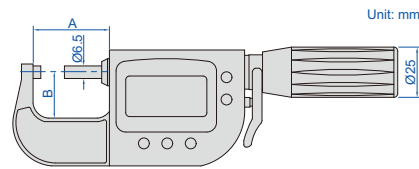

With data interface

Optional accessory:
wireless transmitter, code 7315-3350 receiver is needed
data output cable (keyboard format), code 7302-3350

Code	Range	Accuracy	Repeatability	Measuring faces		A	B
				flatness	parallelism		
3358-25*	0-25mm/0-1"	2µm	1µm	0.5µm	1.2µm	38mm	24mm
3358-50*	25-50mm/1-2"	2µm	1µm	0.5µm	1.2µm	64mm	32.5mm

receiver 2134-R1, 2134-R2 (optional)



Built-in wireless

Optional accessory:
wireless receiver (keyboard format, connect up to 15 digital indicators), code 2134-R1
wireless receiver (serial port format, connect up to 15 digital indicators), code 2134-R2

Code	Range	Accuracy	Repeatability	Measuring faces		A	B
				flatness	parallelism		
3358-25WL*	0-25mm/0-1"	2µm	1µm	0.5µm	1.2µm	38mm	24mm
3358-50WL*	25-50mm/1-2"	2µm	1µm	0.5µm	1.2µm	64mm	32.5mm

alarm when over tolerance

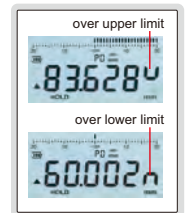

*Supplied with manufacturer inspection certificate

WATERPROOF DIGITAL OUTSIDE MICROMETERS (WITH DATA OUTPUT)



DATA OUTPUT

IP65 WATERPROOF

POPULAR MODEL

- Resolution 0.001mm/0.00005"
- IP65 dust/waterproof
- Button function: on/off, set, mm/inch, data transmit
- Data output
- Automatic power off
- Carbide measuring faces
- Ratchet stop
- Supplied with spherical anvil
- Setting standards are included (except 0-25mm/0-1")
- Optional accessory: data output cable (code 7315-31 receiver is needed, 7302-30)

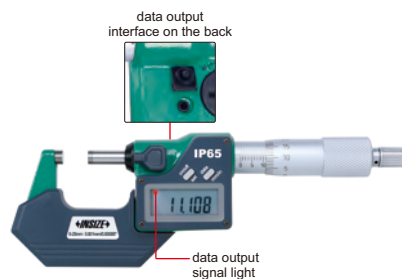

3101-25A

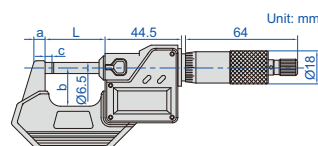

Code	Range	Accuracy	L	a	b	c
3101-25A*	0-25mm/0-1"	±2µm	34.5mm	6mm	25mm	3mm
3101-50A*	25-50mm/1-2"	±2µm	59.5mm	8mm	32mm	3mm
3101-75A*	50-75mm/2-3"	±3µm	84.5mm	8mm	44.5mm	3mm
3101-100A*	75-100mm/3-4"	±3µm	109.5mm	8mm	57mm	3mm

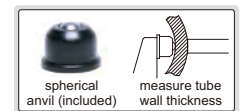

*Supplied with manufacturer inspection certificate

WATERPROOF DIGITAL OUTSIDE MICROMETERS (WITHOUT DATA OUTPUT)

IP65
WATERPROOF

ATTENTION: NO DATA OUTPUT



- Resolution 0.001mm/0.00005"
- IP65 dust/waterproof
- Button function: on/off, set, mm/inch, ABS/INC
- No data output
- Automatic power off
- Carbide measuring faces
- Ratchet stop
- Supplied with spherical anvil
- Setting standards are included (except 0-25mm/0-1")



3108-25A

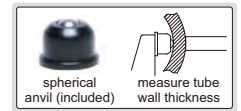
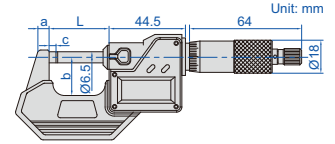

Code	Range	Accuracy	L	a	b	c
3108-25A*	0-25mm/0-1"	±2µm	34.5mm	6mm	25mm	3mm
3108-50A*	25-50mm/1-2"	±2µm	59.5mm	8mm	32mm	3mm
3108-75A*	50-75mm/2-3"	±3µm	84.5mm	8mm	44.5mm	3mm
3108-100A*	75-100mm/3-4"	±3µm	109.5mm	8mm	57mm	3mm
3108-125A	100-125mm/4-5"	±3µm	135mm	10mm	70mm	3mm
3108-150A	125-150mm/5-6"	±3µm	160.5mm	10mm	82mm	3mm
3108-175A	150-175mm/6-7"	±4µm	186mm	12mm	94.5mm	5.5mm
3108-200A	175-200mm/7-8"	±4µm	211.5mm	12mm	107mm	5.5mm

*Supplied with manufacturer inspection certificate

DIGITAL OUTSIDE MICROMETERS (BASIC TYPE, WITHOUT DATA OUTPUT)



ATTENTION: NO DATA OUTPUT

POPULAR MODEL

- Resolution 0.001mm/0.00005"
- Button function: on/off, set, mm/inch, ABS/INC
- No data output
- Automatic power off
- Carbide measuring faces
- Friction thimble
- Supplied with spherical anvil
- Setting standards are included (except 0-25mm/0-1")



3109-25A

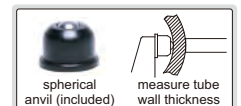
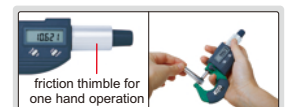
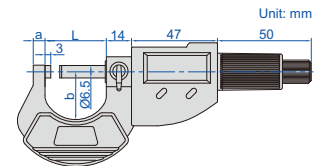

Code	Range	Accuracy	L	a	b
3109-25A*	0-25mm/0-1"	±2µm	32mm	6mm	28mm
3109-50A*	25-50mm/1-2"	±2µm	57mm	8mm	37mm
3109-75A*	50-75mm/2-3"	±3µm	82mm	8mm	50mm
3109-100A*	75-100mm/3-4"	±3µm	107mm	10mm	61mm
3109-125A	100-125mm/4-5"	±3µm	132mm	10mm	73mm
3109-150A	125-150mm/5-6"	±3µm	157mm	10mm	85mm
3109-175A	150-175mm/6-7"	±4µm	182mm	20mm	104mm
3109-200A	175-200mm/7-8"	±4µm	207mm	20mm	117mm

*Supplied with manufacturer inspection certificate

OUTSIDE MICROMETERS

- Graduation: 0.01mm
- Carbide measuring faces
- Meet DIN863-1
- Ratchet stop
- Supplied with setting standards (except 0-25mm)

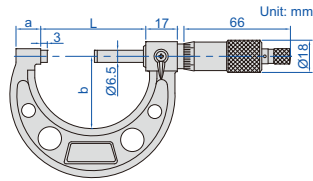

3203-25A



3203-50A



3203-1004A

Individual

Code	Range	Accuracy	L	a	b
3203-25A*	0-25mm	±2µm	32mm	9mm	28mm
3203-50A*	25-50mm	±2µm	57mm	14mm	38mm
3203-75A*	50-75mm	±2µm	82mm	15mm	49mm
3203-100A*	75-100mm	±3µm	107mm	15mm	60mm
3203-125A	100-125mm	±3µm	133mm	16.5mm	73mm
3203-150A	125-150mm	±3µm	158mm	16.5mm	85mm
3203-175A	150-175mm	±4µm	183mm	19.4mm	104mm
3203-200A	175-200mm	±4µm	209mm	19.4mm	117mm
3203-225A	200-225mm	±4µm	234mm	19.4mm	130mm
3203-250A	225-250mm	±5µm	260mm	19.4mm	142mm
3203-275A	250-275mm	±5µm	285mm	19.4mm	155mm
3203-300A	275-300mm	±5µm	310mm	19.4mm	168mm

Set

Code	Range	Micrometers included	Packaging
3203-753A*	0-75mm	3203-25A, 3203-50A, 3203-75A	blow mould case
3203-1004A*	0-100mm	3203-25A, 3203-50A, 3203-75A, 3203-100A	blow mould case
3203-1506A	0-150mm	3203-25A, 3203-50A, 3203-75A, 3203-100A, 3203-125A, 3203-150A	blow mould case

*Supplied with manufacturer inspection certificate

1µm GRADUATION OUTSIDE MICROMETERS

- Graduation: 0.001mm
- Carbide measuring faces
- Meet DIN863-1
- Ratchet stop
- Supplied with setting standards (except 0-25mm)



3210-25A

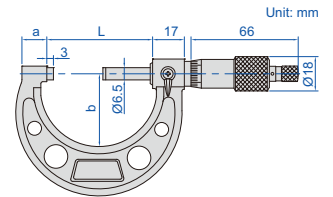

Code	Range	Accuracy	L	a	b
3210-25A*	0-25mm	4µm	32mm	9mm	28mm
3210-50A*	25-50mm	4µm	57mm	14mm	38mm
3210-75A*	50-75mm	5µm	82mm	15mm	49mm
3210-100A*	75-100mm	5µm	107mm	15mm	60mm

*Supplied with manufacturer inspection certificate

OUTSIDE MICROMETERS WITH COUNTER

- Counter resolution: 0.01mm
- Thimble graduation: 0.01mm
- Carbide measuring faces
- Meet DIN863-1
- Ratchet stop
- Supplied with setting standards (except 0-25mm)



3400-25

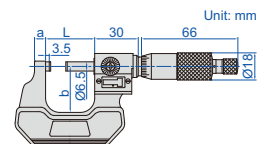

Code	Range	Accuracy	L	a	b
3400-25*	0-25mm	4µm	32mm	6mm	26mm
3400-50*	25-50mm	4µm	57mm	8mm	32mm
3400-75*	50-75mm	5µm	82mm	8mm	44.5mm
3400-100*	75-100mm	5µm	107mm	8mm	57mm

*Supplied with manufacturer inspection certificate

OUTSIDE MICROMETER FOR LEFT OR RIGHT HANDERS

- Graduation 0.01mm
- Graduations on two sides
- Ratchet stop
- Carbide measuring faces
- Meet DIN863-1

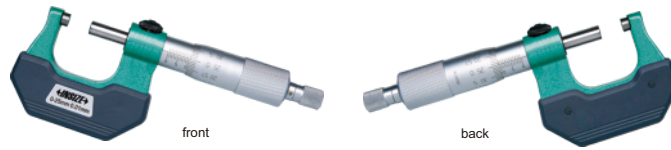

3236-25B

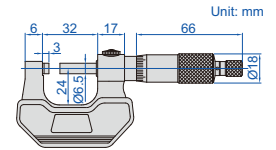

Code	Range	Accuracy
3236-25B	0-25mm	4µm

OUTSIDE MICROMETERS WITH EXTENSION ANVIL COLLAR

- Graduation: 0.01mm
- Adjust collars for different measuring ranges
- Ratchet stop
- Carbide measuring faces
- Supplied with setting standards

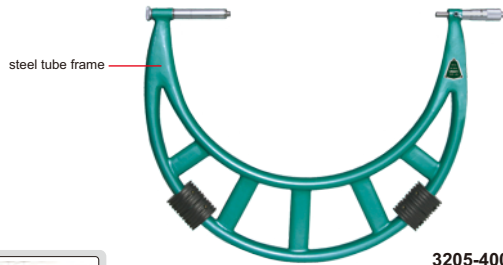

3205-400

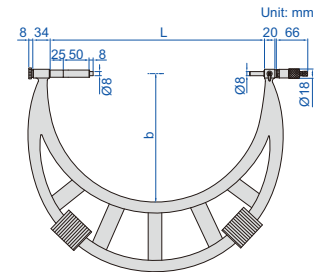

setting standard (included)



(mm)

Code	Range	Accuracy	L	b	Setting standard (included)
3205-400	300-400mm	11µm	410	250	325, 375
3205-500	400-500mm	13µm	510	295	425, 475
3205-600	500-600mm	14µm	610	345	525, 575
3205-700	600-700mm	16µm	710	395	625, 675
3205-800	700-800mm	18µm	810	445	725, 775
3205-900	800-900mm	20µm	910	495	825, 875
3205-1000	900-1000mm	22µm	1010	545	925, 975

adjust collars for different measuring ranges



OUTSIDE MICROMETERS WITH INTERCHANGEABLE ANVILS

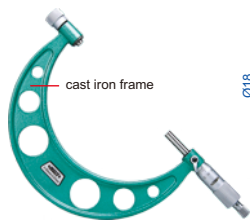

3206-150A

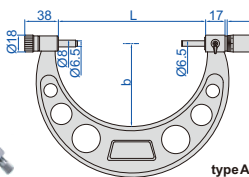

type A

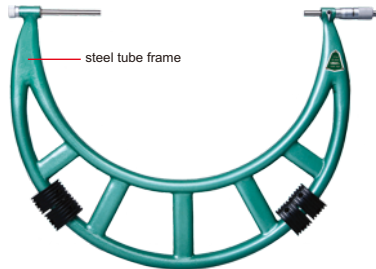

3206-400

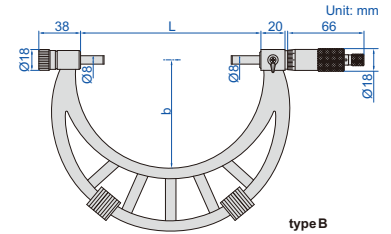

type B

- Graduation: 0.01mm
- Ratchet stop
- Meet DIN863-3
- Carbide measuring faces
- Supplied with setting standards

setting standard (included)

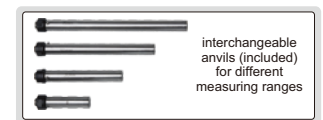

Code	Range	Type	Accuracy	L	b	Setting standard (included)
3206-150A	0-150mm	A	6µm	158	82	25, 50, 75, 100, 125
3206-200A	100-200mm	A	7µm	208	114	100, 125, 150, 175
3206-300A	150-300mm	A	9µm	308	165	150, 175, 200, 225, 250, 275
3206-400	300-400mm	B	11µm	409	224	325, 375
3206-500	400-500mm	B	13µm	509	275	425, 475
3206-600	500-600mm	B	14µm	609	321	525, 575

DIGITAL OUTSIDE MICROMETERS WITH INTERCHANGEABLE ANVILS

IP65
WATERPROOF

DATA
OUTPUT

- Resolution 0.001mm/0.0001" (resolution of **3506-150A** is 0.001mm/0.00005")
- IP65 dust/waterproof
- Button function: on/off, set, mm/inch, data transmit
- Data output
- Automatic power off
- Ratchet stop
- Carbide measuring faces
- Supplied with setting standards
- Optional accessory: data output cable (code **7315-31** receiver is needed, **7302-30**)

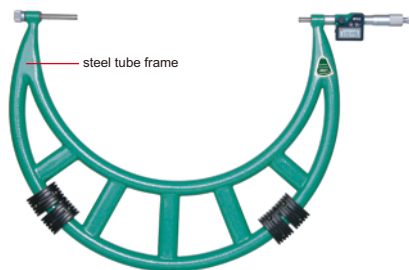

3506-400A

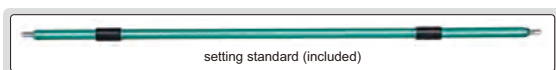
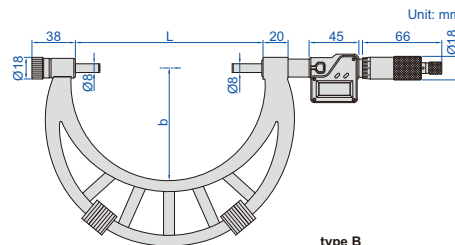
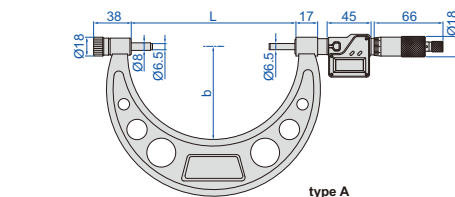

Code	Range	Type	Accuracy	L	b	Setting standard (included)
3506-150A	0-150mm/0-6"	A	±6µm	155	82	25, 50, 75, 100, 125
3506-300A	150-300mm/6-12"	A	±8µm	305	165	150, 175, 200, 225, 250, 275
3506-400A	300-400mm/12-16"	B	±9µm	405	224	325, 375
3506-500A	400-500mm/16-20"	B	±11µm	505	275	425, 475

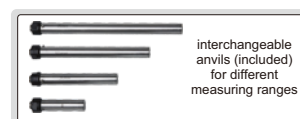

INDICATING MICROMETERS

ATTENTION: SETTING STANDARDS ARE NOT INCLUDED



3332-25

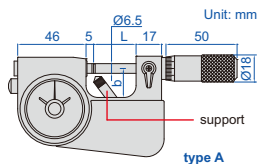

3332-25B

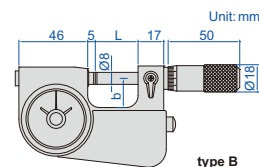

- Meet DIN863-3
- Micrometer head graduation: 0.002mm
- Dial indicator: range ±0.04mm, graduation 0.001mm, accuracy 0.001mm
- Carbide measuring faces
- Optional accessory: gage blocks grade 0 (**4101-A** series), for zero setting

Code	Micrometer head range	Micrometer head accuracy	Type	L	b	Remark
3332-25	0-25mm	4µm	A	28.5mm	19mm	with support
3332-50	25-50mm	4µm	A	53.5mm	30mm	with support
3332-75	50-75mm	5µm	A	78.5mm	45mm	without support
3332-100	75-100mm	5µm	A	103.5mm	57mm	without support
3332-25B	0-25mm	4µm	B	28.5mm	19mm	without support

MICROMETERS WITH DIAL INDICATOR

ATTENTION: NOT SUITABLE FOR 0.001MM DIAL INDICATORS

- Meet DIN863-3
- Micrometer head graduation 0.01mm
- Anvil retracting range: 8mm
- Carbide measuring faces
- Supplied with setting standards (except 0-25mm)
- Optional accessory: dial indicators (graduation 0.01mm), digital indicators (resolution 0.01mm/0.0005")



3331-25A

Code	Micrometer head range	Micrometer head accuracy	L	b
3331-25A	0-25mm	4µm	67mm	38mm
3331-50A	25-50mm	4µm	92.4mm	50mm
3331-75A	50-75mm	5µm	117.6mm	62mm
3331-100A	75-100mm	5µm	143mm	70mm

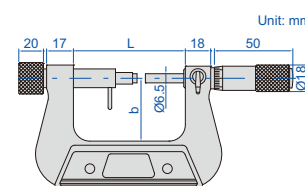

GROOVE MICROMETERS

- Measure width of grooves inside bores
- Graduation 0.01mm
- Two graduations for inside and outside measurements
- Non-rotating spindle
- Two-directional ratchet stop



3287-50B

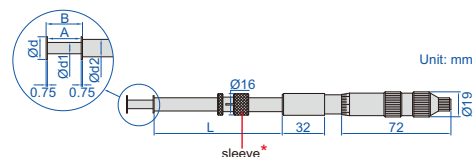

Unit: mm

Code	Range (outside A)	Range (inside B)	Accuracy	L	Ød	Ød1	Ød2
3287-25B	0-25mm	1.6-26.5mm	10µm	120	13	6.5	10
3287-50B	25-50mm	26.5-51.5mm	10µm	120	13	6.5	10
3287-75B	50-75mm	51.5-76.5mm	10µm	120	13	6.5	10
3287-100B	75-100mm	76.5-101.5mm	10µm	120	13	6.5	10
3287-251B *	0-25mm	1.6-26.5mm	10µm	90	6.5	3	5

(mm)

*3287-251B does not have sleeve

measure width of keyway

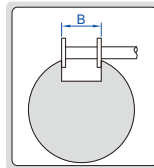

measure position of groove

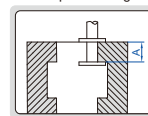

measure width of groove

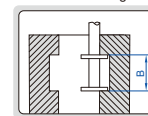

3-WIRES

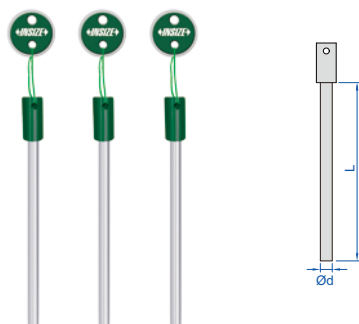

7394-76A

- Length L=45mm
- Ød≤0.3mm, made of alloy steel, hardness HRC60;
Ød>0.3mm, made of carbide, hardness HRA90
- Diameter accuracy: ±0.5µm
- Cylindricity: ±0.5µm
- Supplied with manufacturer inspection certificate



CUSTOMIZABLE PIN GAGE DIAMETER Ød

Code	Diameter (Ød)	Applicable pitch
7394-64A *	0.290mm	0.5mm
7394-65A	0.335mm	0.6mm
7394-66A	0.390mm	0.7mm
7394-67A	0.455mm	0.75mm, 0.8mm
7394-68A	0.530mm	0.9mm
7394-69A	0.620mm	1.0mm
7394-70A	0.725mm	1.25mm
7394-71A	0.895mm	1.5mm
7394-72A	1.100mm	1.75mm, 2.0mm
7394-73A	1.350mm	2.5mm
7394-74A	1.650mm	3.0mm
7394-75A	2.050mm	3.5mm
7394-76A	2.550mm	4mm, 4.5mm
7394-77A	3.200mm	5mm, 5.5mm, 6mm

* Made of alloy steel

SCREW THREAD MICROMETERS

- Graduation: 0.01mm
- Measure pitch diameter of screw threads
- Non-rotating spindle
- Ratchet stop
- Supplied with 60° setting standards (except 0-25mm)
- 6 pairs of measuring tips (included): metric and unified thread (60° thread angle)
0.4-0.5mm/64-48TPI, 0.6-0.9mm/44-28TPI, 1-1.75mm/24-14TPI, 2-3mm/13-9TPI, 3.5-5mm/8-5TPI, 5.5-7mm/4.5-3.5TPI
- Optional accessory: 55° setting standards



3281-S25
(measuring tips are included)

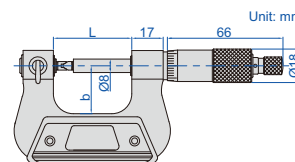

Unit: mm

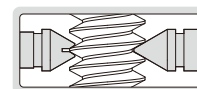

accuracy of micrometers with tips (mm)

Pitch	Range			
	0-25	25-50	50-75	75-100
0.4~0.5	±0.01	-	-	-
0.6~0.8	±0.01	±0.013	-	-
1~1.25	±0.012	±0.015	±0.017	±0.017
1.5~2.0	±0.014	±0.017	±0.019	±0.019
2.5~3.5	±0.016	±0.019	±0.021	±0.021
4.0~7.0	-	±0.021	±0.023	±0.023

Code	Range	L	b	55° setting standard (optional)
3281-S25	0-25mm	42mm	26mm	-
3281-S50	25-50mm	67mm	38mm	3281-SP1
3281-S75	50-75mm	92mm	50mm	3281-SP2
3281-S100	75-100mm	117.6mm	62mm	3281-SP3

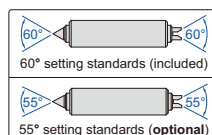

DIGITAL SCREW THREAD MICROMETERS

NON-ROTATING SPINDLE

DATA OUTPUT

- Measure pitch diameter of screw threads
- Resolution 0.001mm/0.00005"
- Button function: on/off, set, mm/inch, data transmit
- Data output
- Automatic power off
- Non-rotating spindle
- Ratchet stop
- Supplied with 60° setting standards (except 0-25mm/0-1")
- 6 pairs of measuring tips (included): metric and unified thread (60° thread angle) 0.4-0.5mm/64-48TPI, 0.6-0.9mm/44-28TPI, 1-1.75mm/24-14TPI, 2-3mm/13-9TPI, 3.5-5mm/8-5TPI, 5.5-7mm/4.5-3.5TPI
- Optional accessory: 55° setting standards, data output cable (code 7315-31 receiver is needed, 7302-30)



3581-S25
(measuring tips are included)

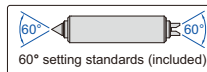
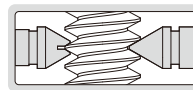
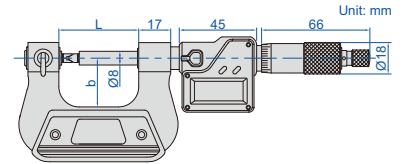

accuracy of micrometers with tips (mm)

Code	Range	L	b	55° setting standard (optional)
3581-S25	0-25mm/0-1"	42mm	26mm	-
3581-S50	25-50mm/1-2"	67mm	38mm	3281-SP1
3581-S75	50-75mm/2-3"	92mm	50mm	3281-SP2
3581-S100	75-100mm/3-4"	117.6mm	62mm	3281-SP3

Pitch	Range			
	0-25	25-50	50-75	75-100
0.4~0.5	±0.01	-	-	-
0.6~0.8	±0.01	±0.013	-	-
1~1.25	±0.012	±0.015	±0.017	±0.017
1.5~2.0	±0.014	±0.017	±0.019	±0.019
2.5~3.5	±0.016	±0.019	±0.021	±0.021
4.0~7.0	-	±0.021	±0.023	±0.023

GEAR TOOTH MICROMETERS

- Meet DIN863-3
- Measure over-pin diameter of gears
- Graduation 0.01mm
- Ratchet stop
- Supplied with setting standards (except 0-25mm)
- Optional accessory: ball tips (code 7391)



3291-25

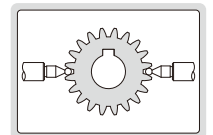
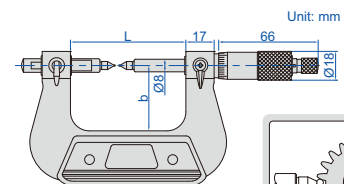

Code	Range	Accuracy	L	b
3291-25	0-25mm	4µm	67mm	38mm
3291-50	25-50mm	4µm	92.4mm	50mm
3291-75	50-75mm	5µm	117.6mm	62mm
3291-100	75-100mm	5µm	143mm	70mm

BALL TIPS FOR GEAR TOOTH MICROMETERS



7391-T5

- Supplied in pair
- Suitable for 3291, 3591 series micrometers

Code	Ball dia. (D)
7391-T2	SØ1.5mm
7391-T3	SØ2.0mm
7391-T4	SØ2.5mm
7391-T5	SØ3.0mm
7391-T6	SØ3.5mm
7391-T7	SØ4.0mm
7391-T8	SØ4.5mm
7391-T9	SØ5.0mm
7391-T10	SØ6.0mm

POINT MICROMETERS



3230-25A

- Graduation 0.01mm
- Measure the web thickness of drills, small grooves and keyways
- Ratchet stop
- Carbide tips
- Supplied with setting standards (except 0-25mm)

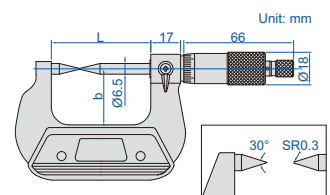

Code	Range	Accuracy	L	b
3230-25A	0-25mm	4µm	57mm	32mm
3230-50A	25-50mm	4µm	82mm	44.5mm
3230-75A	50-75mm	5µm	107mm	57mm
3230-100A	75-100mm	5µm	132.6mm	69.5mm

BLADE MICROMETERS

NON-ROTATING SPINDLE

- Meet DIN863-3
- Measure the groove diameter of shafts and keyways
- Graduation: 0.01mm
- Non-rotating spindle
- Ratchet stop
- Supplied with setting standards (except 0-25mm)

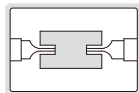

3232-25A

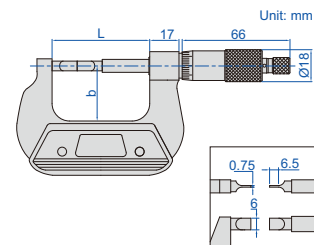

Code	Range	Accuracy	L	b
3232-25A	0-25mm	4µm	57mm	32mm
3232-50A	25-50mm	4µm	82mm	44.5mm
3232-75A	50-75mm	5µm	107mm	57mm
3232-100A	75-100mm	5µm	132.6mm	69.5mm

CRIMP HEIGHT MICROMETER

- Measure the height of crimp contact
- Graduation 0.01mm
- Ratchet stop



3266-25BA

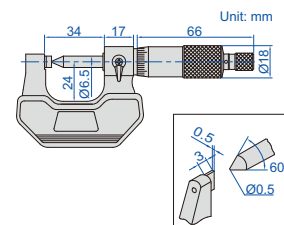

Code	Range	Accuracy
3266-25BA	0-25mm	4µm

SPLINE MICROMETER

- Meet DIN863-3
- Measure splined shafts, slots and keyways
- Graduation 0.01mm
- Ratchet stop
- Carbide measuring faces

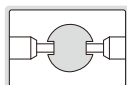

3233-25BA

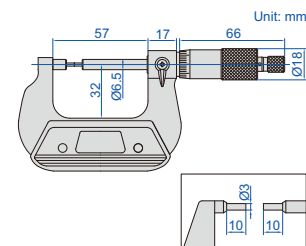

Code	Range	Accuracy
3233-25BA	0-25mm	4µm

CYLINDRICAL ANVIL TUBE MICROMETERS



3261-25A

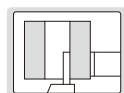

- Measure wall thickness of tubes
- Graduation 0.01mm
- Accuracy: 6µm
- Ratchet stop
- Carbide spindle tip

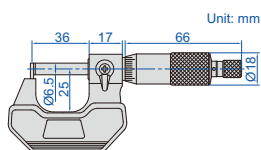

Code	Range	Type
3261-25A	0-25mm	A
3261-25BA	0-25mm	B

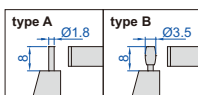

SPHERICAL ANVIL TUBE MICROMETER



3260-25SA

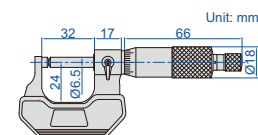
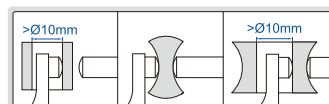

- Meet DIN863-3
- Measure wall thickness of tubes
- Graduation 0.01mm
- Ratchet stop
- Carbide measuring faces

Code	Range	Accuracy
3260-25SA	0-25mm	4µm

CALIPER TYPE MICROMETER

- Graduation 0.01mm
- Non-rotating spindle
- Ratchet stop
- Carbide measuring faces

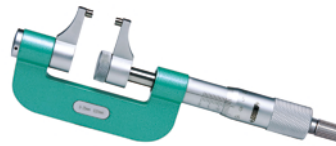
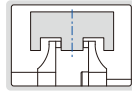

3238-25

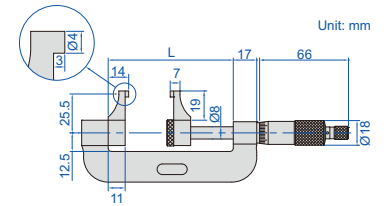

Code	Range	Accuracy	L
3238-25	0-25mm	10µm	56mm

JAW TYPE MICROMETER

- Graduation 0.01mm
- Non-rotating spindle
- Ratchet stop

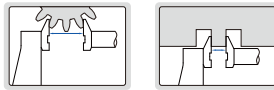

3283-25A

NON-ROTATING SPINDLE

Code	Range	Accuracy
3283-25A	0-25mm	4µm

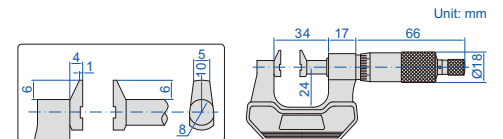

DISK MICROMETERS

- Parallelism: 5µm
- Measure root tangent length of gear
- Graduation 0.01mm
- Ratchet stop
- Supplied with setting standards



3282-25

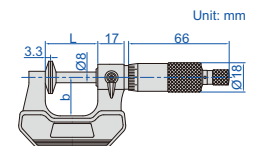

Code	Range	Accuracy	L	b
3282-25	0-25mm	4µm	34mm	24mm
3282-50	25-50mm	4µm	59mm	32mm
3282-75	50-75mm	5µm	85mm	45mm
3282-100	75-100mm	5µm	110mm	57mm

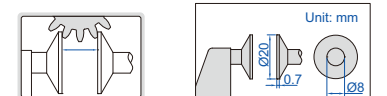

DIGITAL NON-ROTATING SPINDLE DISK MICROMETERS

DATA OUTPUT

NON-ROTATING SPINDLE

- Measure root tangent length of gear
- Resolution 0.001mm/0.00005"
- Non-rotating spindle
- Button function: on/off, set, mm/inch, data transmit
- Data output
- Automatic power off
- Ratchet stop
- Supplied with setting standards
- Optional accessory: data output cable (code 7315-31 receiver is needed, 7302-30)



3594-25A

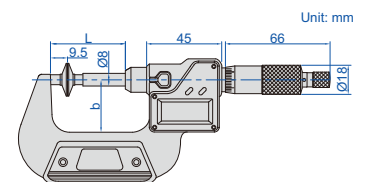

Code	Range	Accuracy	Parallelism	L	b
3594-25A	0-25mm/0-1"	±4µm	5µm	43mm	32mm
3594-50A	25-50mm/1-2"	±4µm	5µm	68mm	44.5mm
3594-75A	50-75mm/2-3"	±5µm	5µm	93mm	57mm
3594-100A	75-100mm/3-4"	±5µm	5µm	118.5mm	70mm

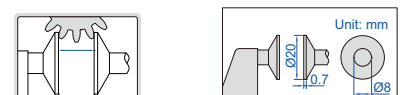

DIGITAL DISK MICROMETERS/SNAP GAGES

DATA OUTPUT

NON-ROTATING SPINDLE

ONE TURN OF SLEEVE MAKES 5MM SPINDLE FEED, PRESS THE FORK, THE SPINDLE RETRACTS 3MM

ABSOLUTE ENCODER, THE ORIGINAL DATA REMAINS AFTER POWER OFF

MEASUREMENT ACCURACY IS NOT AFFECTED BY THE USE OF SLEEVE

ATTENTION: RECHARGEABLE BATTERY, FOR 24 HOURS CONTINUOUS WORKING

IP65 WATERPROOF



- Measure root tangent length of gear
- Absolute encoder, the original data remains after power off
- Adjustable resolution: 0.0002mm/0.0001" 0.001mm/0.00005" 0.01mm/0.0005"
- One turn of sleeve makes 5mm spindle feed
- Measurement accuracy is not affected by the use of sleeve
- Press the fork, the spindle retracts 3mm
- Linear ball bearings for ten million times use
- Carbide spindle and anvil
- Measuring force 7-10N
Customizable measuring force range 2-12N
Attention: small measuring force will reduce the dustproof and waterproof level
- Button function: data output, tolerance, data preset, data hold, measuring direction change, max./min./TIR, power off time, on/off, zero, mm/inch, adjust resolution
- Supplied with gage blocks for zero setting
- Power: rechargeable battery, for 24 hours continuous working



3353-25

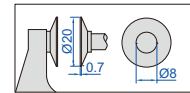
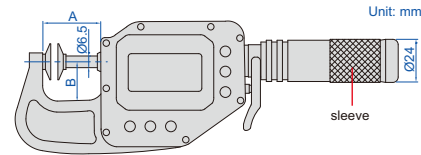

With data interface

Optional accessory:
wireless transmitter, code 7315-3350 receiver is needed
data output cable (keyboard format), code 7302-3350

Code	Range	Accuracy	Repeatability	Parallelism	A	B
3353-25 *	0-25mm/0-1"	4µm	1µm	4µm	38mm	24mm
3353-50 *	25-50mm/1-2"	4µm	1µm	4µm	63mm	25mm
3353-75 *	50-75mm/2-3"	5µm	1µm	5µm	88mm	42mm
3353-100 *	75-100mm/3-3.95"	5µm	1µm	5µm	113mm	56mm
3353-125 *	100-125mm/4-5"	6µm	2µm	6µm	128mm	62.5mm
3353-150 *	125-150mm/5-6"	6µm	2µm	6µm	153mm	75mm



Built-in wireless

Optional accessory:
wireless receiver (keyboard format, connect up to 15 digital indicators), code 2134-R1
wireless receiver (serial port format, connect up to 15 digital indicators), code 2134-R2

Code	Range	Accuracy	Repeatability	Parallelism	A	B
3353-25WL *	0-25mm/0-1"	4µm	1µm	4µm	38mm	24mm
3353-50WL *	25-50mm/1-2"	4µm	1µm	4µm	63mm	25mm
3353-75WL *	50-75mm/2-3"	5µm	1µm	5µm	88mm	42mm
3353-100WL *	75-100mm/3-3.95"	5µm	1µm	5µm	113mm	56mm
3353-125WL *	100-125mm/4-5"	6µm	2µm	6µm	128mm	62.5mm
3353-150WL *	125-150mm/5-6"	6µm	2µm	6µm	153mm	75mm

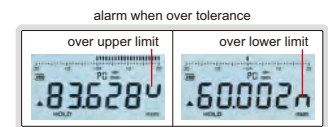

* Supplied with manufacturer inspection certificate

SHEET METAL MICROMETERS

- Meet DIN863-3
- Measure thickness of sheet metal, paper, plastic and rubber parts
- Graduation 0.01mm
- Ratchet stop
- Carbide measuring faces



3263-25A

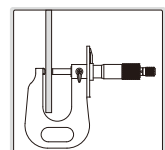
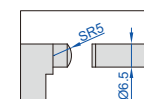
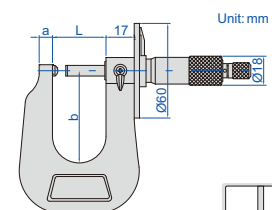

Code	Range	Accuracy	L	a	b
3263-15A	0-15mm	4µm	22mm	8mm	50mm
3263-25A	0-25mm	4µm	32mm	8mm	50mm

WIRE MICROMETER



3285-10

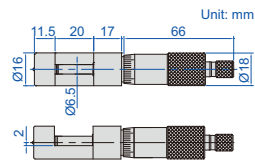

- Meet DIN863-3
- Measure diameter of wires and small balls
- Graduation 0.01mm
- Ratchet stop
- Carbide measuring faces

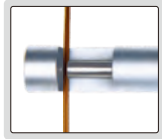

Code	Range	Accuracy
3285-10	0-10mm	4µm

MICROMETER STAND



6300

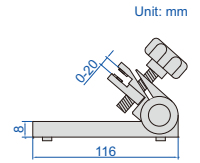

- Suitable for outside micrometers up to 100mm



Code
6300

MICROMETER STAND



6301

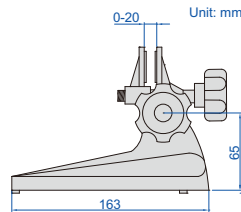

- Suitable for outside micrometers up to 100mm



Code
6301



6301-1

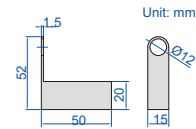

- Suitable for inside micrometers



Code	Description	Applicable products
6301-1	clamp for inside micrometers	all sizes of 3220 series



6301-2



- Suitable for three points internal micrometers

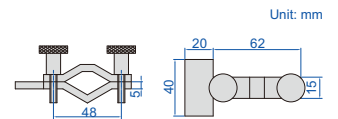

Code	Description	Applicable products
6301-2	clamp for three points internal micrometers	up to 100mm of 3127 and 3227 series

MICROMETER HEAD

- Meet DIN863-2
- Graduation 0.01mm
- Ratchet stop



6381-25W

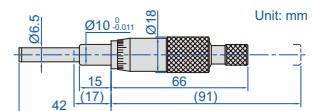

Code	Range	Stem	Spindle tip	Accuracy
6381-25W	0-25mm	plain	flat (carbide)	3µm

BORE DIAMETER, CIRCUMFERENCE MEASUREMENT

07

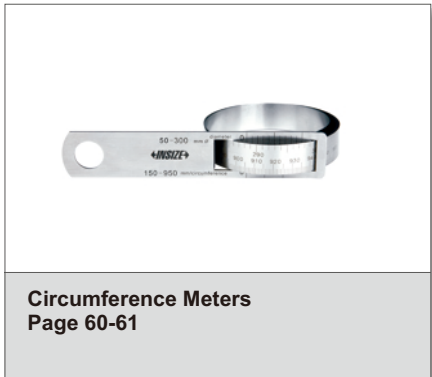
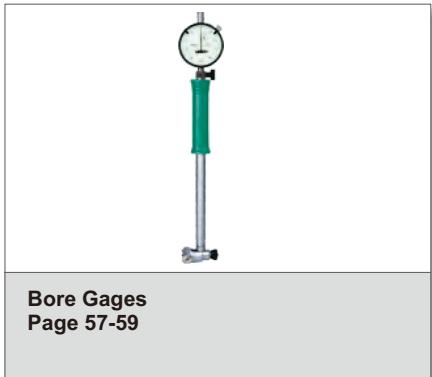

INSIDE MICROMETERS (ECONOMIC TYPE)

ATTENTION: LOW PARALLELISM OF TWO MEASURING FACES

- Graduation 0.01mm
- Ratchet stop
- Carbide measuring faces
- Optional accessory: setting ring (code **6312**), micrometer stand and clamp (code **6301** and **6301-1**)



3220-50

micrometer stand with clamp (optional)

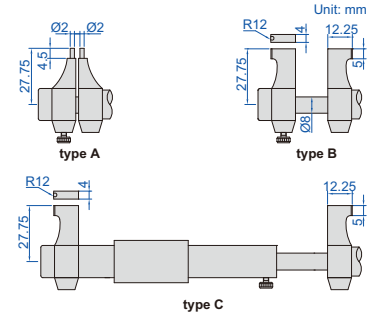

Code	Range	Type	Setting ring	Accuracy
3220-30	5-30mm	A	5mm (included)	7 μ m
3220-50	25-50mm	B	25mm (included)	8 μ m
3220-75	50-75mm	B	50mm (optional)	9 μ m
3220-100	75-100mm	C	75mm (optional)	10 μ m

DIGITAL INSIDE MICROMETERS (ECONOMIC TYPE)

DATA OUTPUT

ATTENTION: LOW PARALLELISM OF TWO MEASURING FACES

- Resolution 0.001mm/0.00005"
- Button function: on/off, set, mm/inch, data transmit
- Data output, automatic power off
- Ratchet stop
- Carbide measuring faces
- Optional accessory: data output cable (code **7315-31** receiver is needed, **7302-30**), setting ring (code **6312**)



3520-30

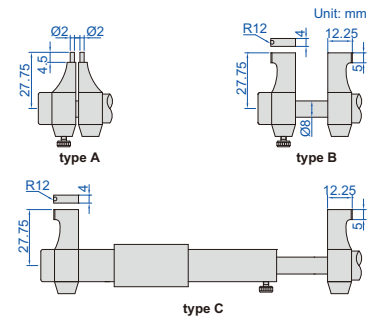

Code	Range	Type	Setting ring	Accuracy
3520-30	5-30mm/0.2-1.2"	A	5mm (included)	$\pm 5\mu$ m
3520-50	25-50mm/1-2"	B	25mm (included)	$\pm 6\mu$ m
3520-75	50-75mm/2-3"	B	50mm (optional)	$\pm 7\mu$ m
3520-100	75-100mm/3-4"	C	75mm (optional)	$\pm 8\mu$ m

TUBULAR INSIDE MICROMETERS



3221-200

- Graduation: 0.01mm
- Accuracy: $(6+L/50)\mu$ m
L=maximum measuring length (mm)
- Optional accessory: setting ring (code **6312**), gage block accessory (code **6881**), cylinder gage block (code **4001**), caliper/height gage checker (code **6884**)

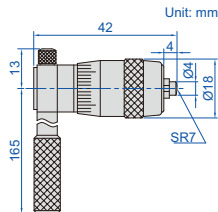

Code	Range	Travel of micrometer head	Extension rods
3221-32	25-32mm	7mm	—
3221-50	25-50mm	7mm	2 pcs
3221-63	50-63mm	13mm	—
3221-200	50-200mm	13mm	6 pcs
3221-300	50-300mm	13mm	10 pcs
3221-225	200-225mm	25mm	—
3221-500	200-500mm	25mm	3 pcs
3221-1000	200-1000mm	25mm	8 pcs

TUBULAR INSIDE MICROMETERS



3222-150

- Micrometer head: 50-63mm
- Travel of micrometer head: 13mm
- Graduation: 0.01mm
- Accuracy: $(3+n+L/50)\mu$ m
n=number of rods,
L=maximum measuring length (mm)
- Supplied with setting standards
- Carbide measuring faces

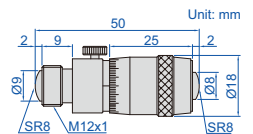

Code	Range	Extension rods (mm)
3222-63	50-63mm	—
3222-150	50-150mm	13, 25, 50
3222-300	50-300mm	13, 25, 50 (2 pcs), 100
3222-500	50-500mm	13, 25, 50 (2 pcs), 100, 200
3222-600	50-600mm	13, 25, 50, 100, 150, 200
3222-1000	50-1000mm	13, 25, 50 (2 pcs), 100, 200 (2 pcs), 300
3222-1500	50-1500mm	13, 25, 50 (2 pcs), 100, 200 (3 pcs), 300 (2 pcs)

THREE POINTS INTERNAL MICROMETERS

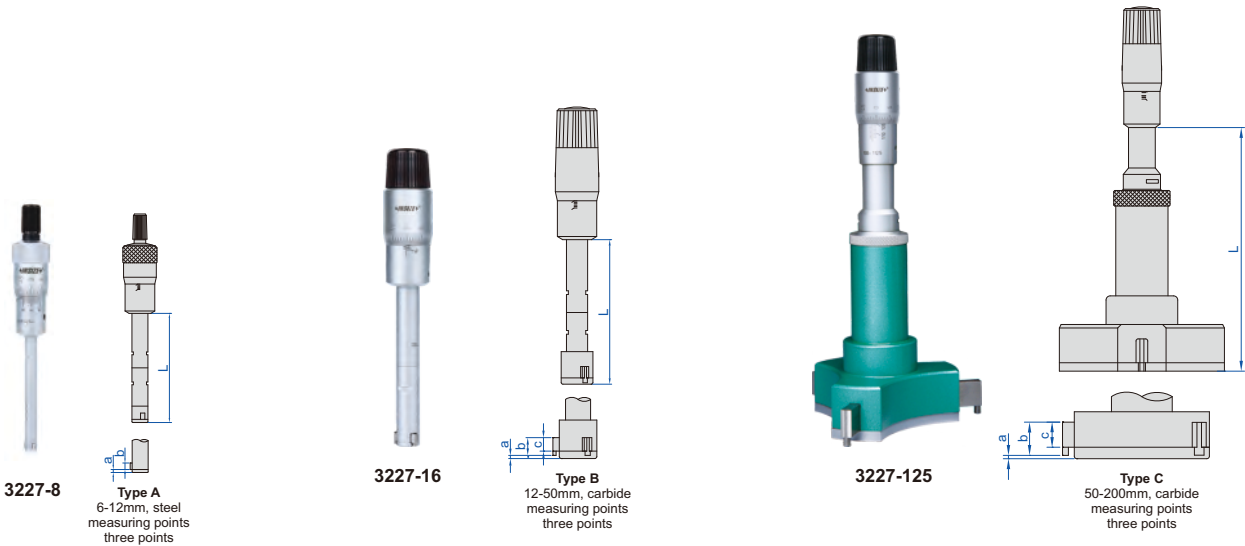

- Meet DIN863-4
- 6-12mm: graduation 0.001mm, 12-200mm: graduation 0.005mm
- Ratchet stop
- Optional accessory: setting rings (code 6312), micrometer stand and clamp (code 6301 and 6301-2)

extension rod (included)



setting ring



6-100mm: included
100-200mm: optional

micrometer stand with clamp (optional)



Individual

Code	Range	Type	Accuracy	Setting ring	Extension rod (included)	L	a	b	c
3227-8*	6-8mm	A	4µm	Ø6mm (included)	100mm	54.5	1.5	2.5	—
3227-10*	8-10mm	A	4µm	Ø8mm (included)	100mm	54.5	1.5	2.5	—
3227-12*	10-12mm	A	4µm	Ø10mm (included)	100mm	54.5	1.5	2.5	—
3227-16*	12-16mm	B	4µm	Ø16mm (included)	150mm	80	0.5	6	4.5
3227-20*	16-20mm	B	4µm	Ø16mm (included)	150mm	80	0.5	6	4.5
3227-25*	20-25mm	B	4µm	Ø25mm (included)	150mm	90	0.5	8	6
3227-30*	25-30mm	B	4µm	Ø25mm (included)	150mm	90	0.5	8	6
3227-40*	30-40mm	B	4µm	Ø40mm (included)	150mm	97	0.5	14	12
3227-50*	40-50mm	B	5µm	Ø40mm (included)	150mm	97	0.5	14	12
3227-63*	50-63mm	C	5µm	Ø62mm (included)	150mm	114	0.5	17.5	14.5
3227-75*	62-75mm	C	5µm	Ø62mm (included)	150mm	114	0.5	17.5	14.5
3227-88*	75-88mm	C	5µm	Ø87mm (included)	150mm	114	0.5	17.5	14.5
3227-100*	87-100mm	C	5µm	Ø87mm (included)	150mm	114	0.5	17.5	14.5
3227-125*	100-125mm	C	6µm	optional	150mm	140	0.9	29	25
3227-150*	125-150mm	C	6µm	optional	150mm	140	0.9	29	25
3227-175*	150-175mm	C	7µm	optional	150mm	140	0.9	29	25
3227-200*	175-200mm	C	7µm	optional	150mm	140	0.9	29	25

Set

Code	Range	Micrometers included	Setting ring (included)	Extension rod (included)
3227-123*	6-12mm	6-8mm, 8-10mm, 10-12mm	Ø6mm, Ø8mm, Ø10mm	100mm
3227-202*	12-20mm	12-16mm, 16-20mm	Ø16mm	150mm
3227-504*	20-50mm	20-25mm, 25-30mm, 30-40mm, 40-50mm	Ø25mm, Ø40mm	150mm
3227-1004*	50-100mm	50-63mm, 62-75mm, 75-88mm, 87-100mm	Ø62mm, Ø87mm	150mm



3227-504

*Supplied with manufacturer inspection certificate

DIGITAL TWO POINTS/THREE POINTS INTERNAL MICROMETERS

IP65
WATERPROOF

DATA
OUTPUT

INSPECTION
CERTIFICATE



3127-5

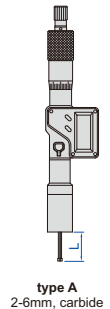

type A
2-6mm, carbide measuring points two points



3127-12

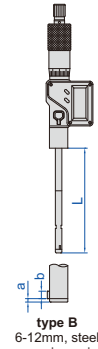

type B
6-12mm, steel measuring points three points



3127-40

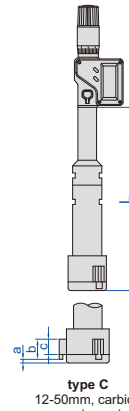

type C
12-50mm, carbide measuring points three points



3127-125

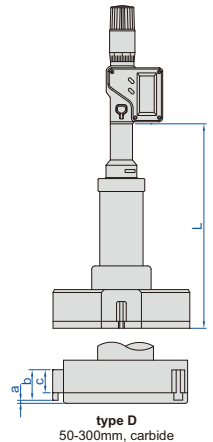

type D
50-300mm, carbide measuring points three points

- Resolution 0.001mm/0.00005" (resolution of **3127-275** and **3127-300** is 0.001mm/0.0001")
- IP65 dust/waterproof
- Buttons: on/off, set, mm/inch, data transmit
- Data output, automatic power off
- Ratchet stop
- Optional accessory: data output cable (code **7315-31** receiver is needed, **7302-30**), setting ring (code **6312**), micrometer stand and clamp (code **6301** and **6301-2**)

extension rod (included)



setting ring



2-100mm: included
100-300mm: optional

micrometer stand with clamp (optional)



Individual

Code	Range	Type	Accuracy	Setting ring	Extension rod (included)	L	a	b	c
3127-2 *	2-2.5mm/0.08-0.10"	A (two points)	6µm	Ø2.5 (included)	—	12	—	—	—
3127-3 *	2.5-3mm/0.10-0.12"	A (two points)	6µm	Ø2.5 (included)	—	12	—	—	—
3127-4 *	3-4mm/0.12-0.16"	A (two points)	6µm	Ø4 (included)	—	22	—	—	—
3127-5 *	4-5mm/0.16-0.20"	A (two points)	6µm	Ø5 (included)	—	22	—	—	—
3127-6 *	5-6mm/0.20-0.24"	A (two points)	6µm	Ø6 (included)	—	22	—	—	—
3127-8 *	6-8mm/0.24-0.31"	B (three points)	4µm	Ø6 (included)	100	57	1.5	2.5	—
3127-10 *	8-10mm/0.31-0.39"	B (three points)	4µm	Ø8 (included)	100	57	1.5	2.5	—
3127-12 *	10-12mm/0.39-0.47"	B (three points)	4µm	Ø10 (included)	100	57	1.5	2.5	—
3127-16 *	12-16mm/0.47-0.63"	C (three points)	4µm	Ø16 (included)	150	99	0.5	6	4.5
3127-20 *	16-20mm/0.63-0.79"	C (three points)	4µm	Ø16 (included)	150	99	0.5	6	4.5
3127-25 *	20-25mm/0.79-0.98"	C (three points)	4µm	Ø25 (included)	150	105	0.5	8	6
3127-30 *	25-30mm/0.98-1.18"	C (three points)	4µm	Ø25 (included)	150	105	0.5	8	6
3127-40 *	30-40mm/1.18-1.57"	C (three points)	4µm	Ø40 (included)	150	110	0.5	14	12
3127-50 *	40-50mm/1.57-1.97"	C (three points)	5µm	Ø40 (included)	150	110	0.5	14	12
3127-63 *	50-63mm/1.97-2.48"	D (three points)	5µm	Ø62 (included)	150	127	0.5	17.5	14.5
3127-75 *	62-75mm/2.44-2.95"	D (three points)	5µm	Ø62 (included)	150	127	0.5	17.5	14.5
3127-88 *	75-88mm/2.95-3.46"	D (three points)	5µm	Ø87 (included)	150	127	0.5	17.5	14.5
3127-100 *	87-100mm/3.43-3.94"	D (three points)	5µm	Ø87 (included)	150	127	0.5	17.5	14.5
3127-125 *	100-125mm/3.94-4.92"	D (three points)	6µm	optional	150	175	0.9	29	25
3127-150 *	125-150mm/4.92-5.91"	D (three points)	6µm	optional	150	175	0.9	29	25
3127-175 *	150-175mm/5.91-6.89"	D (three points)	7µm	optional	150	175	0.9	29	25
3127-200 *	175-200mm/6.89-7.87"	D (three points)	7µm	optional	150	175	0.9	29	25
3127-225	200-225mm/7.87-8.86"	D (three points)	8µm	optional	150	175	0.9	29	25
3127-250	225-250mm/8.86-9.84"	D (three points)	8µm	optional	150	175	0.9	29	25
3127-275	250-275mm/9.84-10.83"	D (three points)	9µm	optional	150	175	0.9	29	25
3127-300	275-300mm/10.83-11.81"	D (three points)	9µm	optional	150	175	0.9	29	25

Set

Code	Range	Micrometers included	Setting ring (included)	Extension rod (included)
3127-232 *	2-3mm/0.08-0.12"	2-2.5mm, 2.5-3mm	Ø2.5mm	—
3127-363 *	3-6mm/0.12-0.24"	3-4mm, 4-5mm, 5-6mm	Ø4mm, Ø5mm, Ø6mm	—
3127-123 *	6-12mm/0.24-0.47"	6-8mm, 8-10mm, 10-12mm	Ø6mm, Ø8mm, Ø10mm	100mm
3127-202 *	12-20mm/0.47-0.79"	12-16mm, 16-20mm	Ø16mm	150mm
3127-504 *	20-50mm/0.79-1.97"	20-25mm, 25-30mm, 30-40mm, 40-50mm	Ø25mm, Ø40mm	150mm
3127-1004 *	50-100mm/1.97-3.94"	50-63mm, 62-75mm, 75-88mm, 87-100mm	Ø62mm, Ø87mm	150mm



3127-202

* Supplied with manufacturer inspection certificate

DIGITAL WIDE RANGE THREE POINTS INTERNAL MICROMETERS

IP54
WATERPROOF

DATA
OUTPUT

INSPECTION
CERTIFICATE

- Meet DIN863-4
- Resolution 0.001mm/0.00005"
(resolution of **3128-300** is 0.001mm/0.0001")
- IP54 dust/waterproof
- Buttons: on/off, set, mm/inch
- Data output
- Automatic power off
- Carbide measuring faces
- Ratchet stop
- Supplied with extension rods
- Setting rings are included (except 200-300mm)
- Optional accessory: data output cable
(code **7315-30** receiver is needed, **7302-30**)

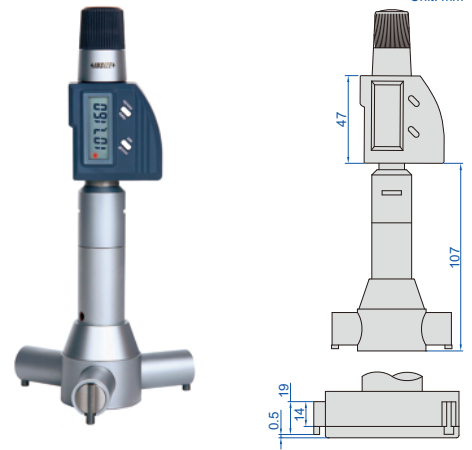

3128-150



Code	Range	Accuracy	Setting ring	Extension rod (included)
3128-70*	50-70mm/1.97-2.76"	5µm	Ø50mm (included)	150mm
3128-100*	70-100mm/2.76-3.94"	5µm	Ø70mm (included)	150mm
3128-150*	100-150mm/3.94-5.91"	6µm	Ø100mm (included)	150mm
3128-250*	150-250mm/5.91-9.84"	8µm	Ø150mm (included)	150mm
3128-300*	200-300mm/7.87-11.81"	9µm	Ø200mm (optional)	150mm

*Supplied with manufacturer inspection certificate

PRECISION BORE GAGES FOR SMALL HOLES (WITH DIAL INDICATOR)

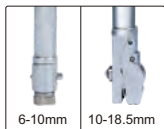

- Accuracy: ±0.007mm
- Optional accessory: setting ring (code **6312**), bore gage setter



2853-10

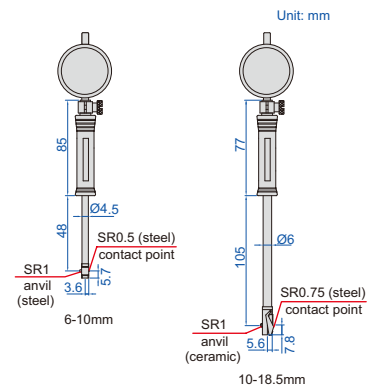

Code	Range	Indicator	Repeatability
2853-10	6-10mm	dial indicator, range 1mm,	0.0015mm
2853-18	10-18.5mm	graduation 0.001mm (code 2313-1FA)	0.0015mm

BORE GAGES FOR SMALL HOLES (WITH DIAL INDICATOR)

ATTENTION: NOT SUITABLE FOR 0.001MM DIAL INDICATORS

- Accuracy: ±0.012mm
- Repeatability: 0.003mm
- Optional accessory: setting ring (code **6312**), bore gage setter

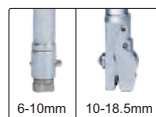

2852-10

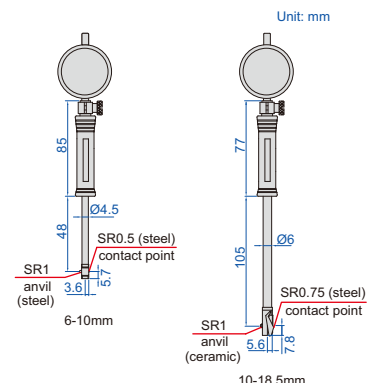

Code	Range	Indicator
2852-10	6-10mm	dial indicator, range 3mm,
2852-18	10-18.5mm	graduation 0.01mm (code 2311-3F)

PRECISION BORE GAGES (WITH DIAL INDICATOR)

- Repeatability: 0.0015mm
- Optional accessory: setting ring (code **6312**), long handle (code **7351**), bore gage setter

Range	A	B	C	ØD
35-60mm	22	9	27	13
50-160mm	26	9	35	13

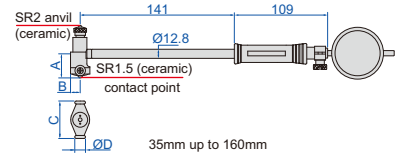
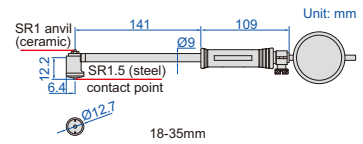

Code	Range	Indicator	Accuracy
2825-35	18-35mm	dial indicator, range 1mm, graduation 0.001mm (code 2313-1FA)	±0.007mm
2825-60	35-60mm		±0.007mm
2825-160	50-160mm		±0.007mm

2825-160

BORE GAGES (WITH DIAL INDICATOR)

POPULAR MODEL

ATTENTION: NOT SUITABLE FOR 0.001MM DIAL INDICATORS



- Repeatability: 0.003mm
- Optional accessory: setting ring (code **6312**), long handle (code **7351**), bore gage setter

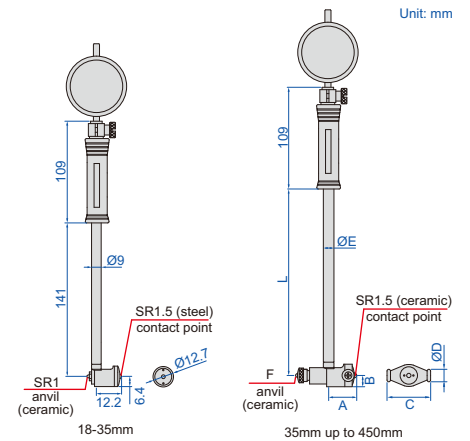

2322-160A

Code	Range	Indicator	Accuracy
2322-35A	18-35mm	dial indicator, range 10mm, graduation 0.01mm (code 2308-10FA)	±0.015mm
2322-60A	35-60mm		±0.018mm
2322-160A	50-160mm		±0.018mm
2322-250A	160-250mm		±0.018mm
2322-450A	250-450mm		±0.018mm

Range	A	B	C	ØD	ØE	F	L
35-60mm	22	9	27	13	12.8	SR2	141
50-160mm	26	9	35	13	12.8	SR2	141
160-250mm	56.5	13	74.5	15	12.8	SR2	241
250-450mm	86.5	15	101.5	15	14.5	SR2.5	241

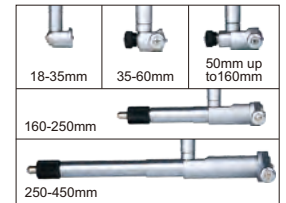

BORE GAGE (WITH DIAL INDICATOR)

ATTENTION: NOT SUITABLE FOR 0.001MM DIAL INDICATORS

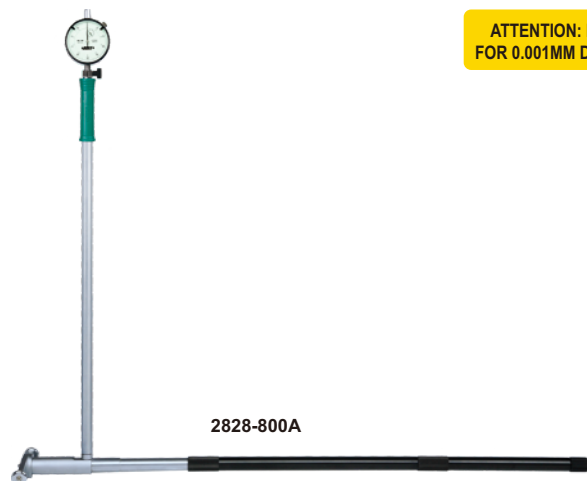
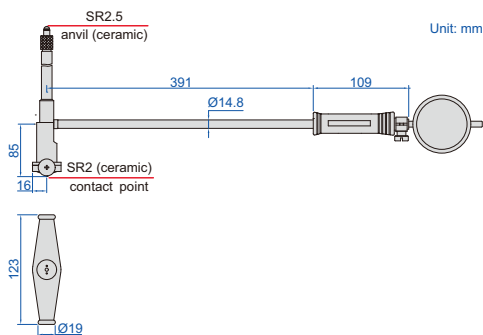

2828-800A

Code	Range	Accuracy	Repeatability	Indicator
2828-800A	400-800mm	±0.025mm	0.003mm	dial indicator, code 2308-10FA , range 10mm, graduation 0.01mm

BORE GAGE SETS (WITH DIAL INDICATOR)

ATTENTION: NOT SUITABLE FOR 0.001MM DIAL INDICATORS

packaging (code 2824-S3)

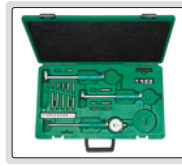

- Repeatability: 0.003mm
- Optional accessory: setting ring (code 6312), bore gage setter, long handle (code 7351)

Code	Range	Indicator	Bore gages included	Accuracy
2824-S160	35-160mm	dial indicator, code 2308-10FA, range 10mm, graduation 0.01mm	① 35-50mm (dial indicator and handle are not included) ② 50-160mm	35-50mm ±0.018mm 50-160mm ±0.018mm
2824-S3	18-160mm		① 18-35mm ② 35-60mm (dial indicator is not included) ③ 50-160mm (dial indicator is not included)	18-35mm ±0.015mm 35-60mm ±0.018mm 50-160mm ±0.018mm



BORE GAGES (WITH DIAL INDICATOR)

ATTENTION: NOT SUITABLE FOR 0.001MM DIAL INDICATORS

- Optional accessory: setting ring (code 6312), long handle (code 7351), bore gage setter

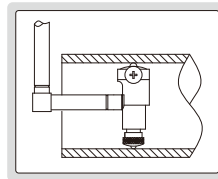

Range	ØA	B	C	ØD	E	L	L1
35-60mm	12.8	22	9	13	27	141	75
50-160mm	12.8	28.5	9.2	13	35	141	76.2

Code	Range	Indicator	Accuracy	Repeatability
2827-60A	35-60mm	dial indicator, code 2308-10FA, range 10mm, graduation 0.01mm	±0.018mm	0.003mm
2827-160A	50-160mm	dial indicator, code 2308-10FA, range 10mm, graduation 0.01mm	±0.018mm	0.003mm

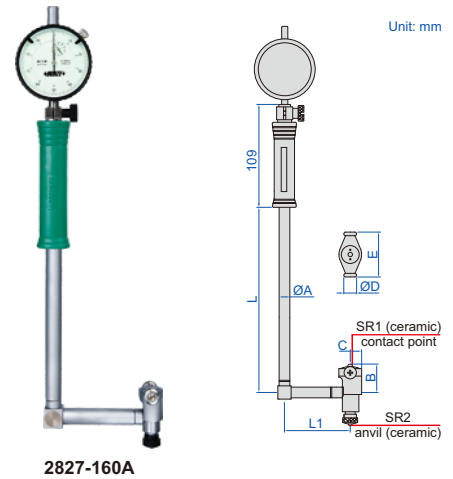

BORE GAGE SETTER

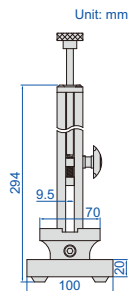
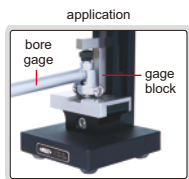

- Vertical and horizontal use
- To be used with gage blocks
- With gage block set

7353-160

gage blocks (included)



horizontal use



Gage block set

Blocks per set	Size (mm)	Step (mm)	Quantity	Remark
33	1.005	0.01	1 pc	grade 2 (ISO3650)
	1.01-1.09		9 pcs	
	1.1-1.9	0.1	9 pcs	
	1-9	1	9 pcs	
	10-30	10	3 pcs	
	50		1 pc	
	100		1 pc	

Code	Range	Repeatability
7353-160	0-160mm	1.2µm

LONG HANDLE TELESCOPING GAGES

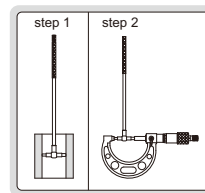

4209-6

- For quick measurement of inside diameter of deep holes and width of slots
- Satin chrome finish



Code	Range	L	Øa	Øb	Øc
4209-1	8-12.7mm	300mm	3.9mm	2.9mm	6.2mm
4209-2	12.7-19mm	300mm	5.3mm	3.8mm	6.2mm
4209-3	19-32mm	300mm	5.3mm	3.8mm	6.2mm
4209-4	32-54mm	300mm	7.6mm	6.1mm	7.2mm
4209-5	54-90mm	300mm	7.6mm	6.1mm	7.2mm
4209-6	90-150mm	300mm	7.6mm	6.1mm	7.2mm

SMALL HOLE GAGE SET



4208-1

- 4 gages per set
- For small holes, slots and grooves, etc.
- Satin chrome finish

Code	Total range	Gages included
4208-1	3-13mm	3-5mm, 5-7.5mm, 7.5-10mm, 10-13mm

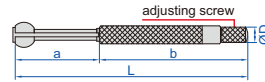

Range	L	a	b	ØD
3-5mm	76	24	52	5
5-7.5mm	79	27	52	5
7.5-10mm	88	30	58	6
10-13mm	91	34	58	6

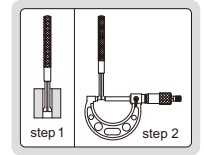

TELESCOPING GAGE SET

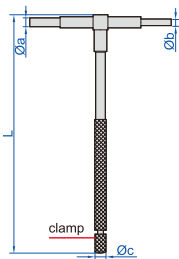

4206-1

- 6 gages per set
- For quick measurement of inside diameter of holes and width of slots
- Satin chrome finish

Range	L	Øa	Øb	Øc
8-12.7mm	115mm	3.9mm	2.9mm	6.2mm
12.7-19mm	115mm	5.3mm	3.8mm	6.2mm
19-32mm	115mm	5.3mm	3.8mm	6.2mm
32-54mm	137mm	7.6mm	6.1mm	7.2mm
54-90mm	137mm	7.6mm	6.1mm	7.2mm
90-150mm	137mm	7.6mm	6.1mm	7.2mm

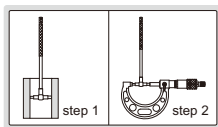

Code	Total range	Gages included
4206-1	8-150mm	8-12.7mm, 12.7-19mm, 19-32mm, 32-54mm, 54-90mm, 90-150mm

FLEXIBLE INNER DIAMETER METERS



7137-60



application



- Measure average inner diameter of flexible materials
- Made of PET

Code	Diameter range	Graduation	Accuracy
7137-30	Ø10-30mm	0.05mm	±0.10mm
7137-60	Ø30-60mm	0.05mm	±0.10mm
7137-100	Ø50-100mm	0.05mm	±0.10mm
7137-200	Ø100-200mm	0.05mm	±0.10mm
7137-350	Ø200-350mm	0.05mm	±0.15mm

CIRCUMFERENCE METERS (ECONOMIC TYPE)

- Measure diameter and circumference of soft materials like pipes, trees, tires, etc.
- Graduation: 0.1mm
- Laser engraved scale
- Made of stainless steel



7114-950

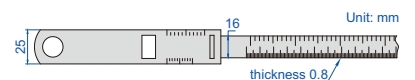

Code	Circumference range	Diameter range	Accuracy	
			circumference	diameter
7114-950	150-950mm	Ø50-300mm	±3mm	±1mm
7114-2200	940-2200mm	Ø300-700mm	±3mm	±1mm
7114-3460	2190-3460mm	Ø700-1100mm	±3mm	±1mm

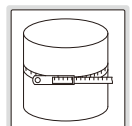

DIAMETER METERS

CAN BE CUSTOM-MADE

- Measure diameter of pipes, trees, tires, etc.
- Made of stainless steel



7135-525

Code	Diameter range	Graduation	Accuracy
7135-35*	Ø20-35mm	0.05mm	±0.05mm
7135-55*	Ø30-55mm	0.05mm	±0.05mm
7135-125	Ø50-125mm	0.01mm	±0.05mm
7135-225	Ø100-225mm	0.01mm	±0.05mm
7135-375	Ø200-375mm	0.01mm	±0.05mm
7135-525	Ø350-525mm	0.01mm	±0.05mm
7135-725	Ø500-725mm	0.01mm	±0.06mm
7135-925	Ø700-925mm	0.01mm	±0.06mm
7135-1125	Ø900-1125mm	0.02mm	±0.06mm
7135-1325	Ø1100-1325mm	0.02mm	±0.08mm
7135-1525	Ø1300-1525mm	0.02mm	±0.08mm
7135-1725	Ø1500-1725mm	0.02mm	±0.08mm
7135-1925	Ø1700-1925mm	0.02mm	±0.08mm
7135-2125	Ø1900-2125mm	0.02mm	±0.08mm
7135-2325	Ø2100-2325mm	0.02mm	±0.10mm
7135-2525	Ø2300-2525mm	0.02mm	±0.10mm
7135-2750	Ø2500-2750mm	0.02mm	±0.10mm
7135-3000	Ø2750-3000mm	0.02mm	±0.10mm
7135-3250	Ø3000-3250mm	0.02mm	±0.15mm
7135-3500	Ø3250-3500mm	0.02mm	±0.15mm

Code	Diameter range	Graduation	Accuracy
7135-3750	Ø3500-3750mm	0.02mm	±0.15mm
7135-4000	Ø3750-4000mm	0.02mm	±0.20mm
7135-4250	Ø4000-4250mm	0.02mm	±0.20mm
7135-4500	Ø4250-4500mm	0.02mm	±0.20mm
7135-4750	Ø4500-4750mm	0.02mm	±0.20mm
7135-5000	Ø4750-5000mm	0.02mm	±0.20mm
7135-5250	Ø5000-5250mm	0.02mm	±0.005%L**
7135-5500	Ø5250-5500mm	0.02mm	±0.005%L**
7135-5750	Ø5500-5750mm	0.02mm	±0.005%L**
7135-6000	Ø5750-6000mm	0.02mm	±0.005%L**
7135-6250	Ø6000-6250mm	0.02mm	±0.005%L**
7135-6500	Ø6250-6500mm	0.02mm	±0.005%L**
7135-6750	Ø6500-6750mm	0.02mm	±0.005%L**
7135-7000	Ø6750-7000mm	0.02mm	±0.005%L**
7135-7250	Ø7000-7250mm	0.02mm	±0.005%L**
7135-7500	Ø7250-7500mm	0.02mm	±0.005%L**
7135-7750	Ø7500-7750mm	0.02mm	±0.005%L**
7135-8000	Ø7750-8000mm	0.02mm	±0.005%L**
7135-8250	Ø8000-8250mm	0.02mm	±0.005%L**

** L is the actual measured value (unit: mm)

* The thickness of code 7135-35 and 7135-55 is 0.10mm, while the thickness of other codes is 0.25mm

CIRCUMFERENCE METERS

CAN BE CUSTOM-MADE

- Measure diameter and circumference of pipes, trees, tires, etc.
- Made of stainless steel

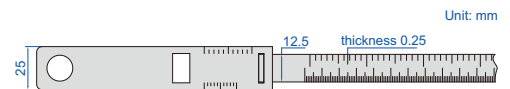
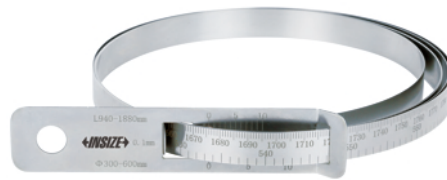

7136-1880

Code	Circumference range	Diameter range	Graduation	Accuracy	
				circumference	diameter
7136-940	160-940mm	Ø50-300mm	0.1mm	±0.30mm	±0.10mm
7136-1880	940-1880mm	Ø300-600mm	0.1mm	±0.30mm	±0.10mm
7136-2830	1880-2830mm	Ø600-900mm	0.1mm	±0.30mm	±0.10mm
7136-3770	2830-3770mm	Ø900-1200mm	0.1mm	±0.30mm	±0.10mm
7136-4710	3770-4710mm	Ø1200-1500mm	0.1mm	±0.30mm	±0.10mm
7136-5650	4710-5650mm	Ø1500-1800mm	0.1mm	±0.30mm	±0.10mm
7136-6600	5650-6600mm	Ø1800-2100mm	0.1mm	±0.30mm	±0.10mm
7136-7540	6600-7540mm	Ø2100-2400mm	0.1mm	±0.30mm	±0.10mm
7136-8480	7540-8480mm	Ø2400-2700mm	0.1mm	±0.30mm	±0.10mm
7136-9430	8480-9430mm	Ø2700-3000mm	0.1mm	±0.30mm	±0.10mm

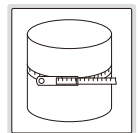



Outside Diameter Measuring
Instruments
Page 63



Outside Diameter Variation Measuring
Instruments
Page 64



Digital Radius Gages
Page 65-66



Digital Radius Gages
Page 65



Digital Arc Radius Calipers
Page 66



Digital Radius Calipers
Page 66

OUTSIDE DIAMETER MEASURING INSTRUMENTS



digital/dial indicators
is optional

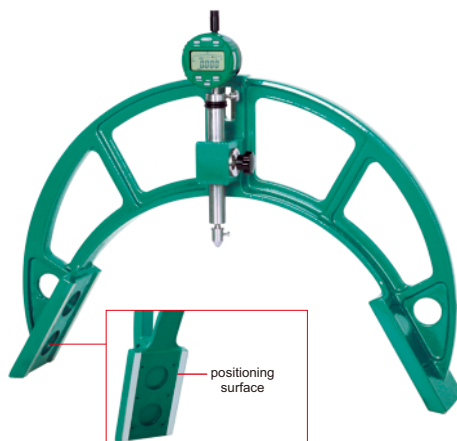

2716-500

- Need standard workpieces to set zero
- The frame is made of aluminum magnesium alloy with light weight and high strength
- Optional accessory: 0.01mm or 0.001mm digital/dial indicators

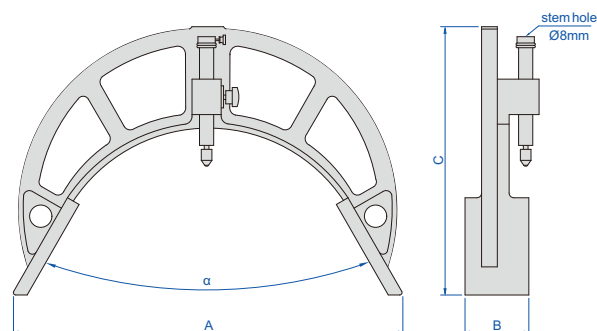

Code	Range (diameter)	Repeatability	α	A	B	C	Weight
2716-60	18-60mm	0.01mm	60°	140mm	60mm	160mm	1kg
2716-120	60-120mm	0.01mm	60°	160mm	65mm	192mm	1.5kg
2716-200	120-200mm	0.01mm	60°	225mm	70mm	228mm	2kg
2716-300	200-300mm	0.01mm	60°	330mm	80mm	262mm	2.5kg
2716-400	300-400mm	0.01mm	60°	405mm	80mm	303mm	4kg
2716-500	400-500mm	0.01mm	60°	494mm	80mm	340mm	5kg
2716-600	500-600mm	0.01mm	60°	594mm	80mm	398mm	6kg
2716-700	600-700mm	0.01mm	60°	685mm	80mm	446mm	7.5kg
2716-800	700-800mm	0.01mm	60°	772mm	80mm	479mm	9kg
2716-900	800-900mm	0.01mm	60°	860mm	80mm	520mm	10kg
2716-1000	900-1000mm	0.01mm	60°	950mm	80mm	560mm	11.5kg
2716-1100	1000-1100mm	0.01mm	60°	1035mm	90mm	575mm	13kg
2716-1200	1000-1200mm	0.01mm	83.62°	960mm	100mm	460mm	12kg
2716-1300	1100-1300mm	0.01mm	83.62°	1000mm	100mm	485mm	13.5kg
2716-1400	1200-1400mm	0.01mm	83.62°	1100mm	100mm	512mm	15kg
2716-1600	1400-1600mm	0.01mm	83.62°	1260mm	100mm	540mm	17kg
2716-1800	1600-1800mm	0.01mm	83.62°	1460mm	100mm	570mm	19kg
2716-2000	1800-2000mm	0.01mm	83.62°	1645mm	100mm	605mm	21kg

OUTSIDE DIAMETER VARIATION MEASURING INSTRUMENTS

CAN BE CUSTOM-MADE

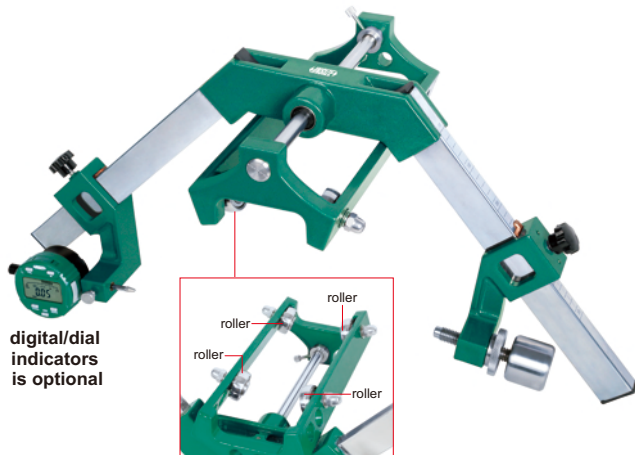

digital/dial indicators is optional

2715-350



VIDEO

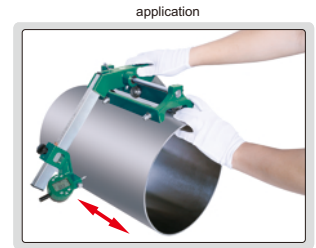

application

Unit: mm

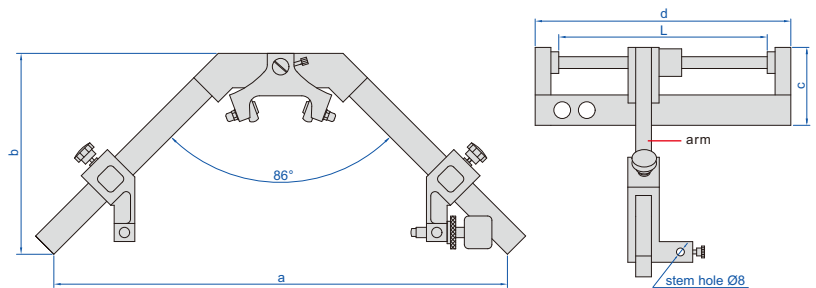

- Measurement of diameter variation, convexity, concavity, taper and other parameters
- Continuous measurement in the axis direction
- Four rollers are included
- Optional accessory: 0.01mm or 0.001mm graduation digital/dial indicators

Code	Range (diameter)	Accuracy	Repeatability	Arm moving range (L)	a	b	c	d	Weight
2715-350	100-350mm/4-14"	0.01mm	3µm	200mm	500mm	230mm	80mm	260mm	4kg
2715-500	200-500mm/8-20"	0.01mm	3µm	151mm	630mm	260mm	95mm	260mm	5kg
2715-700	300-700mm/12-28"	0.01mm	3µm	197mm	910mm	372mm	112mm	320mm	6.5kg
2715-1000	500-1000mm/20-40"	0.01mm	3µm	190mm	1170mm	460mm	120mm	320mm	8kg
2715-1600	800-1600mm/32-64"	0.02mm	6µm	202mm	1860mm	690mm	180mm	320mm	12.5kg
2715-2000	1400-2000mm/56-80"	0.02mm	6µm	232mm	2156mm	860mm	210mm	350mm	18.5kg

LARGE RANGE DIGITAL RADIUS GAGE

DATA OUTPUT

Unit: mm



2197

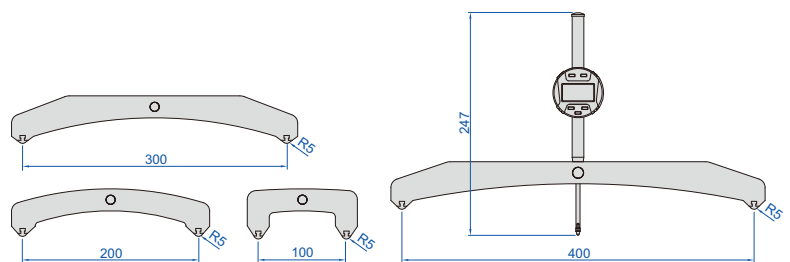

- Measure radius of internal or external arcs
- Resolution: 0.01mm/0.001"
- Buttons: on/off, hold, mm/inch, s (select jaws), zero
- Display can be rotated by 320°
- Supplied with 4 jaws for different sizes of arc
- Battery CR2032, data output
- Automatic power off (time is adjustable)
- Optional accessory: data output cable (code 7315-2183 receiver is needed, 7302-2183)



VIDEO

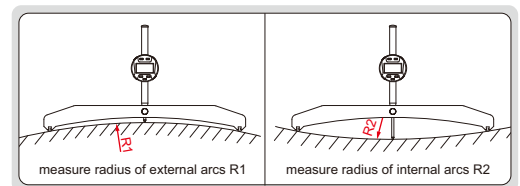

Code	Range of external radius (R1)	Range of internal radius (R2)	Accuracy (mm)
2197	100-15000mm/4-590"	100-15000mm/4-590"	±0.005R*

*R is the radius to be measured. For example, radius is 100mm, the accuracy is ±0.005x100=±0.5mm

DIGITAL RADIUS GAGES

DATA
OUTPUT



- Measure radius of external arc, arc angle of measured surface should be larger than 60°
- Display radius value, no need to calculate
- Button function: on/off, zero, data preset, inch/mm
- Keep preset data in memory after restart
- CR2032 battery, automatic power off (time is adjustable)
- Data output
- Stainless steel base
- Optional accessory: setting standards, data output cable (code 7315-50M receiver is needed, 7302-40M)



2188-55



2188-233



2188-143



2188-323

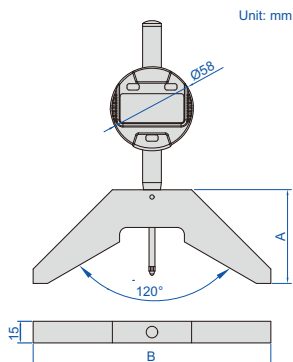

Code	Range (radius)	Resolution	Accuracy	A	B
2188-55	4-53mm/0.16-2.09"	0.01mm/0.0005"	±0.02mm	40mm	65mm
2188-143	48-143mm/1.89-5.63"	0.01mm/0.0005"	±0.03mm	65mm	165mm
2188-233	138-233mm/5.43-9.17"	0.01mm/0.0005"	±0.03mm	85mm	255mm
2188-323	228-323mm/8.98-12.72"	0.01mm/0.0005"	±0.04mm	95mm	345mm

Setting standards

Code	Setting standards	Remark
4110-10D00	setting standard for 2188-55	included
2188-P143	setting standard for 2188-143	optional
2188-P233	setting standard for 2188-233	optional
2188-P323	setting standard for 2188-323	optional

application

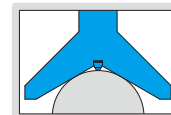

setting standard application



2188-P143

DIGITAL RADIUS GAGE (LOW ACCURACY)

DATA
OUTPUT

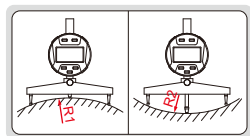

- Resolution: 0.01mm/0.001"
- Buttons: on/off, hold, mm/inch, s (select jaws), zero
- Measure radius of internal or external arcs
- Display can be rotated by 320°
- Supplied with 5 jaws for different sizes of arc
- Data output, battery CR2032
- Automatic power off (time is adjustable)
- Optional accessory: calibration standard (code 2183-BLOCK), data output cable (code 7315-2183 receiver is needed, 7302-2183)



2183

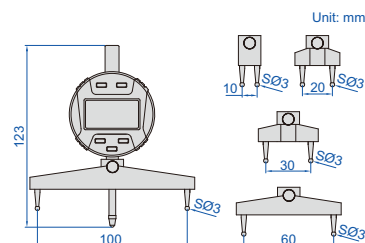

2183-BLOCK

calibration standard
application



Code	Range of external radius (R1)	Range of internal radius (R2)	Accuracy (mm)
2183	5-910mm/0.2-35.83"	7-910mm/0.3-35.83"	±0.01R*

*R is the radius to be measured. For example, radius is 100mm, the accuracy is ±0.01x100=±1mm

Calibration standard (optional)

Code	Remark
2183-BLOCK	includes 5 standard blocks

DIGITAL RADIUS GAGE



DATA OUTPUT

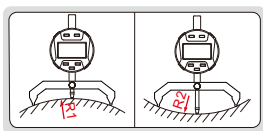

- Resolution: 0.01mm/0.001"
- Buttons: on/off, hold, mm/inch, s (select jaws), zero
- Measure radius of internal or external arcs
- Cylindrical measuring jaws, self-positioning
- Display can be rotated by 320°
- Supplied with 5 jaws for different sizes of arc
- Data output, battery CR2032
- Automatic power off (time is adjustable)
- Optional accessory: calibration standard (code 2183-BLOCK), data output cable (code 7315-2183 receiver is needed, 7302-2183)



2511

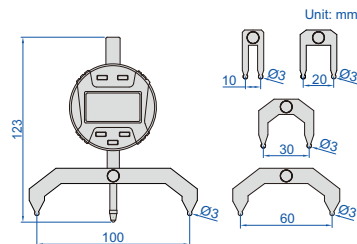

2183-BLOCK



Code	Range of external radius (R1)	Range of internal radius (R2)	Accuracy (mm)
2511	5-910mm/0.2-35.83"	7-910mm/0.3-35.83"	±0.005R*

*R is the radius to be measured. For example, radius is 100mm, the accuracy is ±0.005x100=±0.5mm

Calibration standard (optional)

Code	Remark
2183-BLOCK	includes 5 standard blocks

DIGITAL ARC RADIUS CALIPERS

DATA OUTPUT

- Non waterproof
- Measure the radius of arc less than half round
- Resolution: 0.01mm/0.0005"
- Buttons: on/off, zero, mm/inch
- Automatic power off, move the digital unit to turn on power
- Battery CR2032
- Made of stainless steel

With data interface (data output cable code 7315-21 receiver is needed, 7302-21, optional)

Code	Range (R)	Accuracy	L	c	d
1189-150B	5-150mm/0.2-6"	±0.05mm	263mm	16mm	65mm
1189-200B	5-200mm/0.2-8"	±0.07mm	313mm	16mm	85mm

Built-in wireless (receiver code 7315-2/3/6/7/8/9 is needed)

Code	Range (R)	Accuracy	L	c	d
1189-150BWL	5-150mm/0.2-6"	±0.05mm	263mm	16mm	65mm
1189-200BWL	5-200mm/0.2-8"	±0.07mm	313mm	16mm	85mm



1189-200B

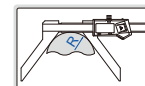
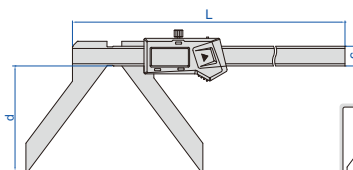

DIGITAL RADIUS CALIPERS

DIRECT READING, CALCULATION IS NOT REQUIRED

DATA OUTPUT

- Non waterproof
- Measure radius of external arc, arc angle of measured surface should be larger than 90°
- Resolution: 0.01mm/0.0005"
- Buttons: on/off, zero, mm/inch
- Automatic power off, move the digital unit to turn on power
- Battery CR2032, data output
- Made of stainless steel
- Supplied with pin gage for zero setting
- Optional accessory: data output cable (code 7315-21 receiver is needed, 7302-21)



1501-25

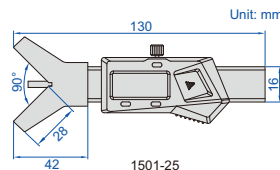

1501-25

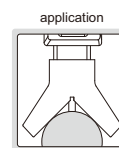

1501-10

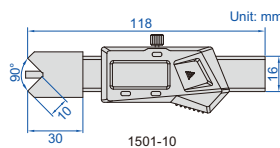

1501-10

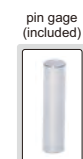

1501-10 can measure small workpieces or workpieces with steps

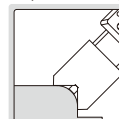

Code	Range (radius)	Accuracy
1501-25	2-25mm/0.079-1"	±0.05mm
1501-10	2-10mm/0.079-0.394"	±0.05mm



Keyway Symmetry Gages
Page 68



Keyway Symmetry Digital Calipers
Page 68



Dial Keyway Depth Gages
Page 68

KEYWAY SYMMETRY GAGE

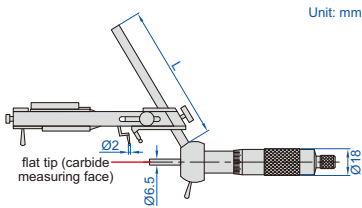

Unit: mm



4865-14



- Used to measure the symmetry of shaft keyways

Code	Range		Graduation	Accuracy	L
	diameter of shaft	width of keyway			
4865-14	14-110mm	5-28mm	0.01mm	0.02mm	100mm

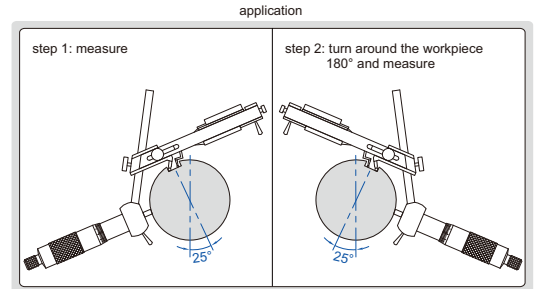

KEYWAY SYMMETRY DIGITAL CALIPERS

DATA OUTPUT

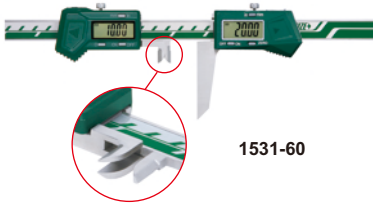

1531-60

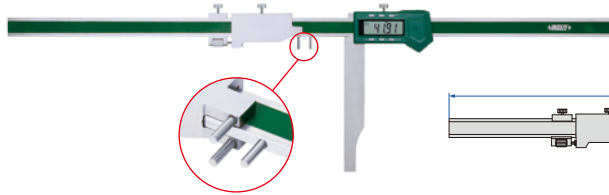

1531-200

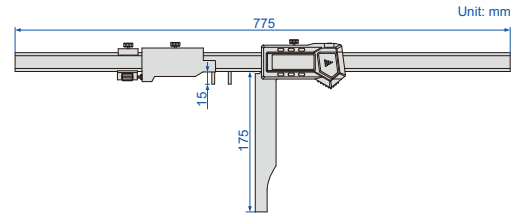

Unit: mm

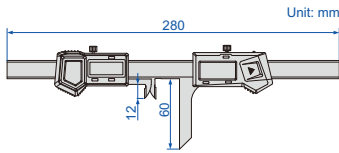

Unit: mm

- Non waterproof
- Used to measure the symmetry of shaft keyways
- Resolution: 0.01mm/0.0005"
- Buttons: on/off, zero, mm/inch
- Automatic power off, move the digital unit to turn on power
- Battery CR2032, data output
- Made of stainless steel
- Optional accessory: data output cable (code 7315-22 receiver is needed, 7302-22)

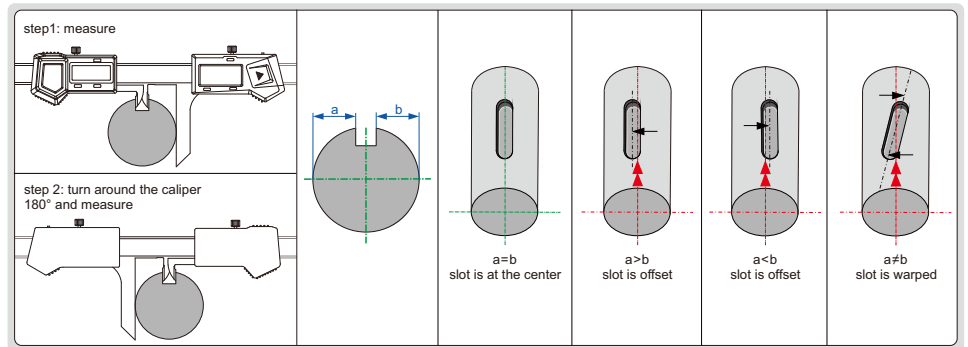

Code	Width of keyway	Diameter of shaft	Accuracy	Remarks
1531-60	6-45mm	Ø10-120mm	±0.05mm	can measure keyway width
1531-200	3-250mm	Ø6-350mm	±0.05mm	cannot measure keyway width

DIAL KEYWAY DEPTH GAGE

- Graduation: 0.01mm
- Measure keyway depth of cylindrical workpieces with diameter Ø10-100mm
- Stainless steel base
- Pointed tip

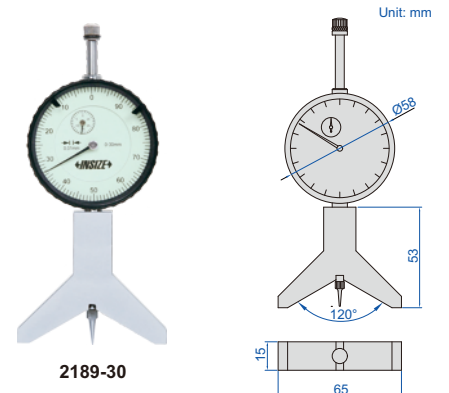
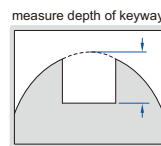
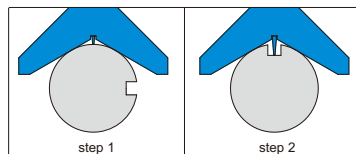

2189-30

Unit: mm

Code	Range	Accuracy
2189-30	0-30mm	±0.03mm



Chamfer Gages
Page 70



Digital Chamfer Gages
Page 70



Digital Chamfer Gages
Page 70

CHAMFER GAGE

- Accuracy: $\pm 0.25\text{mm}$
- To measure internal and external chamfers
- Made of stainless steel

Code	Graduation
4844-1	0.5mm

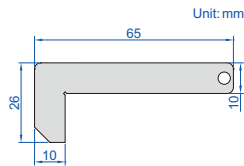

4844-1

for internal chamfer measurement, diameter should be larger than $\text{Ø}11\text{mm}$

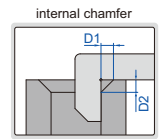
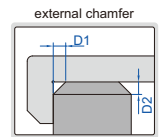
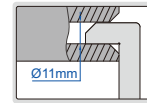

CHAMFER GAGES

- Measure $30^\circ/45^\circ/60^\circ$ chamfer dimension
- Accuracy: $\pm 0.06\text{mm}$
- Graduation: 0.02mm
- Made of stainless steel
- Satin chrome plated reading surface

Code	Range	Chamfer (α)	ØD
1267-6	0-10mm	45°	7mm
1267-63	0-10mm	30°	8mm
1267-66	0-10mm	60°	7mm

for internal chamfer measurement, diameter should be larger than ØD

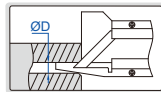

1267-6

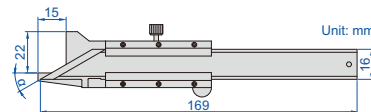

measure chamfer dimension

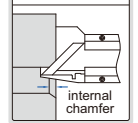
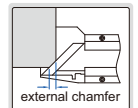

DIGITAL CHAMFER GAGES

- Non waterproof
- Measure $30^\circ/45^\circ/60^\circ$ chamfer dimension
- Resolution: $0.01\text{mm}/0.0005"$
- Buttons: on/off, zero, mm/inch
- Automatic power off, move the digital unit to turn on power
- Battery CR2032, data output
- Made of stainless steel
- Optional accessory: data output cable (code 7315-21 receiver is needed, 7302-21)



1180-6

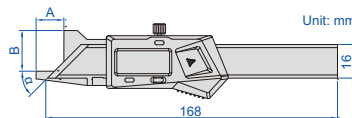

for internal chamfer measurement, diameter should be larger than ØD

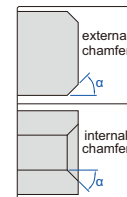
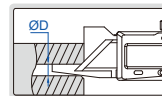

measure chamfer dimension

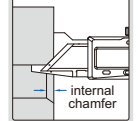
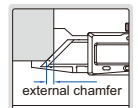

DATA OUTPUT

Code	Range	Accuracy	Chamfer (α)	A	B	ØD
1180-6	0-10mm/0-0.39"	$\pm 0.06\text{mm}$	45°	15mm	22mm	7mm
1180-63	0-10mm/0-0.39"	$\pm 0.06\text{mm}$	30°	15mm	22mm	8mm
1180-66	0-10mm/0-0.39"	$\pm 0.06\text{mm}$	60°	14mm	21mm	7mm

DIGITAL CHAMFER GAGES

ATTENTION: CHAMFER OF HOLES CANNOT BE MEASURED

DIRECT READING, CALCULATION IS NOT REQUIRED

DATA OUTPUT

- Non waterproof
- Measure 45° chamfer length
- Resolution: $0.01\text{mm}/0.0005"$
- Buttons: on/off, zero, mm/inch
- Automatic power off, move the digital unit to turn on power
- Battery CR2032, data output
- Made of stainless steel
- Supplied with pin gage for zero setting
- Optional accessory: data output cable (code 7315-21 receiver is needed, 7302-21)



1537-20

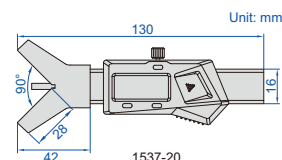

1537-8

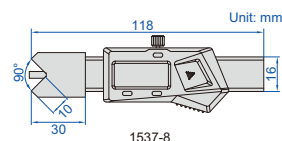

VIDEO

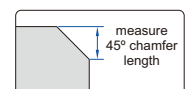

1537-8 can measure small workpieces or workpieces with steps

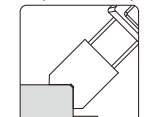

pin gage (included)



Code	Range	Accuracy
1537-20	0-20mm/0-0.787"	$\pm 0.05\text{mm}$
1537-8	0-8mm/0-0.315"	$\pm 0.05\text{mm}$

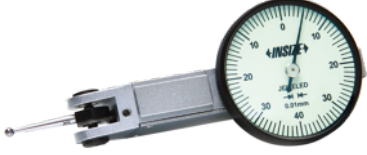

Dial Test Indicators
Page 72-73



Digital Indicators
Page 73-77



Zeroing Foot Switches
Page 77



High Precision Digital Indicators
Page 78



Dial Indicators
Page 78-80



Points
Page 80-81



Backs
Page 82



Linear Gages And Display Units
Page 82-83



Dial Test Indicator Holders
Page 84



Magnetic Stands
Page 85-87



Dial Indicator Stands (Non-Magnetic)
Page 87-88



Dial Indicator Stands
Page 88-89

DIAL TEST INDICATORS

INSPECTION CERTIFICATE

JEWELLED BEARING

POPULAR MODEL

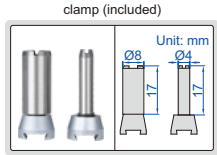

2380-08



2381-02

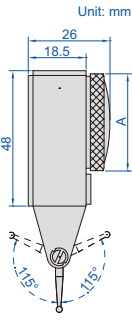

- Meet DIN2270 (except 2380-02, 2381-02, 2381-021)
- Jeweled bearing
- Carbide contact point
- Two measuring directions
- Anti magnetic body
- Supplied with two clamps: diameter Ø4mm and Ø8mm
- Optional accessory: styli

Graduation: 0.01mm

Code	Range	Accuracy	Hysteresis	Dial reading	A	L
2380-08*	0.8mm	13µm	3µm	0-40-0	Ø30mm	13.5mm
2381-08*	0.8mm	13µm	3µm	0-40-0	Ø37mm	13.5mm

Graduation: 0.002mm

Code	Range	Accuracy	Hysteresis	Dial reading	A	L
2380-02*	0.2mm	6µm	2µm	0-100-0	Ø30mm	12.5mm
2381-02*	0.2mm	6µm	2µm	0-100-0	Ø37mm	12.5mm

Graduation: 0.001mm

Code	Range	Accuracy	Hysteresis	Dial reading	A	L
2381-021*	0.2mm	6µm	2µm	0-100-0	Ø37mm	12.5mm

*Supplied with manufacturer inspection certificate

LONG STYLUS DIAL TEST INDICATOR

INSPECTION CERTIFICATE

JEWELLED BEARING



2383-08A

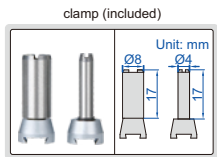

2383-08A

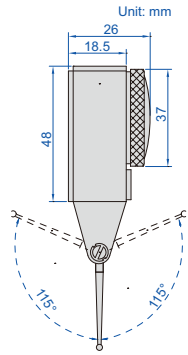

- Meet DIN2270
- Jeweled bearing
- Carbide contact point
- Two measuring directions
- Anti magnetic body
- Supplied with two clamps: diameter Ø4mm and Ø8mm
- Optional accessory: styli

Code	Range	Graduation	Accuracy	Hysteresis	Dial reading
2383-08A*	0.8mm	0.01mm	13µm	3µm	0-40-0

*Supplied with manufacturer inspection certificate

LARGE RANGE DIAL TEST INDICATOR

INSPECTION CERTIFICATE

JEWELLED BEARING



2386-16A

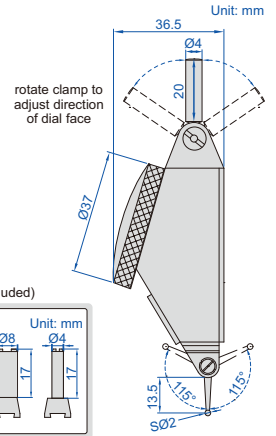
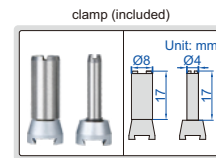

- Jeweled bearing
- Carbide contact point
- Two measuring directions
- Anti magnetic body
- Supplied with two clamps: diameter Ø4mm and Ø8mm
- Optional accessory: styli

Code	Range	Graduation	Accuracy	Hysteresis	Dial reading
2386-16A*	1.6mm	0.01mm	25µm	8µm	0-40-0

*Supplied with manufacturer inspection certificate

TILTED FACE TYPE DIAL TEST INDICATOR

INSPECTION CERTIFICATE

JEWELLED BEARING



2399-08

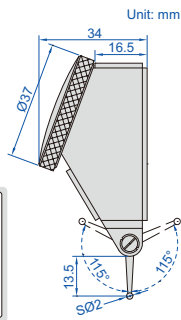
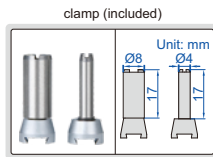

- Meet DIN2270
- Jeweled bearing
- Carbide contact point
- Two measuring directions
- Anti magnetic body
- Supplied with two clamps: diameter Ø4mm and Ø8mm
- Optional accessory: styli

Code	Range	Graduation	Accuracy	Hysteresis	Dial reading
2399-08*	0.8mm	0.01mm	13µm	3µm	0-40-0

*Supplied with manufacturer inspection certificate

VERTICAL TYPE DIAL TEST INDICATOR

INSPECTION CERTIFICATE

JEWELLED BEARING



2398-08

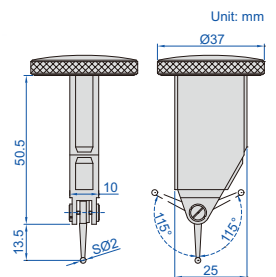
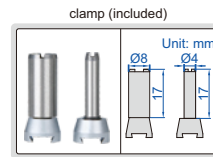

- Meet DIN2270
- Jeweled bearing
- Carbide contact point
- Two measuring directions
- Anti magnetic body
- Supplied with two clamps: diameter Ø4mm and Ø8mm
- Optional accessory: styli

Code	Range	Graduation	Accuracy	Hysteresis	Dial reading
2398-08*	0.8mm	0.01mm	13µm	3µm	0-40-0

*Supplied with manufacturer inspection certificate

LARGE RANGE VERTICAL TYPE DIAL TEST INDICATOR

INSPECTION CERTIFICATE

JEWELLED BEARING

- Dial Reading: 0-40-0
- Jeweled bearing
- Carbide contact point
- Two measuring directions
- Anti magnetic body
- Supplied with two clamps: diameter Ø4mm and Ø8mm
- Optional accessory: styli

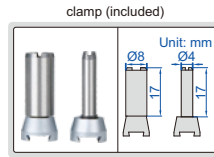

2480-16

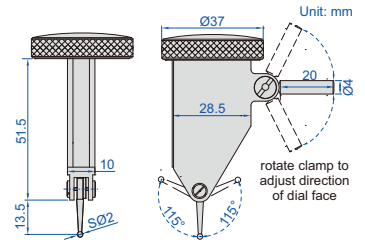

Code	Range	Graduation	Accuracy	Hysteresis
2480-16 *	1.6mm	0.01mm	18µm	3µm

* Supplied with manufacturer inspection certificate

DIGITAL INDICATORS (STANDARD TYPE)

DATA OUTPUT

INSPECTION CERTIFICATE

POPULAR MODEL



2112-10

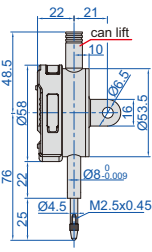

2112-10
2112-101



2112-251

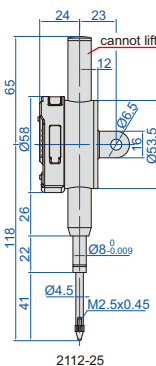

2112-25
2112-251



2112-25P

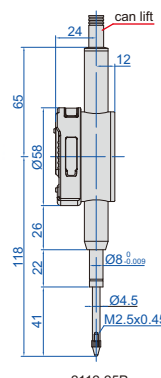

2112-25P
2112-251P



2112-501

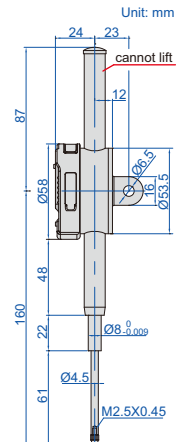

2112-50
2112-501

- Button function: on/off, inch/mm, zero, data preset, change measuring direction, absolute/incremental measurement
- Switchable high/low frequency measurement mode, high frequency mode is suitable for high speed moving of spindle and has large power consumption, low power consumption in low frequency mode
- Keep preset data in memory after restart
- CR2032 battery, data output
- Automatic power off (time is adjustable),
- Optional accessory: data output cable (code 7315-50M receiver is needed, 7302-40M, 7305-40M), backs, contact points

Resolution 0.001mm/0.00005"

Code	Range	Accuracy	Hysteresis	Maximum measuring force	Remark
2112-101F *	12.7mm/0.5"	5µm	2µm	1.5N	flat back
2112-251F *	25.4mm/1"	5µm	3µm	2.2N	flat back
2112-501F *	50.8mm/2"	6µm	3µm	2.5N	flat back
2112-101 *	12.7mm/0.5"	5µm	2µm	1.5N	lug back
2112-251 *	25.4mm/1"	5µm	3µm	2.2N	lug back
2112-501 *	50.8mm/2"	6µm	3µm	2.5N	lug back
2112-251P *	25.4mm/1"	5µm	3µm	2.2N	flat back, with lift cap
2112-501P *	50.8mm/2"	6µm	3µm	2.5N	flat back, with lift cap

Resolution 0.01mm/0.0005"

Code	Range	Accuracy	Hysteresis	Maximum measuring force	Remark
2112-10F *	12.7mm/0.5"	20µm	10µm	1.5N	flat back
2112-25F *	25.4mm/1"	20µm	10µm	2.2N	flat back
2112-50F *	50.8mm/2"	30µm	10µm	2.5N	flat back
2112-10 *	12.7mm/0.5"	20µm	10µm	1.5N	lug back
2112-25 *	25.4mm/1"	20µm	10µm	2.2N	lug back
2112-50 *	50.8mm/2"	30µm	10µm	2.5N	lug back
2112-25P *	25.4mm/1"	20µm	10µm	2.2N	flat back, with lift cap
2112-50P *	50.8mm/2"	30µm	10µm	2.5N	flat back, with lift cap

* Supplied with manufacturer inspection certificate

2112-251P/501P/25P/50P



spindle lift knob is included



DIGITAL INDICATORS (ADVANCED TYPE)

DATA OUTPUT

INSPECTION CERTIFICATE

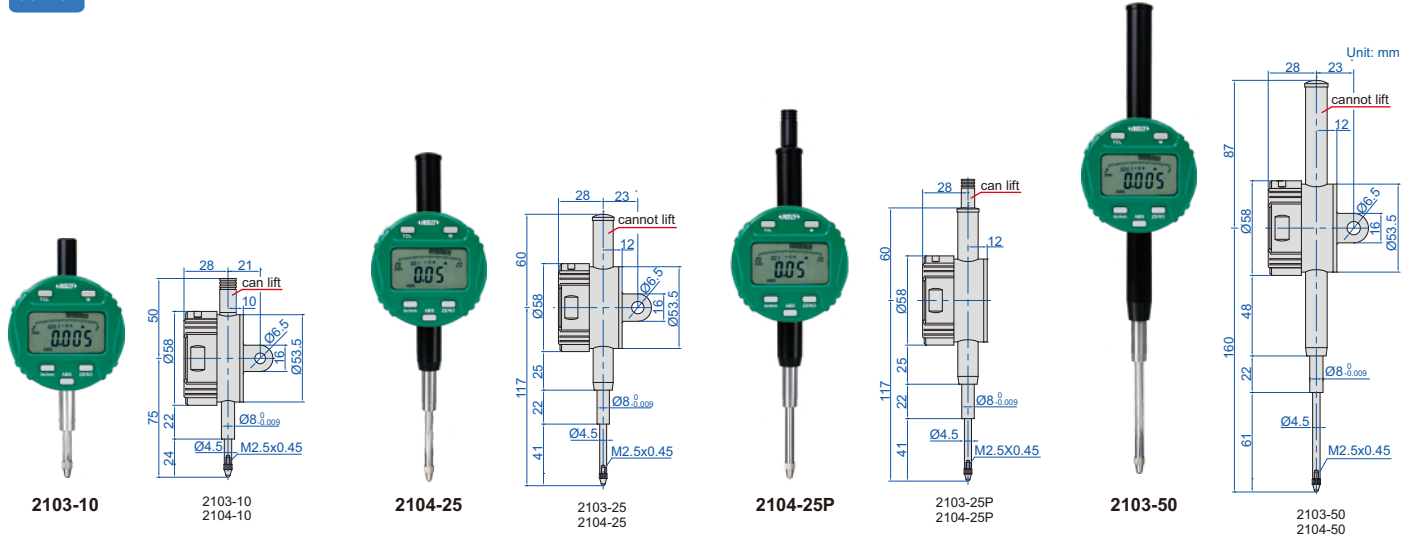

- Reading in digital and analog
- Display can be rotated by 320°
- Button function: tolerance Go and No-Go display, data preset, measuring direction change, max./min./TIR measurement, inch/metric conversion, absolute/incremental measurement
- Keep preset data and tolerance data in memory after restart
- CR2032 battery, automatic power off (time is adjustable)
- Data output
- Optional accessory: data output cable (code 7315-50M receiver is needed, 7302-40M, 7305-40M), backs, contact points

spindle lift knob is included



max./min./TIR

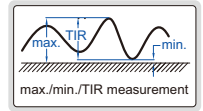

analog pointer

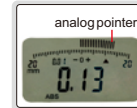

warning when over tolerance

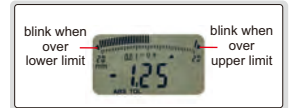

Resolution 0.001mm/0.00005"

Code	Range	Accuracy	Hysteresis	Maximum measuring force	Remark
2103-10F*	12.7mm/0.5"	5µm	2µm	1.5N	flat back
2103-25F*	25.4mm/1"	5µm	3µm	2.2N	flat back
2103-50F*	50.8mm/2"	6µm	3µm	2.5N	flat back
2103-10*	12.7mm/0.5"	5µm	2µm	1.5N	lug back
2103-25*	25.4mm/1"	5µm	3µm	2.2N	lug back
2103-50*	50.8mm/2"	6µm	3µm	2.5N	lug back
2103-25P*	25.4mm/1"	5µm	3µm	2.2N	flat back, with lift cap
2103-50P*	50.8mm/2"	6µm	3µm	2.5N	flat back, with lift cap

Resolution 0.01mm/0.0005"

Code	Range	Accuracy	Hysteresis	Maximum measuring force	Remark
2104-10F*	12.7mm/0.5"	20µm	10µm	1.5N	flat back
2104-25F*	25.4mm/1"	20µm	10µm	2.2N	flat back
2104-50F*	50.8mm/2"	30µm	10µm	2.5N	flat back
2104-10*	12.7mm/0.5"	20µm	10µm	1.5N	lug back
2104-25*	25.4mm/1"	20µm	10µm	2.2N	lug back
2104-50*	50.8mm/2"	30µm	10µm	2.5N	lug back
2104-25P*	25.4mm/1"	20µm	10µm	2.2N	flat back, with lift cap
2104-50P*	50.8mm/2"	30µm	10µm	2.5N	flat back, with lift cap

2103-25P/50P
2104-25P/50P



*Supplied with manufacturer inspection certificate

DIGITAL INDICATORS (WITH TRANSMISSION BUTTON AND SIGNAL LIGHT)



DATA OUTPUT

- Reading in digital and analog
- Display can be rotated by 320°
- Button function: on/off, zero, tolerance Go and No-Go display, data preset, measuring direction change, max./min./TIR measurement, inch/metric conversion, absolute/incremental measurement, data output
- Keep preset data and tolerance data in memory after restart
- CR2032 battery, automatic power off (time is adjustable)
- Data output
- Optional accessory: data output cable (code 7315-50M receiver is needed, 7302-40M, 7305-40M), backs, contact points

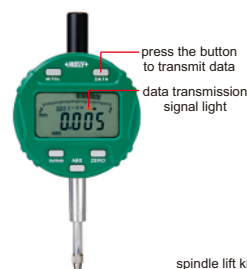
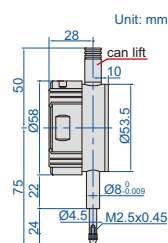

Resolution 0.001mm/0.00005"

Code	Range	Accuracy	Hysteresis	Maximum measuring force	Remark
2138-10F*	12.7mm/0.5"	5µm	2µm	1.5N	flat back

Resolution 0.01mm/0.0005"

Code	Range	Accuracy	Hysteresis	Maximum measuring force	Remark
2139-10F*	12.7mm/0.5"	20µm	10µm	1.5N	flat back

*Supplied with manufacturer inspection certificate

spindle lift knob is included



2138-10F

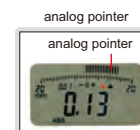
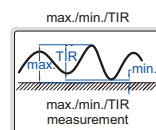

WATERPROOF DIGITAL INDICATORS



WATERPROOF

- Dust/waterproof
- Button function: on/off, zero, mm/inch, data preset, tolerance, change measuring direction, max./min./TIR measurement, absolute/incremental measurement
- Keep preset data and tolerance data in memory after restart
- CR2032 battery, automatic power off
- Data output
- Optional accessory: data output cable (code 7315-50M receiver is needed, 7302-40M, 7305-40M), backs, contact points

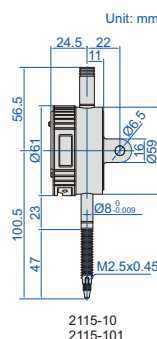

2115-10
2115-101



2115-25

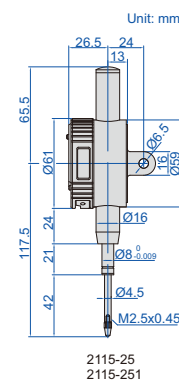

2115-25
2115-251

DATA OUTPUT

Resolution 0.001mm/0.00005"

Code	Range	Dust/waterproof	Accuracy	Hysteresis	Remark
2115-101*	12.7mm/0.5"	IP65	5µm	2µm	lug back
2115-251*	25.4mm/1"	IP54	5µm	3µm	lug back

Resolution 0.01mm/0.0005"

Code	Range	Dust/waterproof	Accuracy	Hysteresis	Remark
2115-10*	12.7mm/0.5"	IP65	20µm	10µm	lug back
2115-25*	25.4mm/1"	IP54	20µm	10µm	lug back

*Supplied with manufacturer inspection certificate

spindle lift knob is included (except 2115-101, 2115-10)

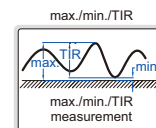

COMPACT DIGITAL INDICATORS



DATA OUTPUT

- Button function:
 - in/mm: short press for inch/metric conversion, long press to change measuring direction
 - ABS: short press for absolute/incremental measurement, long press to preset data
 - 0/ON: short press to turn on when power is off, short press to set zero when power is on, long press to turn off
- Keep preset data in memory after restart
- CR1632 battery, automatic power off
- Data output
- Optional accessory: data output cable (code 7315-50M receiver is needed, 7302-40M, 7305-40M), contact points



2114-5F

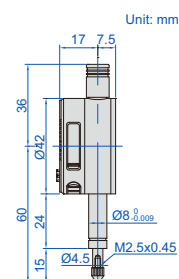

Code	Range	Resolution	Accuracy	Hysteresis	Remark
2114-5F*	5mm/0.2"	0.01mm/0.0005"	20µm	10µm	flat back
2114-51F*	5mm/0.2"	0.001mm/0.00005"	5µm	2µm	flat back

*Supplied with manufacturer inspection certificate

DIGITAL INDICATORS FOR BORE GAGES (WITH TRANSMISSION BUTTON AND SIGNAL LIGHT)

- Specially designed for bore gages
- The minimum value tracking function can find the diameter automatically
- Read the diameter directly, after inputting the size of setting ring
- Reading in digital and analog
- Display can be rotated by 320°
- Button function: on/off, minimum value tracking, calibration, data preset, inch/metric conversion
- Data remains after power off, no need to recalibrate after power on
- CR2032 battery
- Automatic power off (time is adjustable)
- Data output
- Optional accessory: data output cable (code **7315-50M** receiver is needed, **7302-40M**, **7305-40M**), backs, contact points, spindle lift knob

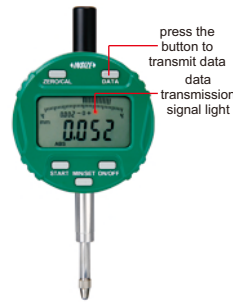
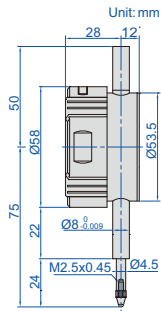

2108-10F

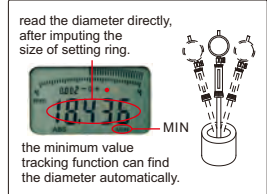
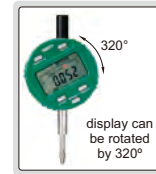

Code	Range	Resolution	Accuracy	Hysteresis	Remark
2108-10F*	12.7mm/0.5"	0.002mm/0.0001" (can switch to: 0.01mm/0.0005")	20µm	10µm	flat back
2108-101F*	12.7mm/0.5"	0.001mm/0.00005"	5µm	2µm	flat back

*Supplied with manufacturer inspection certificate

LARGE STROKE DIGITAL INDICATORS

DATA OUTPUT

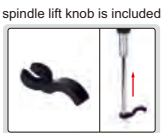
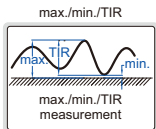

- Button function: on/off, zero, mm/inch, data preset, tolerance, change measuring direction, max./min./TIR measurement, absolute/incremental measurement
- Keep preset data and tolerance data in memory after restart
- CR2032 battery, automatic power off
- Maximum measuring force: 3.2N
- Data output
- Optional accessory: data output cable (code **7315-50M** receiver is needed, **7302-40M**, **7305-40M**), backs, contact points



2117-100

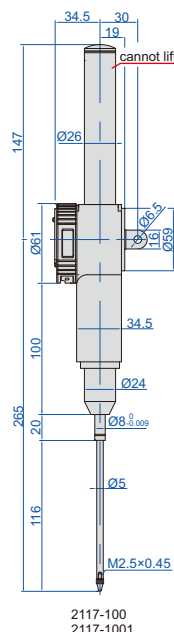

2117-100
2117-1001



2117-100P

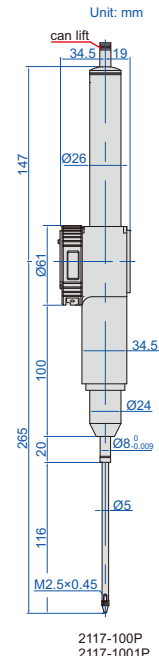

2117-100P
2117-1001P

Resolution 0.01mm/0.0005"

Code	Range	Accuracy	Hysteresis	Remark
2117-100	100mm/4"	30µm	10µm	lug back
2117-100P	100mm/4"	30µm	10µm	flat back, with lift cap

Resolution 0.001mm/0.00005"

Code	Range	Accuracy	Hysteresis	Remark
2117-1001	100mm/4"	9µm	3µm	lug back
2117-1001P	100mm/4"	9µm	3µm	flat back, with lift cap

2117-100P/1001P



ZEROING FOOT SWITCH

- For zeroing of digital indicators



7360-1M

Code	Description	Interface of digital indicators	Applicable products
7360-1M	zeroing foot switch with cable (length 2.5m)		for digital indicators

application

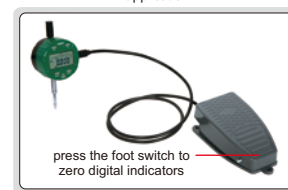

INDUCTIVE DIGITAL COMPARATOR (HIGH ACCURACY)

IP54 WATERPROOF

DATA OUTPUT

ATTENTION: RECHARGEABLE BATTERY, FOR 12 HOURS CONTINUOUS WORKING

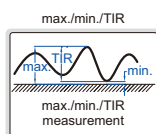

printer (optional)



- Built-in wireless transmission
- IP54 dust/waterproof
- Reading in digital and analog
- Display can be rotated by 320°
- Can store 10 set parameters, and the parameter can be searched and recalled
- 999 groups value can be stored
- Touch sensor: use the sensor to transmit data, avoiding press the button to cause deformation of the dial indicator stand and affect the zero position
- Button function: on/off, zero, data hold, measuring direction change, inch/metric conversion, data preset, absolute/incremental measurement, max./min./TIR measurement, tolerance Go and No-Go display, data output, analog pointer resolution and range change, print data
- Power: rechargeable battery, for 12 hours continuous working
- Ruby probe
- Data output
- Optional accessory: receiver (code 2149-RE, transmission distance is 2 meters), printer (code ISF-DF-PRINTER)



2149-2

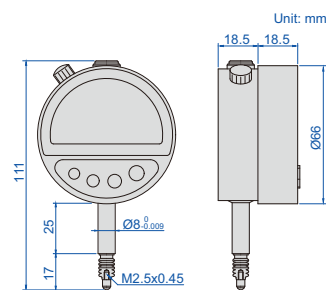

receiver (optional)



data interface (with protective cover)



Code	Range	Resolution	Accuracy	Hysteresis	Repeatability	Measuring force
2149-2	2mm/0.08"	0.1µm/0.000005"	0.5µm	0.2µm	0.3µm	0.8-1N

HIGH PRECISION DIGITAL INDICATORS



ABSOLUTE ENCODER, THE ORIGINAL DATA REMAINS AFTER POWER OFF

ATTENTION: RECHARGEABLE BATTERY, FOR 24 HOURS CONTINUOUS WORKING

DATA OUTPUT

LINEAR BALL BEARINGS FOR TEN MILLION TIMES USE

- Range: 12.7mm/0.5"
- Flat back
- Linear ball bearings for ten million times use
- Absolutely encoder, the original data remains after power off
- Reading in digital and analog
- Data output, with flat back
- Button function: data output, tolerance, data preset, data hold, measuring direction change, max./min./TIR, power off time, on/off, mm/inch, adjust resolution
- Power: rechargeable battery, for 24 hours continuous working
- Optional accessory: contact points, wireless transmitter, code 7315-60 receiver is needed data output cable (keyboard format), code 7302-60, data output cable (serial port format), code 7305-G60, (cable length 3m, optional cable length maximum 15m; RS232 protocol, optional RS485 protocol)

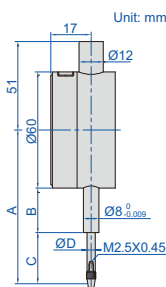

2133-10

spindle lift knob is included



max./min./TIR

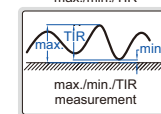

warning when over tolerance

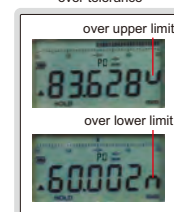

Standard precision

Carbide probe
Adjustable resolution: 0.0005mm/0.00002"
0.001mm/0.00005"
0.01mm/0.0005"

Code	Accuracy	Hysteresis
2133-10*	3µm	1.5µm

High precision

Ruby probe
Adjustable resolution: 0.0002mm/0.00001"
0.001mm/0.00005"
0.01mm/0.0005"

Code	Accuracy	Hysteresis
2133-101*	1.5µm	1µm

*Supplied with manufacturer inspection certificate

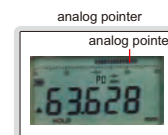

HIGH PRECISION DIGITAL INDICATOR

LINEAR BALL BEARINGS
FOR TEN MILLION TIMES USE

ATTENTION: RECHARGEABLE BATTERY,
FOR 24 HOURS CONTINUOUS WORKING

DATA
OUTPUT

Ø28MM STEM SUITABLE FOR
REINFORCED CLAMPING

ABSOLUTE ENCODER, THE ORIGINAL
DATA REMAINS AFTER POWER OFF

- Linear ball bearings for ten million times use
- Ø28mm stem suitable for reinforced clamping
- Absolute encoder, the original data remains after power off
- Adjustable resolution: 0.0002mm/0.0001"
0.001mm/0.0005"
0.01mm/0.0005"
- Reading in digital and analog
- Button function: data output, tolerance, data preset, data hold, measuring direction change, max./min./TIR, power off time, on/off, mm/inch, adjust resolution
- Power: rechargeable battery, for 24 hours continuous working
- Ruby probe

With data interface

Optional accessory:

wireless transmitter, code **7315-60** receiver is needed,
data output cable (keyboard format), code **7302-60**
data output cable (serial port format), code **7305-G60**
(cable length 3m, optional cable length maximum 15m;
RS232 protocol, optional RS485 protocol)

Code	Range	Accuracy	Hysteresis	Remark
2140-6	0-6mm/0-0.24"	1.6µm	0.8µm	flat back



2140-6

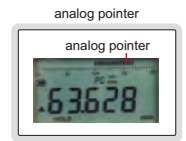
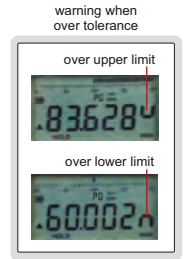
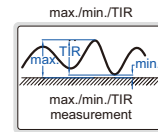
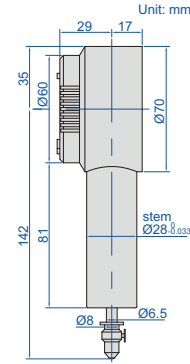

PRECISION DIAL INDICATORS

INSPECTION
CERTIFICATE

JEWELLED
BEARING



2313-1A

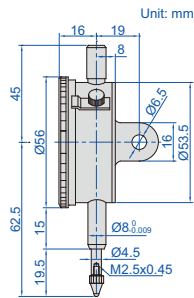

- Graduation: 0.001mm
- Dial reading: 0-100-0
- With lug back
- Jeweled bearing
- Supplied with limit pointers and bezel clamp
- Optional accessory: backs, contact points

Code	Range	Accuracy	Hysteresis	Range/rev
2313-1A*	1mm	5µm	2µm	0.2mm
2313-2A*	2mm	6µm	2.5µm	0.2mm

*Supplied with manufacturer inspection certificate

DIAL INDICATOR (BASIC TYPE)

INSPECTION
CERTIFICATE

POPULAR
MODEL

JEWELLED
BEARING



2301-10

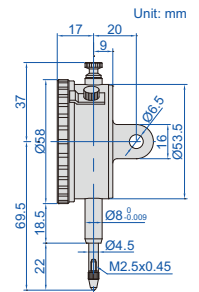

- Graduation: 0.01mm
- Accuracy: 17µm
- Dial reading: 0-100
- Meet DIN878
- Jeweled bearing
- Lug back with spare flat back
- Supplied with limit hands and bezel clamp
- Packed in carton box
- Optional accessory: backs, contact points

Code	Range	Hysteresis	Range/rev
2301-10*	10mm	3µm	1mm

*Supplied with manufacturer inspection certificate



COMPACT DIAL INDICATORS

INSPECTION
CERTIFICATE

JEWELLED
BEARING



2311-5

- Range/rev: 0.5mm
- Dial reading: 0-50
- Meet DIN878
- Jeweled bearing
- Supplied with limit pointers and bezel clamp
- Optional accessory: backs, contact points

Code	Range	Graduation	Accuracy	Hysteresis	Remark	B	D
2311-3*	3mm	0.01mm	12µm	3µm	lug back	46mm	10.5mm
2311-5*	5mm	0.01mm	14µm	3µm	lug back	48mm	12.5mm

*Supplied with manufacturer inspection certificate

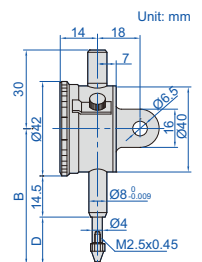

REVERSE READING DIAL INDICATOR

JEWELLED BEARING

INSPECTION CERTIFICATE



2801-10

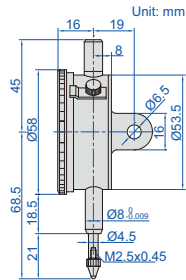

- Meet DIN878
- Dial reading: 100-0
- Suitable for depth and step measurements
- Jeweled bearing
- Lug back
- Supplied with limit pointers and bezel clamp
- Optional accessory: backs, contact points

Code	Range	Graduation	Accuracy	Hysteresis	Range/rev
2801-10*	10mm	0.01mm	17µm	3µm	1mm

*Supplied with manufacturer inspection certificate

SHOCKPROOF DIAL INDICATOR

SHOCK PROOF

JEWELLED BEARING

INSPECTION CERTIFICATE



2314-10A

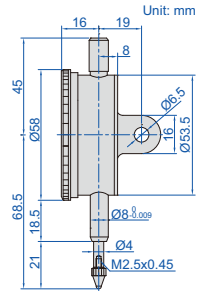

- Meet DIN878
- Dial reading: 100-0
- Shockproof
- Jeweled bearing
- Lug back
- Supplied with limit pointers and bezel clamp
- Optional accessory: backs, contact points

Code	Range	Graduation	Accuracy	Hysteresis	Range/rev
2314-10A*	10mm	0.01mm	17µm	3µm	1mm

*Supplied with manufacturer inspection certificate

WATERPROOF DIAL INDICATOR

IP54 WATERPROOF

INSPECTION CERTIFICATE



2324-10A

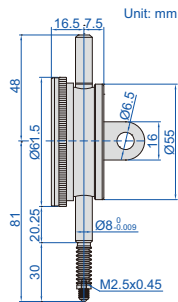

- Meet DIN878
- IP54 dust/waterproof
- Dial reading: 100-0
- Lug back
- With limit pointers
- Optional accessory: backs, contact points

Code	Range	Graduation	Accuracy	Hysteresis	Range/rev
2324-10A*	10mm	0.01mm	17µm	3µm	1mm

*Supplied with manufacturer inspection certificate

DIAL INDICATOR (LONG STROKE)

INSPECTION CERTIFICATE



2310-30A

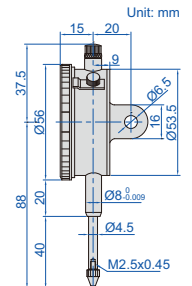

- Dial reading: 0-100
- Lug back
- Supplied with limit pointers and bezel clamp
- Optional accessory: backs, contact points

Code	Range	Graduation	Accuracy	Hysteresis	Range/rev
2310-30A*	30mm	0.01mm	35µm	7µm	1mm

*Supplied with manufacturer inspection certificate

DIAL INDICATOR (LONG STROKE, BASIC TYPE)

POPULAR MODEL

INSPECTION CERTIFICATE

- Lug back with spare flat back
- Supplied with limit pointers and bezel clamp
- Packed in carton box
- Optional accessory: backs, contact points



2302-25

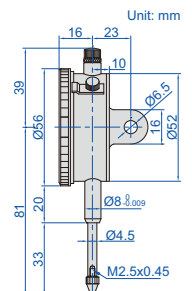

Code	Range	Graduation	Accuracy	Hysteresis	Range/rev	Dial reading
2302-25*	25mm	0.01mm	35µm	7µm	1mm	0-100

*Supplied with manufacturer inspection certificate

DIAL INDICATORS (LONG STROKE)



2309-50

- Shockproof
- Jeweled bearing
- Supplied with limit pointers
- Optional accessory: backs, contact points

stem clamp Ø10mm
for 2309-100D



back of type B

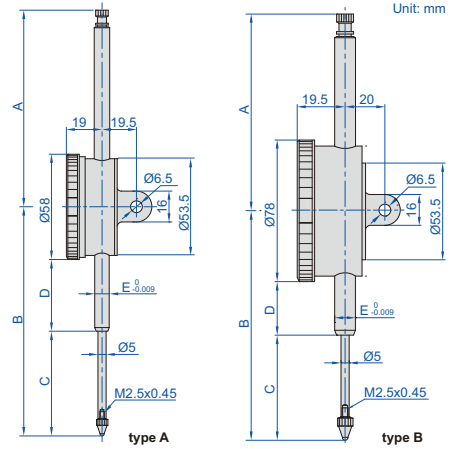

(mm)						
Code	Type	A	B	C	D	E
2309-50	A	108.3	126.2	57.7	39.5	Ø8
2309-100D	B	167.6	207.8	108	60.8	Ø10

Code	Range	Graduation	Type	Accuracy	Hysteresis	Range/rev	Dial reading	Remark
2309-50*	50mm	0.01mm	A	40µm	8µm	1mm	0-100	flat back with spare lug back
2309-100D	100mm	0.01mm	B	50µm	9µm	1mm	0-100	flat back with spare lug back

Note: 1) 2309-100D can only be used vertically
 2) 2309-100D is supplied with stem clamp Ø10mm for magnetic stands (code 6200-60, 6201-60, 6202-80, 6202-100)
 *Supplied with manufacturer inspection certificate

ONE REVOLUTION DIAL INDICATORS



2316-05

- Meet DIN878
- Eliminate the possibility of reading errors due to miscounting
- Shockproof
- Supplied with limit pointers
- Optional accessory: backs, contact points

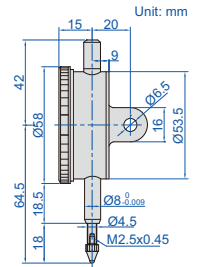

Code	Range	Dial indicator stroke	Graduation	Accuracy	Hysteresis	Dial reading	Remark
2316-05F*	0.5mm	5mm	0.01mm	9µm	3µm	25-0-25	flat back
2316-1F*	1mm	5mm	0.01mm	9µm	3µm	50-0-50	flat back
2316-05*	0.5mm	5mm	0.01mm	9µm	3µm	25-0-25	lug back
2316-1*	1mm	5mm	0.01mm	9µm	3µm	50-0-50	lug back

*Supplied with manufacturer inspection certificate

EXTENSION RODS



6282-2011

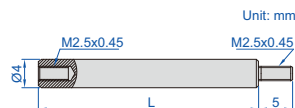

Code	Material	L
6282-2001	steel	10mm
6282-2002	steel	15mm
6282-2003	steel	20mm
6282-2004	steel	25mm
6282-2005	steel	30mm
6282-2006	steel	35mm
6282-2007	steel	40mm
6282-2008	steel	45mm
6282-2009	steel	50mm

Code	Material	L
6282-2010	steel	55mm
6282-2011	steel	60mm
6282-2012	steel	65mm
6282-2013	steel	70mm
6282-2014	steel	75mm
6282-2015	steel	80mm
6282-2016	steel	90mm
6282-2017	steel	100mm

CONTACT POINTS

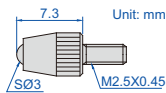

6282-0101

BALL POINT

Code	Material of measuring face
6282-0101	carbide

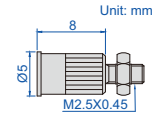

6282-1101

FLAT POINT

Code	Material of measuring face
6282-1101	steel

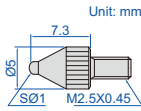

6282-0301

BALL POINT

Code	Material of measuring face
6282-0301	steel

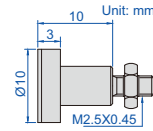

6282-1201

FLAT POINT

Code	Material of measuring face
6282-1201	steel

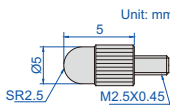

6282-0202

SHELL TYPE POINT

Code	Material of measuring face
6282-0202	steel

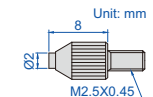

6282-1301

FLAT POINT

Code	Material of measuring face
6282-1301	carbide

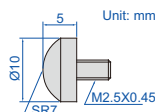

6282-0401

SPHERICAL POINT

Code	Material of measuring face
6282-0401	steel

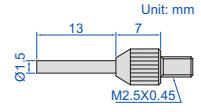

6282-1711

NEEDLE POINT

Code	Material of measuring face
6282-1711	carbide

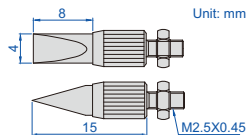
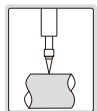

6282-1001

KNIFE EDGE POINT

Code	Material of measuring face
6282-1001	steel

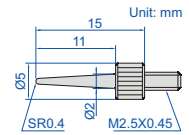

6282-1601

NEEDLE POINT

Code	Material of measuring face
6282-1601	steel

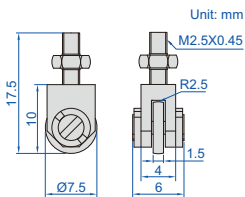

6282-1901

ROLLER POINT

Code	Material of measuring face
6282-1901	steel

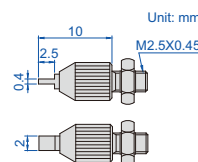

6282-1801

BLADE POINT

Code	Material of measuring face
6282-1801	steel

CONICAL POINTS

Code	Material of measuring face
6282-0601	steel
6282-0701	steel
6282-0801	steel
6282-0901	steel



6282-0601



6282-0701



6282-0801



6282-0901

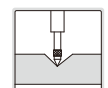
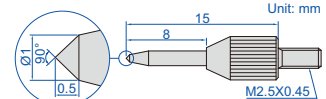
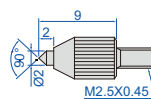
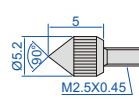
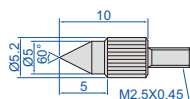

MAGNETIC BACK

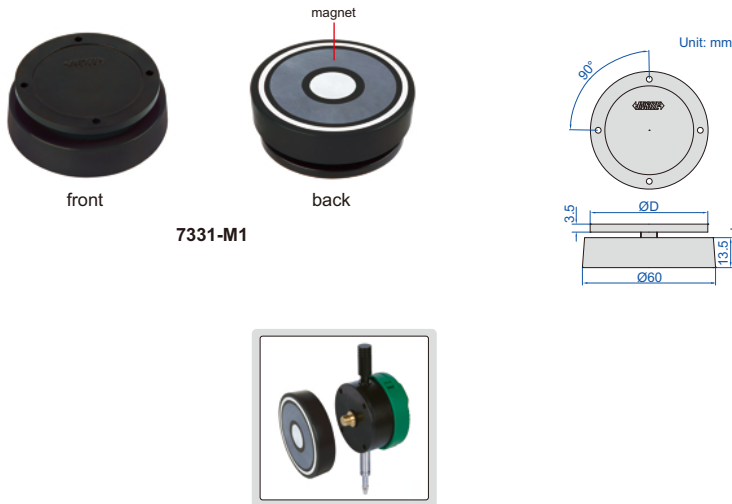

Code	ØD	For digital/dial indicators
7331-M1	51.5mm	2103
		2104
		2108
		2109
		2112
		2115
		2116
		2117
		2118
		2138
		2301
		2302
		2308
		2309
2313		
2314		
2316		
2801		

DIGITAL LINEAR GAGES



IP43
WATERPROOF

ABSOLUTE ENCODER, THE ORIGINAL
DATA REMAINS AFTER POWER OFF

- Scale type: optical grating
- Absolute encoder, the original data remains after power off
- Digital signal output, amplifier is not required
- Repeatability: 0.5µm
- Measuring force: ≤1.5N
- Dust/waterproof: IP43
- Baud rate: 9600 (can be customized)
- Cable length: 3m (can be customized)



7130-10

7130-10L

Code	Range	Resolution	Accuracy	Outgoing cable direction	Output signal	Output interface
7130-10	0-12.5mm	0.1µm	1µm	horizontal	RS232, TTL level	
7130-10L	0-12.5mm	0.1µm	1µm	vertical	RS232, TTL level	

CAPACITANCE LINEAR GAGES

IP65
WATERPROOF

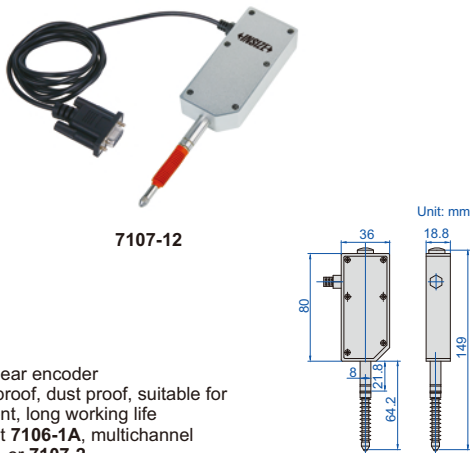

7107-12

- Capacitance type linear encoder
- Shock-proof, water proof, dust proof, suitable for high speed movement, long working life
- Optional: display unit 7106-1A, multichannel interface box 7107-1 or 7107-2

SPECIFICATION

Code	7107-11	7107-12
Measuring range	12mm/0.47"	12mm/0.47"
Resolution	0.01mm/0.0004"	0.001mm/0.00004"
Accuracy	20µm	5µm
Hysteresis	10µm	2µm
Driving type	spring	
Measuring force	1.5N	
Measuring principle	capacitance type linear encoder	
Voltage	5V	
Sampling frequency	100 times/sec	
Working life	ten million times	
Dust/waterproof	IP65	
Cable length	2m	
Data output	RS232	

DISPLAY UNIT FOR CAPACITANCE LINEAR GAGES CODE 7106-1A

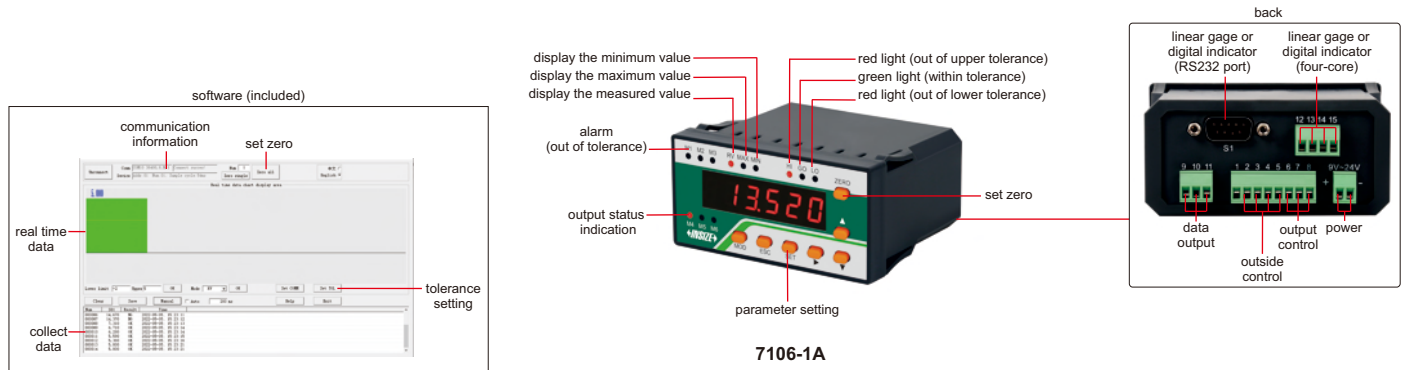

- Can be connected with 7107-11 or 7107-12 linear gage, can also be connected with digital indicator (data cable 7309-C01M is needed)
- Set tolerance and make judgment (out of upper tolerance, within tolerance, out of lower tolerance), output the judgment to control outside devices, control from outside (set zero, hold reading and collect data)
- Software of display unit (included): in the software, it is possible to set tolerance and show judgment (red when out of tolerance, green when within tolerance), set zero, collect data manually or automatically (time is adjustable), output data to Excel, print report

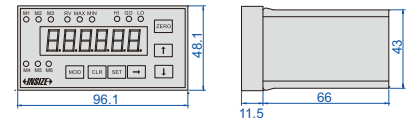

SPECIFICATION

Code	7106-1A
Display	6 digits
Quantity of linear gage or digital indicator to be connected	1 pc
Tolerance	set tolerance and make judgment with alarm and lights (out of upper tolerance, within tolerance, out of lower tolerance)
Output control	output the tolerance judgment (out of upper tolerance, within tolerance, out of lower tolerance) to control outside devices
Outside control	control the display units from outside (set zero, hold reading and collect data)
Data output	connect to computer software and serial communication
Power supply	DC 9~24V

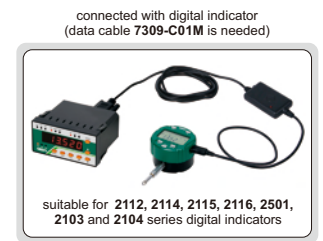

MULTICHANNEL INTERFACE BOXES FOR CAPACITANCE LINEAR GAGES

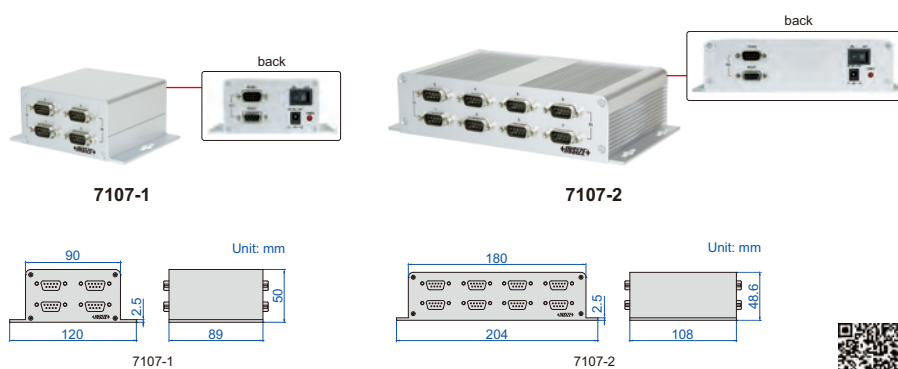

- Can be connected with 7107-11 or 7107-12 linear gages, can also be connected with digital indicators (data cable 7309-C01M is needed)
- Software of interface boxes (included): in the software, it is possible to set tolerance of each channel and show judgment (red when out of tolerance, green when within tolerance), set zero, collect data manually or automatically (time is adjustable), output data to Excel, print report

SPECIFICATION

Code	7107-1	7107-2
Quantity of linear gages or digital indicators to be connected	4 pcs	8 pcs
Data output	RS232 and RS485	
Power supply	DC 9~24V	

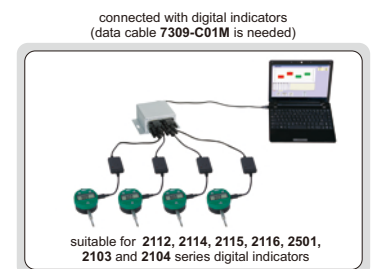
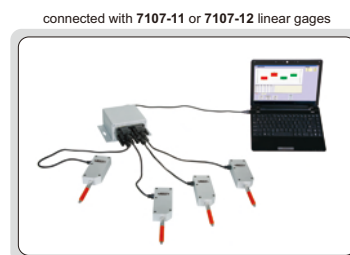
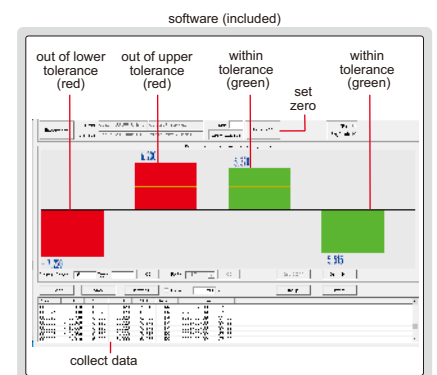

DIAL TEST INDICATOR HOLDER



6291-1

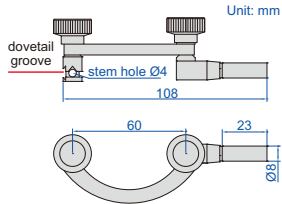

- Can be used with dial test indicators

Code

6291-1

DIAL TEST INDICATOR UNIVERSAL HOLDER



6297-1

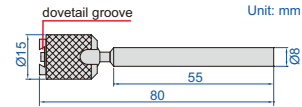

- Set the indicators at the desired attitude to the workpiece

Code

6297-1

DIAL TEST INDICATOR HOLDER



6296-1

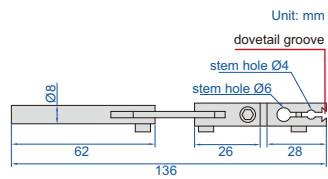

- Supplied with hex key

Code

6296-1

DIAL TEST INDICATOR HOLDERS

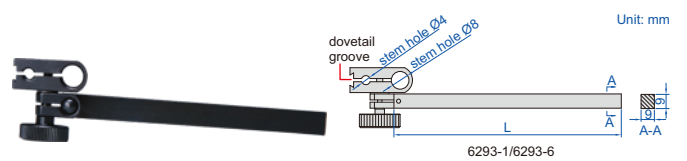

6293-1

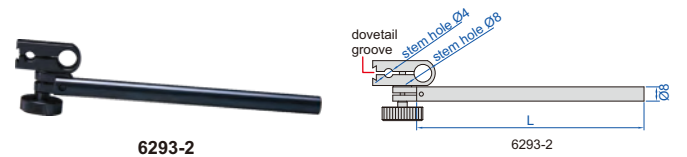

6293-2

Code	Stem section	Stem length (L)
6293-1	9x9mm	100mm
6293-6	9x9mm	50mm
6293-2	Ø8mm	115mm



DIAL TEST INDICATOR HOLDER

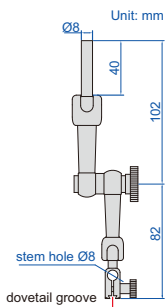

6295-1A

- Can be used with dial test indicators

Code

6295-1A

DIAL INDICATOR HOLDER

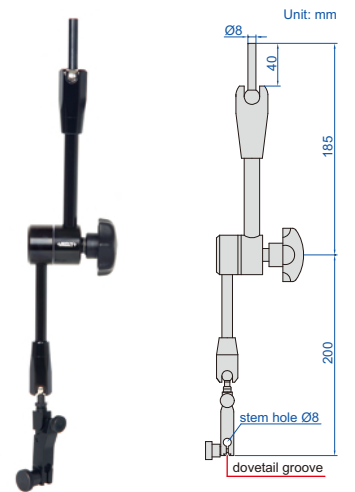

6294-1A

- Can be used with dial test indicators or dial indicators

Code

6294-1A

HYDRAULIC UNIVERSAL MAGNETIC STANDS



6229-60



6229-80



6229-100



6229-101

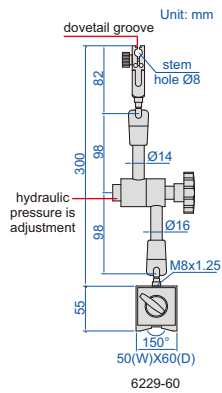

6229-60

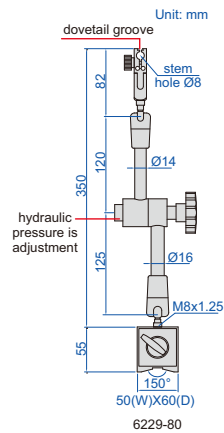

6229-80

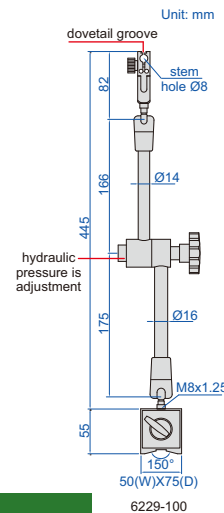

6229-100

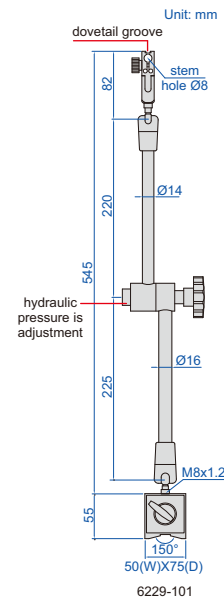

6229-101

- Hydraulic pressure is adjustment
- For digital/dial indicators and dial test indicators

Code	Magnetic force	Applicable holding stem	Remark
6229-60	60kgf	Ø8mm	with fine adjustment and dovetail groove
6229-80	80kgf	Ø8mm	with fine adjustment and dovetail groove
6229-100	100kgf	Ø8mm	with fine adjustment and dovetail groove
6229-101	100kgf	Ø8mm	with fine adjustment and dovetail groove

UNIVERSAL MAGNETIC STANDS

POPULAR MODEL

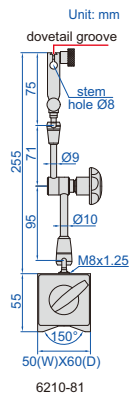

6210-81



6210-81

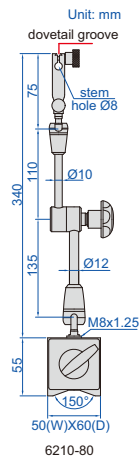

6210-80



6210-80

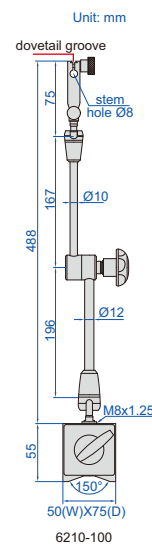

6210-100



6210-100

- For digital/dial indicators and dial test indicators
- With fine adjustment and dovetail groove

Code	Magnetic force	Applicable holding stem
6210-81	80kgf	Ø8mm
6210-80	80kgf	Ø8mm
6210-100	100kgf	Ø8mm

LARGE LOCKING FORCE MAGNETIC STAND



6219-80

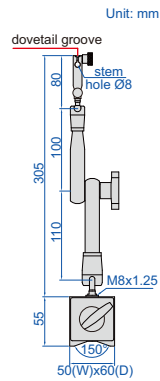

- Applicable holding stem: Ø8mm
- For digital/dial indicators and dial test indicators
- With fine adjustment and dovetail groove

Code	Magnetic force
6219-80	80kgf

UNIVERSAL MAGNETIC STAND (ECONOMIC TYPE)

ATTENTION: LOW LOCKING FORCE



6208-80A

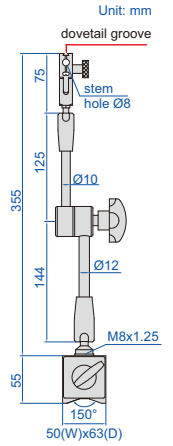

- Applicable holding stem: Ø8mm
- For digital/dial indicators and dial test indicators
- With fine adjustment and dovetail groove

Code	Magnetic force
6208-80A	80kgf

MAGNETIC STAND WITH TWO FINE ADJUSTMENTS

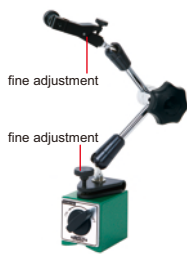

6272-80

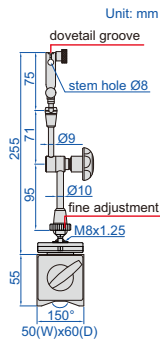

- Magnetic force: 80kgf
- With two fine adjustments on the head and on the base
- For digital/dial indicators and dial test indicators
- With two fine adjustments and dovetail groove

Code	Applicable holding stem
6272-80	Ø8mm

HYDRAULIC MINI MAGNETIC STAND

ATTENTION: FOR DIAL TEST INDICATORS ONLY



6228-40

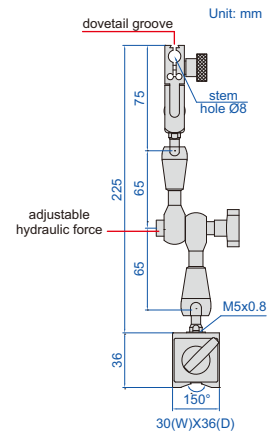

- For dial test indicators
- With fine adjustment and dovetail groove
- Adjustable hydraulic force
- Applicable holding stem: Ø8mm

Code	Magnetic force
6228-40	40kgf

MINI MAGNETIC STAND

ATTENTION: FOR DIAL TEST INDICATORS ONLY



6224-40

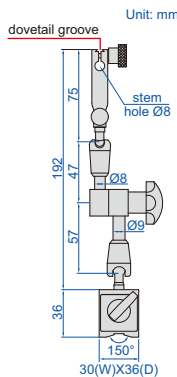

- For dial test indicators
- With fine adjustment and dovetail groove
- Applicable holding stem: Ø8mm

Code	Magnetic force
6224-40	40kgf

MAGNETIC STAND (FOR 0.001MM DIAL AND TEST INDICATORS)



6221-80

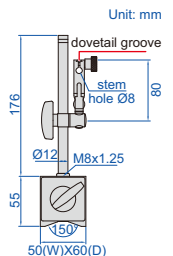

- Applicable holding stem: Ø8mm
- For 0.001mm and 0.01mm dial and test indicators
- With fine adjustment and dovetail groove

Code	Magnetic force
6221-80	80kgf

MAGNETIC STANDS

POPULAR MODEL

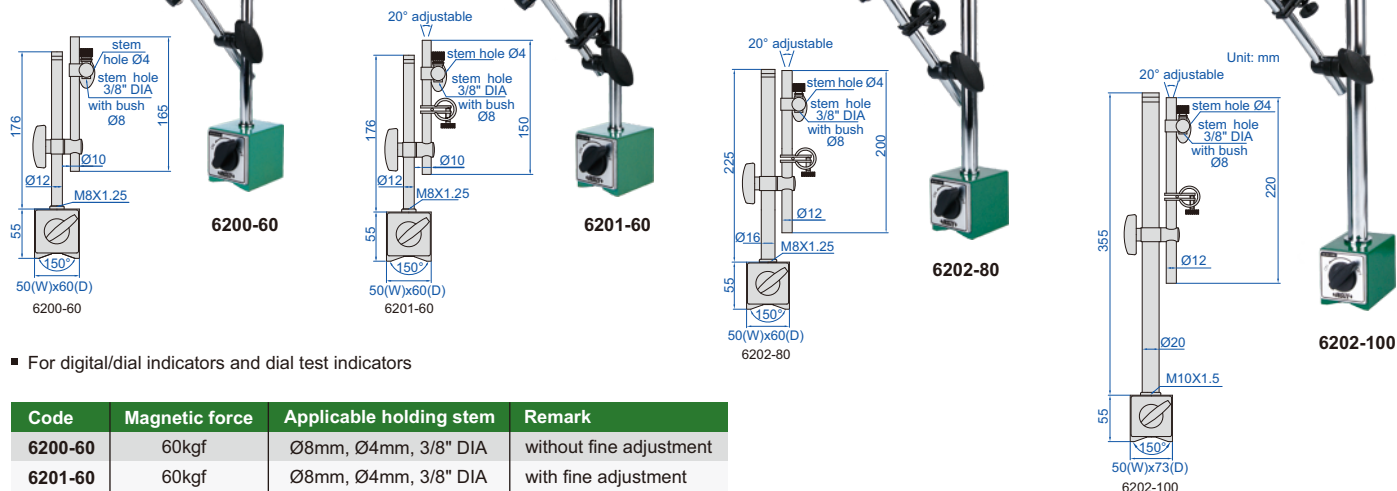

- For digital/dial indicators and dial test indicators

Code	Magnetic force	Applicable holding stem	Remark
6200-60	60kgf	Ø8mm, Ø4mm, 3/8" DIA	without fine adjustment
6201-60	60kgf	Ø8mm, Ø4mm, 3/8" DIA	with fine adjustment
6202-80	80kgf	Ø8mm, Ø4mm, 3/8" DIA	with fine adjustment
6202-100	100kgf	Ø8mm, Ø4mm, 3/8" DIA	with fine adjustment

MAGNETIC STAND

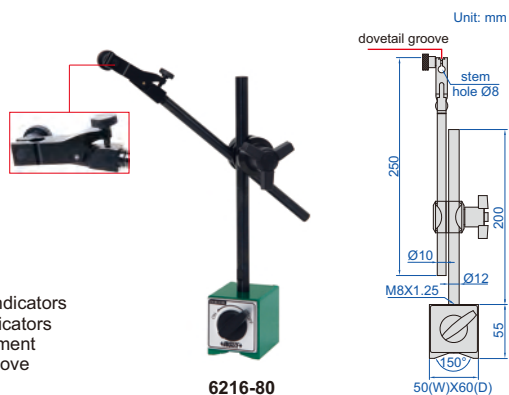

- For digital/dial indicators and dial test indicators
- With fine adjustment and dovetail groove

Code	Magnetic force	Applicable holding stem
6216-80	80kgf	Ø8mm

FLEX ARM MAGNETIC STAND

ATTENTION: FOR DIAL TEST INDICATORS ONLY

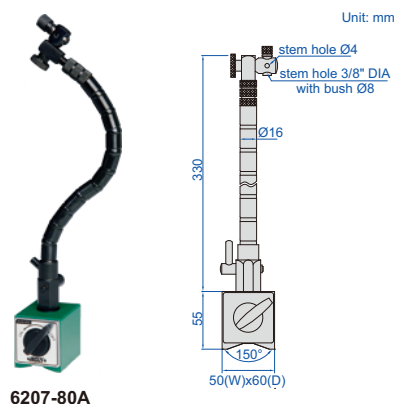

- For dial test indicators
- Applicable holding stem: Ø8mm, Ø4mm, 3/8" DIA.

Code	Magnetic force
6207-80A	80kgf

MINI MAGNETIC STAND

ATTENTION: FOR DIAL TEST INDICATORS ONLY

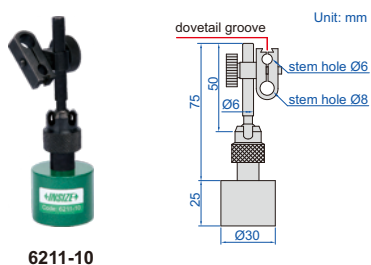

- For dial test indicators
- With dovetail groove
- Applicable holding stem: Ø6mm, Ø8mm

Code	Magnetic force
6211-10	10kgf

DIAL INDICATOR STAND (FOR 0.001MM DIAL AND TEST INDICATORS)

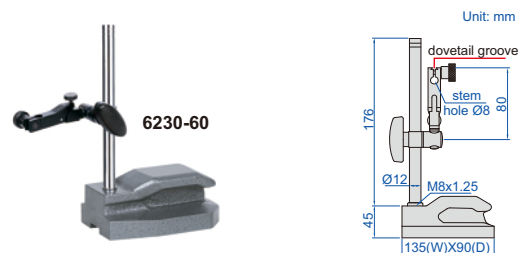

- Non-magnetic and hardened base
- Suitable for granite surface plates or cast iron surface plates
- For 0.001mm and 0.01mm dial and test indicators
- With fine adjustment and dovetail groove

Code	Applicable holding stem
6230-60	Ø8mm

DIAL INDICATOR STANDS (NON-MAGNETIC)

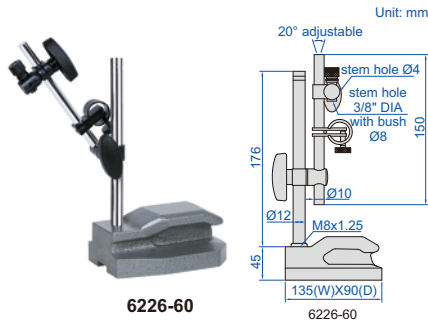

6226-60

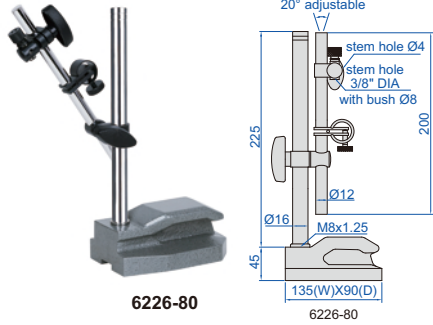

6226-80

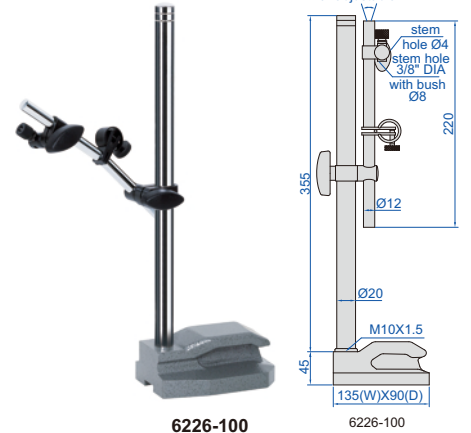

6226-100

Code	Applicable holding stem	Remark
6226-60	Ø8mm, Ø4mm, 3/8" DIA	with fine adjustment
6226-80	Ø8mm, Ø4mm, 3/8" DIA	with fine adjustment
6226-100	Ø8mm, Ø4mm, 3/8" DIA	with fine adjustment

- Hardened base
- Suitable for granite surface plates and cast iron surface plates
- For digital/dial indicators and dial test indicators

DIAL INDICATOR STAND (NON-MAGNETIC)

- Hardened base
- Suitable for granite surface plates and cast iron surface plates
- For digital/dial indicators and dial test indicators
- With fine adjustment and dovetail groove

Code	Applicable holding stem
6227-80	Ø8mm



6227-80

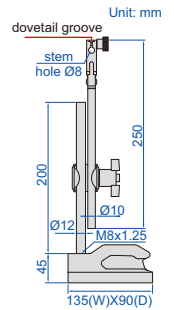

UNIVERSAL DIAL INDICATOR STANDS (NON-MAGNETIC)

- Hardened base
- Suitable for granite surface plates and cast iron surface plates
- For digital/dial indicators and dial test indicators

Code	Applicable holding stem	Remark
6225-80	Ø8mm	with fine adjustment and dovetail groove
6225-100	Ø8mm	with fine adjustment and dovetail groove

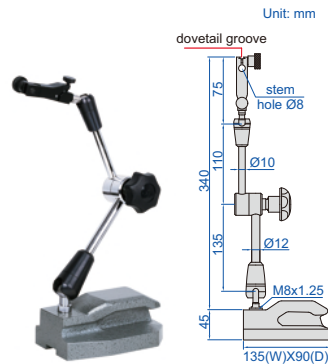

6225-80

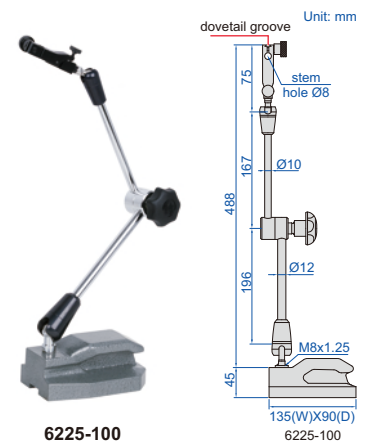

6225-100

DIAL INDICATOR STANDS

- Vertical travel of holder: 150mm
- Applicable holding stem: Ø8mm
- Ceramic anvil
- Supplied with dust cover

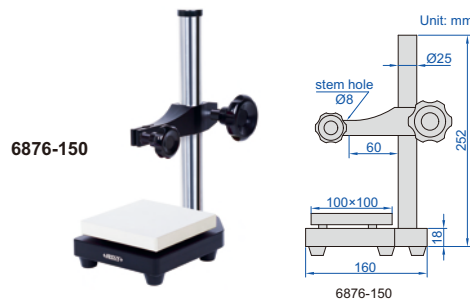

6876-150

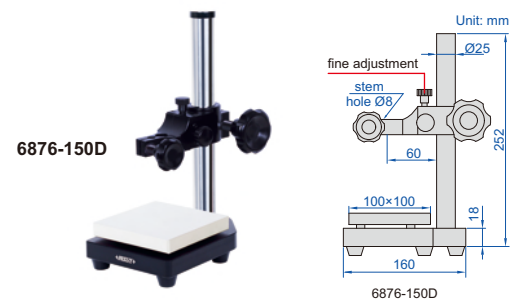

6876-150D

Code	Anvil	Remark
6876-150	ceramic, plain, flatness 1.5µm	without fine adjustment
6876-150D	ceramic, plain, flatness 1.5µm	with fine adjustment, fine adjustment range 3mm

GRANITE DIAL INDICATOR STANDS (BASIC TYPE)

POPULAR MODEL

- Vertical travel of holder: 170mm
- Applicable holding stem: Ø8mm
- Supplied with dust cover

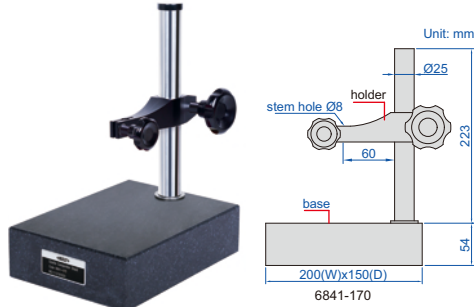

6841-170

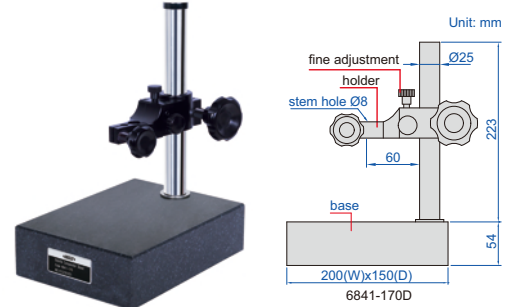

6841-170D

Code	Base	Remark
6841-170	flatness 2.5µm	without fine adjustment
6841-170D	flatness 2.5µm	with fine adjustment, fine adjustment range 3mm

DIAL INDICATOR STAND

GAGE BLOCKS ARE NEEDED FOR ZERO SETTING

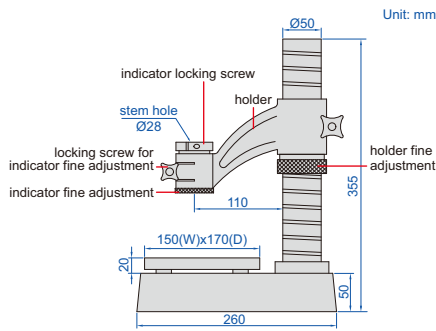

digital/dial indicator is optional



6846-140

- Vertical travel of holder: 140mm
- Holder fine adjustment range: entire stroke
- Indicator fine adjustment range: 3mm
- Optional accessory: Ø28mm/Ø8mm bush (code 6843-B8), 0.001mm digital/dial indicators, high precision digital indicators (code 2140-6, 2140-6WL), gage blocks (4101 series, for zero setting)

Code	Applicable holding stem	Anvil
6846-140	Ø28mm	grid, flatness 1µm

locating fork for workpieces (included)



Ø28mm/Ø8mm bush (optional)

Code
6843-B8



application



DIAL INDICATOR STAND

GAGE BLOCKS ARE NEEDED FOR ZERO SETTING

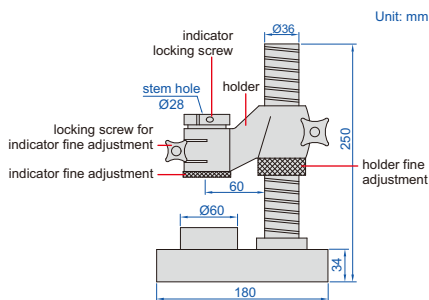

digital/dial indicator is optional



6845-100

- Vertical travel of holder: 100mm
- Holder fine adjustment range: entire stroke
- Indicator fine adjustment range: 3mm
- Optional accessory: Ø28mm/Ø8mm bush (code 6843-B8), 0.001mm digital/dial indicators, high precision digital indicators (code 2140-6, 2140-6WL), gage blocks (4101 series, for zero setting)

Code	Applicable holding stem	Anvil
6845-100	Ø28mm	serrated, flatness 1µm

locating fork for workpieces (included)



Ø28mm/Ø8mm bush (optional)

Code
6843-B8



application



12

INDICATING MEASURING INSTRUMENTS



Internal Caliper Gages
Page 91-92

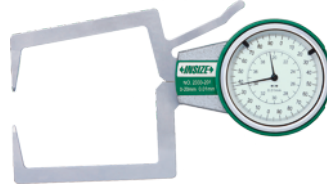

External Caliper Gages
Page 92-93



Thickness Gages
Page 93-95

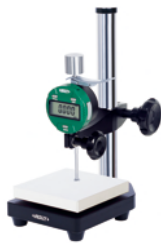

Rubber Thickness Gages
Page 95



Tube Thickness Gages
Page 96



Snap Gages
Page 96



Step And Gap Gages
Page 96



Mini Digital Height Gages
Page 97



Dial Height Gages
Page 97

INTERNAL DIAL CALIPER GAGES



2222-15

- Graduation: 0.01mm
- Accuracy: ±0.03mm

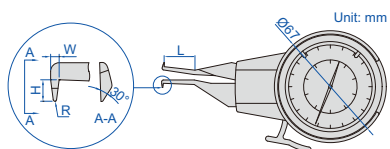

Code	Range	L	H	W	R
2222-15	5-15mm	20mm	2mm	1.5mm	R0.3mm
2222-25	5-25mm	35mm	1.5mm	1.0mm	R0.3mm
2222-301	10-30mm	55mm	5.5mm	2.5mm	R0.5mm

INTERNAL DIAL CALIPER GAGES



2321-35

- Graduation: 0.01mm
- Accuracy: ±0.04mm
- Carbide measuring tips

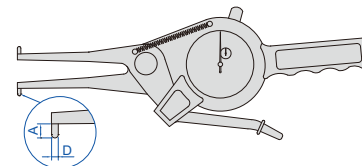

Code	Range	L	A	D
2321-35	15-35mm	<50mm	3mm	Ø3mm
2321-AL35	15-35mm	<200mm	3mm	Ø3mm
2321-55	35-55mm	<80mm	6mm	Ø3mm
2321-AL55	35-55mm	<250mm	8mm	Ø3mm
2321-75	55-75mm	<90mm	8mm	Ø3mm
2321-AL75	55-75mm	<250mm	8mm	Ø3mm
2321-95	75-95mm	<100mm	8mm	Ø3mm
2321-115	95-115mm	<120mm	10mm	Ø3.2mm
2321-135	115-135mm	<120mm	10mm	Ø3.2mm

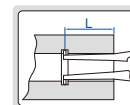

INTERNAL DIAL CALIPER GAGES WITH INTERCHANGEABLE POINTS



2223-153

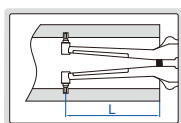
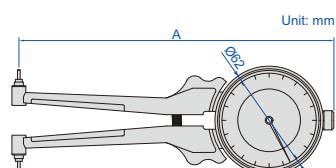

- Graduation: 0.01mm

2223-35 points (included)

Unit: mm

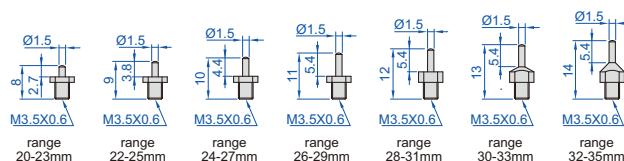
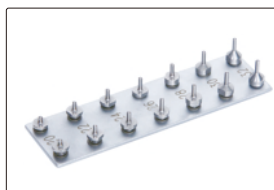

2223-62 points (included)

Unit: mm

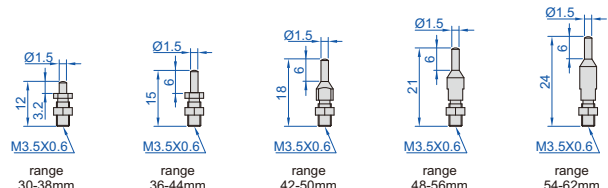
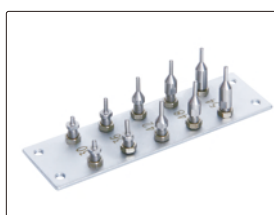

2223-153 points (included)

Unit: mm

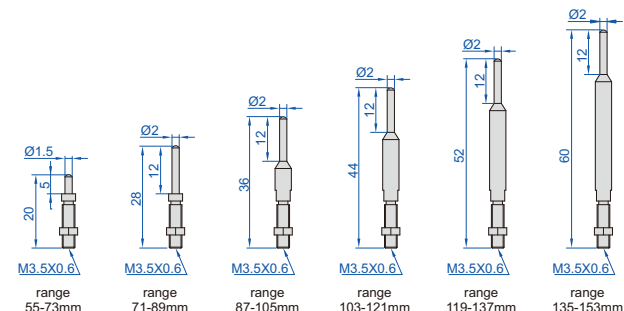

Code	Range	Dial indicator range	Accuracy	A	L	Remark
2223-35	20-35mm	2mm	±0.02mm	164mm	<70mm	supplied with 7 pairs of points
2223-62	30-62mm	2mm	±0.02mm	170mm	<75mm	supplied with 5 pairs of points
2223-153	55-153mm	2mm	±0.02mm	179mm	<90mm	supplied with 6 pairs of points

DIGITAL INTERNAL CALIPER GAGES (ECONOMIC TYPE)

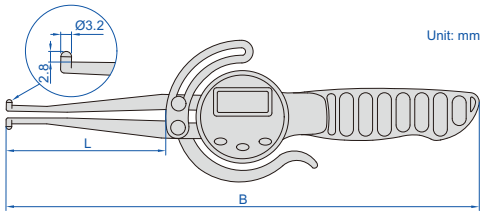

2711-165

- Resolution: 0.1mm/0.01"
- Accuracy: ± 0.3 mm
- Repeatability: 0.2mm
- Button function: on/off, zero, mm/inch, data hold
- Battery CR2032, automatic power off

Code	Range	L	B
2711-165	12.7-165mm/0.5-6.5"	85mm	252mm
2711-216	12.7-216mm/0.5-8.5"	160mm	327mm

sizes to be measured

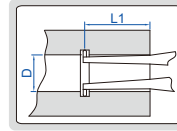

Code 2711-165 (mm)		Code 2711-216 (mm)	
D	L1	D	L1
Ø13	<42	Ø13	<50
Ø15	<45	Ø15	<55
Ø17	<50	Ø17	<60
Ø20	<60	Ø20	<65
Ø25	<75	Ø25	<75
Ø27	<80	Ø30	<95
Ø29-165	<85	Ø35-216	<160

LARGE RANGE INTERNAL DIAL CALIPER GAGES



2334-155

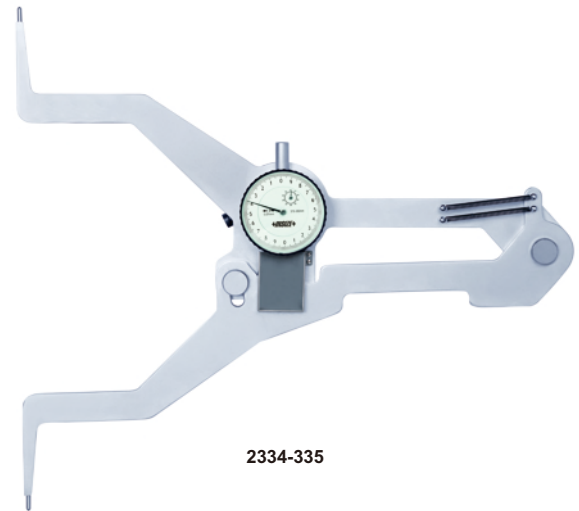

2334-335

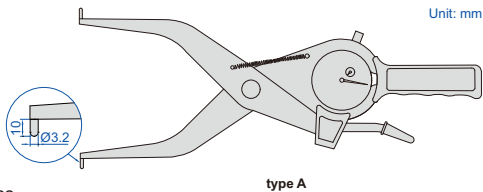

type A

- Carbide measuring tips

Code	Range	Graduation	Accuracy	Type	L
2334-155	135-155mm	0.01mm	± 0.04 mm	A	<200mm
2334-175	155-175mm	0.01mm	± 0.04 mm	A	<200mm
2334-195	175-195mm	0.01mm	± 0.04 mm	A	<200mm
2334-215	195-215mm	0.01mm	± 0.04 mm	A	<200mm
2334-235	215-235mm	0.01mm	± 0.04 mm	A	<200mm
2334-255	235-255mm	0.01mm	± 0.04 mm	A	<200mm
2334-275	255-275mm	0.01mm	± 0.04 mm	A	<200mm
2334-295	275-295mm	0.01mm	± 0.04 mm	A	<200mm
2334-315	295-315mm	0.01mm	± 0.04 mm	A	<200mm
2334-335	315-335mm	0.01mm	± 0.04 mm	B	<200mm
2334-355	335-355mm	0.01mm	± 0.04 mm	B	<200mm
2334-375	355-375mm	0.01mm	± 0.04 mm	B	<200mm

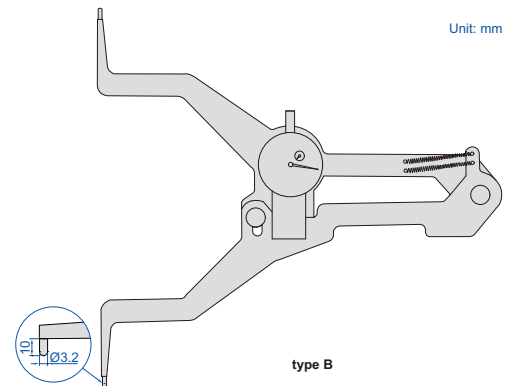
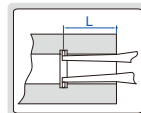

type B

EXTERNAL DIAL CALIPER GAGES

- Graduation: 0.01mm
- Accuracy: ± 0.3 mm

Code	Range
2333-201	0-20mm
2333-301	10-30mm
2333-401	20-40mm



2333-201

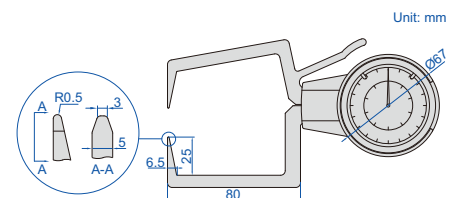

EXTERNAL DIAL CALIPER GAGES



2332-20

Unit: mm

- Accuracy: $\pm 0.04\text{mm}$
- Carbide measuring tips

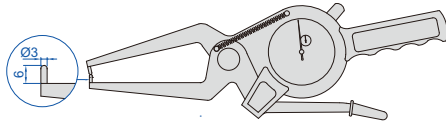

Code	Range	Graduation	L
2332-20	0-20mm	0.01mm	<60mm
2332-40	20-40mm	0.01mm	<60mm
2332-60	40-60mm	0.01mm	<55mm
2332-80	60-80mm	0.01mm	<55mm
2332-100	80-100mm	0.01mm	<55mm

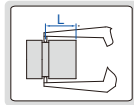

THICKNESS GAGES



2364-10



2364-1

Unit: mm

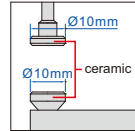

(mm)

Code	Range	Graduation	Accuracy	$\varnothing D$
2364-10	0-10mm	0.01mm	$\pm 0.02\text{mm}$	58
2364-1	0-1mm	0.001mm	$\pm 0.005\text{mm}$	56

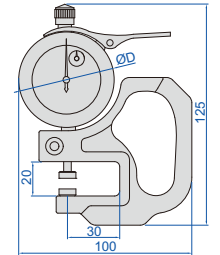

DIGITAL THICKNESS GAGES

POPULAR MODEL

DATA OUTPUT

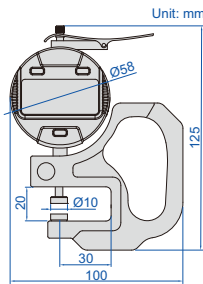

Unit: mm



2871-101

- Ceramic spindle tip and anvil
- Button function: on/off, inch/mm, zero, data preset, change measuring direction, absolute/incremental measurement
- Keep preset data in memory after restart
- CR2032 battery, automatic power off (time is adjustable)
- Data output
- Optional accessory: data output cable (code 7315-50M receiver is needed, 7302-50M)

Code	Range	Resolution	Accuracy
2871-10	0-10mm/0-0.4"	0.01mm/0.0005"	$\pm 0.02\text{mm}$
2871-101	0-10mm/0-0.4"	0.001mm/0.00005"	$\pm 0.005\text{mm}$

DIGITAL THICKNESS GAGES

DATA OUTPUT



2872-10

measuring tips and anvils can be custom-made



Unit: mm

- Ceramic spindle tip and anvil
- Buttons: on/off, inch/mm, zero, data preset, change measuring direction, absolute/incremental measurement
- Keep preset data in memory after restart
- Battery CR2032, data output
- Automatic power off (time is adjustable)
- Optional accessory: data output cable (code 7315-50M receiver is needed, 7302-50M)

Code	Range	Resolution	Accuracy
2872-10	0-10mm/0-0.4"	0.01mm/0.0005"	$\pm 0.02\text{mm}$
2872-101	0-10mm/0-0.4"	0.001mm/0.00005"	$\pm 0.01\text{mm}$

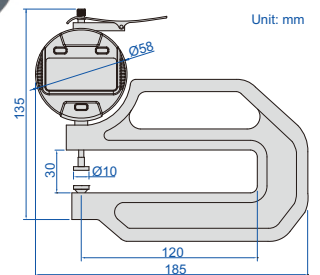

THICKNESS GAGES

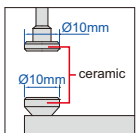

Unit: mm

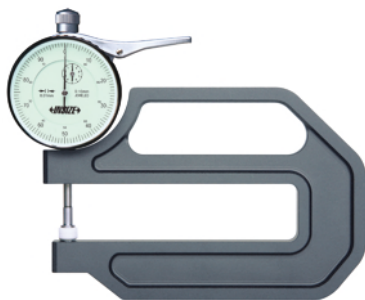

2365-10

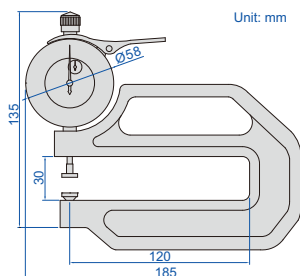

measuring tips and anvils can be custom-made



Code	Range	Graduation	Accuracy
2365-10	0-10mm	0.01mm	$\pm 0.02\text{mm}$
2365-20	0-20mm	0.01mm	$\pm 0.03\text{mm}$

THICKNESS GAGE

SUITABLE FOR JEWELLERY

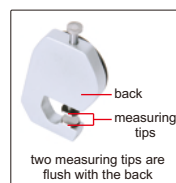

two measuring tips are flush with the back



2361-10

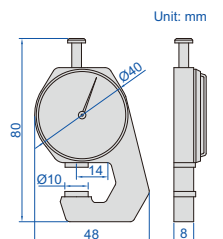

Unit: mm

Code	Range	Graduation	Accuracy
2361-10	0-10mm	0.1mm	$\pm 0.05\text{mm}$

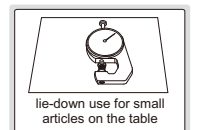

DIGITAL ROLLER THICKNESS GAGE

DATA OUTPUT

- Resolution: 0.01mm/0.0005"
- Buttons: on/off, inch/mm, zero, data preset, change measuring direction, absolute/incremental measurement
- Keep preset data in memory after restart
- Battery CR2032, data output
- Automatic power off (time is adjustable)
- Optional accessory: data output cable (code 7315-50M receiver is needed, 7302-50M)

Code	Range	Accuracy
2877-4	0-3.5mm/0-0.14"	±0.02mm

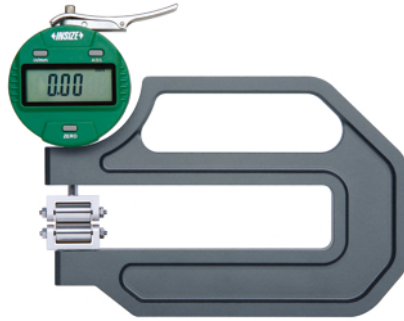

2877-4

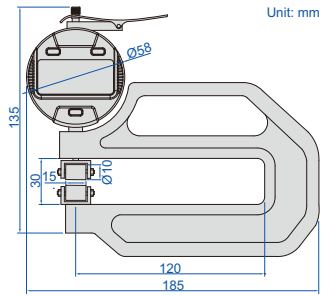

HIGH PRECISION DIGITAL THICKNESS GAGES

ATTENTION: RECHARGEABLE BATTERY, FOR 12 HOURS CONTINUOUS WORKING

ABSOLUTE ENCODER, THE ORIGINAL DATA REMAINS AFTER POWER OFF

MEASURING TIPS AND ANVILS CAN BE CUSTOM-MADE

DATA OUTPUT



2879-10



2879-30



2879-60

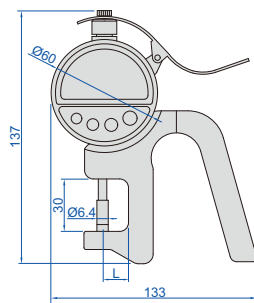

2879-10
2879-101

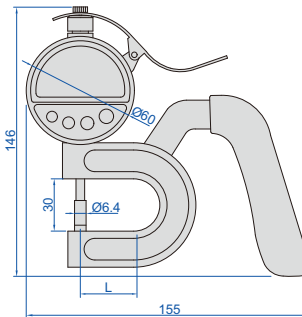

2879-30

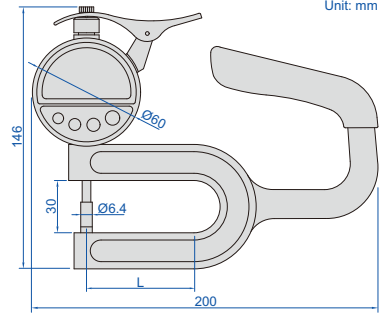

2879-60
2879-100

Unit: mm

- Absolute encoder, the original data remains after power off
- Button function: on/off, zero, tolerance, absolute/incremental measurement, max./min./TIR, data preset, mm/inch, data output, data hold
- Measuring force: 0.5-1N
- Reading in digital and analog
- Power: rechargeable battery, for 12 hours continuous working
- Data output
- Supplied with data output cable (keyboard format)

Code	Range	Resolution	Accuracy	Repeatability	L
2879-10	0-10mm/0-0.4"	0.001mm/0.00005"	±0.002mm	0.001mm	15mm
2879-101	0-10mm/0-0.4"	0.0005mm/0.00002"	±0.0015mm	0.0005mm	15mm
2879-30	0-10mm/0-0.4"	0.001mm/0.00005"	±0.002mm	0.001mm	30mm
2879-60	0-10mm/0-0.4"	0.001mm/0.00005"	±0.003mm	0.001mm	60mm
2879-100	0-10mm/0-0.4"	0.001mm/0.00005"	±0.004mm	0.001mm	100mm

THICKNESS GAGE

- Graduation: 0.01mm
- Stainless steel spindle tip and anvil



2363-10

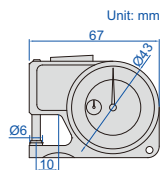

Code	Range	Accuracy
2363-10	0-10mm	±0.03mm

THICKNESS GAGE WITH POINTED TIPS

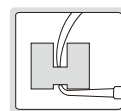

2866-10

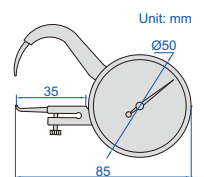

- Graduation: 0.05mm
- Pointed tips fit into small grooves and recesses

Code	Range	Accuracy
2866-10	0-10mm	±0.1mm

THICKNESS GAGES



2862-101

Code	Range	Graduation	Accuracy	L	L1
2862-101	0-10mm	0.05mm	±0.1mm	35mm	85mm
2862-102	0-10mm	0.05mm	±0.1mm	60mm	110mm

THICKNESS GAGE

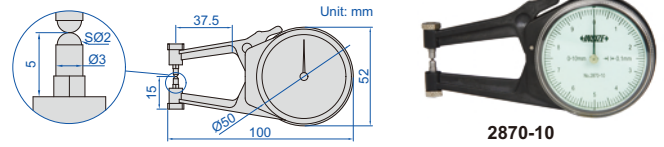

2870-10

- Graduation: 0.1mm
- Main baby is made of hard plastic

Code	Range	Accuracy
2870-10	0-10mm	±0.1mm

THICKNESS GAGE



2863-10

Code	Range	Graduation	Accuracy
2863-10	0-10mm	0.05mm	±0.1mm

DIGITAL THICKNESS GAGE

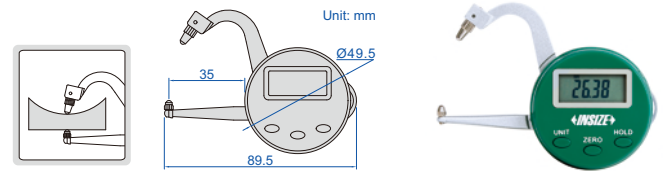

2710-25

- Resolution: 0.01mm, 0.001", 1/64"
- Repeatability: 0.02mm
- Buttons: on/off, zero, unit (mm/in/fraction), data hold
- Battery CR2032
- Automatic power off

Code	Range	Accuracy
2710-25	0-25.4mm/0-1"	0.05mm

DIGITAL RUBBER THICKNESS GAGES

DATA OUTPUT



2878-6B

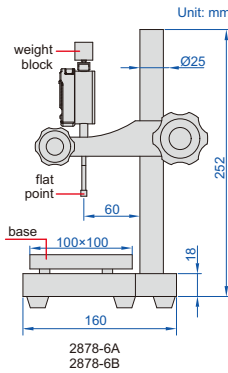

2878-6A
2878-6B



2878-71B

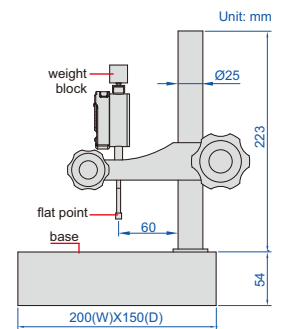

2878-71A
2878-71B

- Flat point diameter: 6mm
- Measure thickness of vulcanized rubber and plastic products
- Button function: on/off, inch/mm, zero, data preset, change measuring direction, absolute/incremental measurement
- CR2032 battery, automatic power off (time is adjustable)
- Supplied with dust cover
- Optional accessory: data output cable (code 7315-50M receiver is needed, 7302-50M), flat points, weight blocks

Code	Range	Resolution	Accuracy	Pressure	Base
2878-6A	12.7mm/0.5"	0.01mm/0.0005"	20µm	22KPa±5KPa	ceramic, plain, flatness 1.5µm
2878-6B	12.7mm/0.5"	0.001mm/0.00005"	5µm	22KPa±5KPa	ceramic, plain, flatness 1.5µm
2878-71A	12.7mm/0.5"	0.01mm/0.0005"	20µm	22KPa±5KPa	granite, plain, flatness 2.5µm
2878-71B	12.7mm/0.5"	0.001mm/0.00005"	5µm	22KPa±5KPa	granite, plain, flatness 2.5µm

Flat points and weight blocks (optional)

Flat point	Flat point code	Pressure				
		10KPa±2KPa weight block code	22KPa±5KPa weight block code	20KPa±3KPa weight block code	70KPa±5KPa weight block code	1.6KPa±0.1KPa weight block code
Ø4mm	2878-P4	—	2878-W4B	—	—	—
Ø5mm	2878-P5	2878-W5A	2878-W5B	2878-W5C	2878-W5D	—
Ø6mm	2878-P6	2878-W6A	2878-W6B	—	—	—
Ø8mm	2878-P8	2878-W8A	2878-W8B	—	—	—
Ø10mm	2878-P10	2878-W10A	2878-W10B	2878-W10C	—	—
Ø25mm	2878-P25	—	—	—	—	2878-W25E
1x4mm (rectangle)	2878-P14	—	—	—	2878-W14D	—

DIGITAL TUBE THICKNESS GAGE

DATA OUTPUT

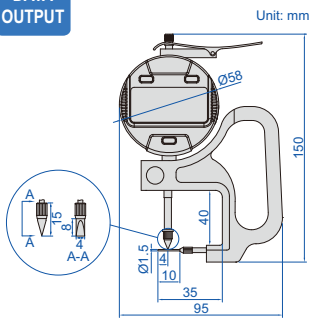

2873-10

- Buttons: on/off, inch/mm, zero, data preset, change measuring direction, absolute/incremental measurement
- Keep preset data in memory after restart
- Battery CR2032, automatic power off (time is adjustable)
- Data output
- Optional accessory: data output cable (code 7315-50M receiver is needed, 7302-50M)

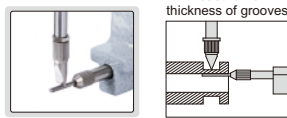

Code	Range	Resolution	Accuracy
2873-10	0-10mm/0-0.4"	0.01mm/0.0005"	±0.02mm

DIAL SNAP GAGES

ATTENTION: SETTING STANDARDS ARE NOT INCLUDED

IP54 WATERPROOF



3334-25

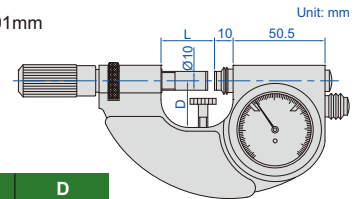

- Quick measurement for mass production
- Dial indicator: range ±0.04mm, graduation 0.001mm, accuracy 0.001mm
- IP54 dust/waterproof
- Measuring force: 5-10N
- Carbide measuring faces
- Optional accessory: gage blocks grade 0 (4101-A series), for zero setting

Code	Range	L	D
3334-25	0-25mm	28.5mm	25mm
3334-50	25-50mm	53.5mm	35mm
3334-75	50-75mm	78.5mm	47.5mm
3334-100	75-100mm	103.5mm	60mm

TUBE THICKNESS GAGE

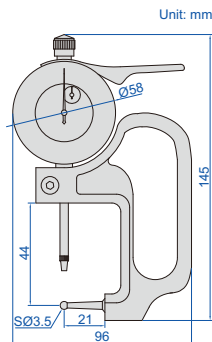

2367-10A

- Graduation: 0.01mm
- Measure tube wall thickness

Code	Range	Accuracy
2367-10A	0-10mm	±0.02mm

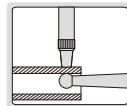

DIGITAL SNAP GAGE

ATTENTION: NO DATA OUTPUT

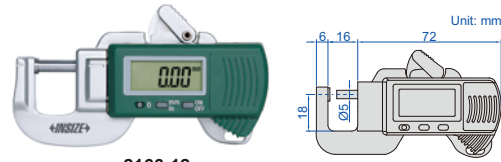

2166-12

Code	Range	Resolution	Accuracy
2166-12	0-12mm/0-0.5"	0.01mm/0.0005"	±0.03mm

DIGITAL 3-PURPOSE SNAP GAGE

ATTENTION: NO DATA OUTPUT

SUITABLE FOR JEWELLERY

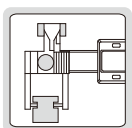

2164-25A

- Non waterproof
- Resolution: 0.01mm/0.0005"
- Buttons: zero, mm/inch, on/off
- Battery LR44
- Made of stainless steel

Code	Range	Accuracy
2164-25A	0-25mm/0-1"	±0.03mm

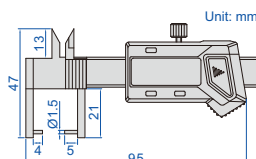

STEP AND GAP GAGE

DATA OUTPUT



front

2168-12

back

- Non waterproof
- Resolution: 0.01mm/0.0005"
- Measure step height and gap width
- Buttons: on/off, set, mm/inch, preset (+, -)
- Automatic power off, move the digital unit to turn on power
- Battery CR2032, data output
- Made of stainless steel
- Supplied with zero setting block
- Optional accessory: data output cable (code 7315-21 receiver is needed, 7302-21)

zero setting block (included)

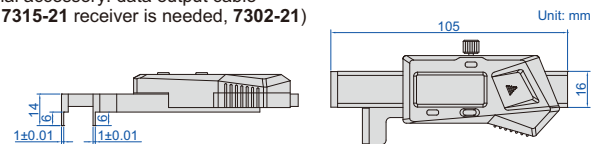

Code	Range	Accuracy
2168-12	0-12.7mm/0-0.5"	±0.03mm

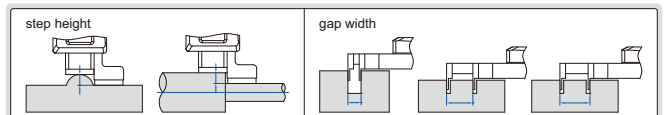

MINI DIGITAL HEIGHT GAGE

DATA OUTPUT

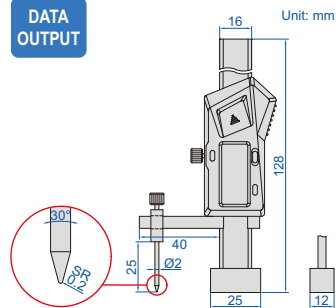

1146-20A

- Non waterproof
- Measure height difference of two surfaces
- Resolution: 0.01mm/0.0005"
- Buttons: on/off, zero, mm/inch
- Automatic power off, move the digital unit to turn on power
- Battery CR2032, data output
- Made of stainless steel
- Optional accessory: data output cable (code 7315-21 receiver is needed, 7302-21)

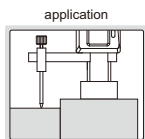

Code	Range	Accuracy
1146-20A	0~±20mm/0~±0.8"	±0.02mm

MINI VERNIER HEIGHT GAGE

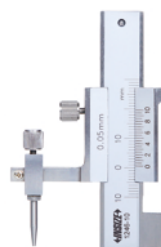

1246-10

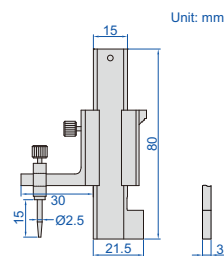

- Measure height difference of two surfaces
- Graduation: 0.05mm
- Made of stainless steel
- Satin chrome plated reading surface

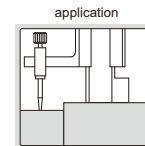

Code	Range	Accuracy
1246-10	0~±10mm	±0.05mm

DIAL HEIGHT GAGES



2147-4A

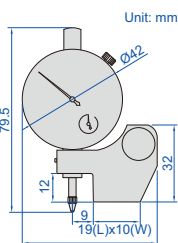

2147-4A



2147-4B

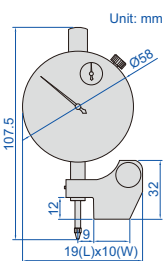

2147-4B



2147-21

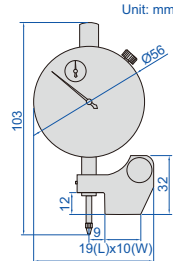

2147-21

- Measure height difference of two surfaces

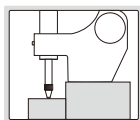

Code	Range	Dial indicator stroke	Dial indicator graduation	Accuracy
2147-4A	0~±5mm (adjustable)	5mm	0.01mm	±0.014mm
2147-4B	0~±5mm	10mm	0.01mm	±0.017mm
2147-21	0~±2mm (adjustable)	2mm	0.001mm	±0.006mm

DIGITAL HEIGHT GAGES

DATA OUTPUT

- Measure height difference of two surfaces
- Button function: on/off, inch/mm, zero, data preset, change measuring direction, absolute/incremental measurement
- Keep preset data in memory after restart
- CR2032 battery, automatic power off (time is adjustable)
- Data output
- Optional accessory: data output cable (code 7315-50M receiver is needed, 7302-40M)



2146-4A

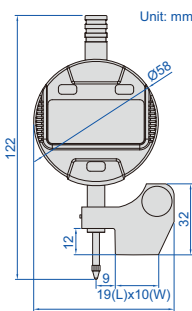

2146-4A
2146-41A



2146-4B

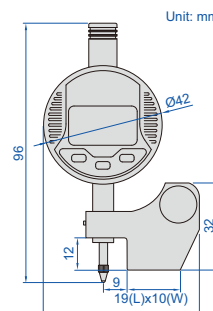

2146-4B
2146-41B

Code	Range (adjustable)	Digital indicator stroke	Digital indicator resolution	Accuracy
2146-4A	0~4mm/0~0.16" (sunked)	12.7mm/0.5"	0.01mm/0.0005"	±0.02mm
2146-41A	0~12.7mm/0~0.5" (raised)	12.7mm/0.5"	0.001mm/0.00005"	±0.005mm
2146-4B	0~4mm/0~0.16" (sunked)	5mm/0.2"	0.01mm/0.0005"	±0.02mm
2146-41B	0~5mm/0~0.2" (raised)	5mm/0.2"	0.001mm/0.00005"	±0.005mm

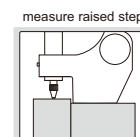
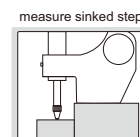

13

STANDARDS AND GAGE BLOCKS



Gage Blocks
Page 99-100



Micrometer Inspection Gage Block Sets
Page 100



Gage Block Holders
Page 100



Pin Gages
Page 101



Pin Gage Handles
Page 101



Setting Rings
Page 102



Measuring Balls
Page 103



Plain Plug Gages
Page 104



Threaded Hole Location Gages
Page 104



Thread Ring Gages
Page 105



Thread Plug Gages
Page 106

CERAMIC GAGE BLOCK SETS

- Made of ceramic, extremely wear resistance and corrosion resistance, excellent dimension stability
- Meet ISO3650
- Supplied with manufacturer inspection certificate



4105-87

Blocks per set	Gage blocks included in set			Code	
	Size (mm)	Step (mm)	Quantity	Grade 0	Grade 1
87	1.001-1.009	0.001	9	4105-87	4105-187
	1.01-1.49	0.01	49		
	0.5-9.5	0.5	19		
	10-100	10	10		
32	1.005	0.01	1	4105-32	4105-132
	1.01-1.09		9		
	1.1-1.9		9		
	1-9		9		
	10-30		3		
	50		1		

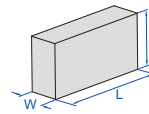

Dimension:

Size (L)	W	H
0.5 ≤ L ≤ 10mm	9mm	30mm
L > 10mm	9mm	35mm

STEEL GAGE BLOCK SETS

- Made of alloy steel
- Meet ISO3650
- Gage blocks ≥125mm have clamping holes
- Supplied with manufacturer inspection certificate



4100-187

Blocks per set	Gage blocks included in set			Code	
	Size (mm)	Step (mm)	Quantity	Grade 1	Grade 2
112	1.0005	0.001	1	4100-1112	4100-2112
	1.001-1.009		9		
	1.01-1.49		49		
	0.5-24.5		49		
	25-100		4		
87	1.001-1.009	0.001	9	4100-187	4100-287
	1.01-1.49		49		
	0.5-9.5		19		
	10-100		10		
83	0.5	0.01	1	4100-183	4100-283
	1		1		
	1.005		1		
	1.01-1.49		49		
	1.5-1.9		5		
	2-9.5		16		
10-100	10				
34	1.0005	0.001	1	4100-134	4100-234
	1.001-1.009		9		
	1.01-1.09		9		
	1.1-1.9		9		
	1-5		5		
10	1				

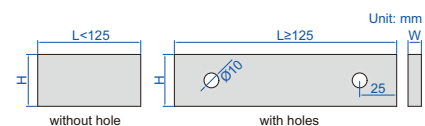

Dimension:

Size (L)	W	H
0.5 ≤ L ≤ 10mm	9mm	30mm
L > 10mm	9mm	35mm

STEEL INDIVIDUAL GAGE BLOCKS

CUSTOM-MADE
CAN SUPPLY ANY SIZES FROM 0.5
TO 1000MM, SUCH AS 72.672MM

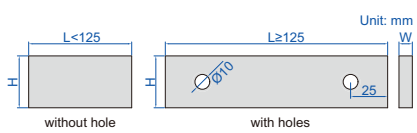

Dimension:

Size (L)	W	H
0.5 ≤ L ≤ 10mm	9mm	30mm
L > 10mm	9mm	35mm

- Grade 1
- Meet ISO3650
- Made of alloy steel
- Gage blocks with clamping holes: 125, 150, 175, 200, 250, 300, 400, 500, 600, 700, 800, 900, 1000mm
- Supplied with manufacturer inspection certificate

Code	Size (mm)	Code	Size (mm)	Code	Size (mm)
4101-BD5	0.5	4101-B1D3	1.3	4101-B8D5	8.5
4101-B1	1	4101-B1D32	1.32	4101-B9	9
4101-B1D001	1.001	4101-B1D33	1.33	4101-B9D5	9.5
4101-B1D002	1.002	4101-B1D34	1.34	4101-B10	10
4101-B1D003	1.003	4101-B1D35	1.35	4101-B11	11
4101-B1D004	1.004	4101-B1D36	1.36	4101-B12	12
4101-B1D005	1.005	4101-B1D37	1.37	4101-B13	13
4101-B1D006	1.006	4101-B1D4	1.4	4101-B14	14
4101-B1D009	1.009	4101-B1D42	1.42	4101-B15	15
4101-B1D01	1.01	4101-B1D43	1.43	4101-B16	16
4101-B1D02	1.02	4101-B1D45	1.45	4101-B18	18
4101-B1D03	1.03	4101-B1D46	1.46	4101-B20	20
4101-B1D04	1.04	4101-B1D47	1.47	4101-B21	21
4101-B1D05	1.05	4101-B1D48	1.48	4101-B22	22
4101-B1D06	1.06	4101-B1D49	1.49	4101-B23	23
4101-B1D07	1.07	4101-B1D5	1.5	4101-B25	25
4101-B1D08	1.08	4101-B1D7	1.7	4101-B30	30
4101-B1D09	1.09	4101-B1D8	1.8	4101-B35	35
4101-B1D1	1.1	4101-B1D9	1.9	4101-B40	40
4101-B1D12	1.12	4101-B2	2	4101-B45	45
4101-B1D15	1.15	4101-B2D5	2.5	4101-B50	50
4101-B1D16	1.16	4101-B3	3	4101-B60	60
4101-B1D18	1.18	4101-B3D5	3.5	4101-B70	70
4101-B1D19	1.19	4101-B4	4	4101-B75	75
4101-B1D2	1.2	4101-B4D5	4.5	4101-B80	80
4101-B1D21	1.21	4101-B5	5	4101-B90	90
4101-B1D22	1.22	4101-B5D5	5.5	4101-B100	100
4101-B1D24	1.24	4101-B6	6	4101-B125	125
4101-B1D25	1.25	4101-B7	7	4101-B131D4	131.4
4101-B1D26	1.26	4101-B7D5	7.5	4101-B150	150
4101-B1D27	1.27	4101-B8	8		

MICROMETER INSPECTION GAGE BLOCK SET

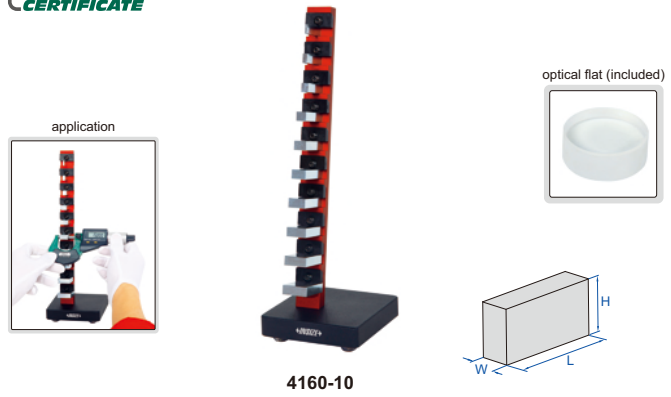

- Meet ISO3650/grade 0
- One piece of optical flat is included (size Ø30x12mm)
- Supplied with manufacturer inspection certificate

Dimension:

Size (L)	W	H
0.5 ≤ L ≤ 10mm	9mm	30mm
L > 10mm	9mm	35mm

Code	Material	Gage blocks included in set	Applicable micrometer
4160-10	alloy steel	2.5mm, 5.1mm, 7.7mm, 10.3mm, 12.9mm, 15mm, 17.6mm, 20.2mm, 22.8mm, 25mm	0-25mm

GAGE BLOCK HOLDER

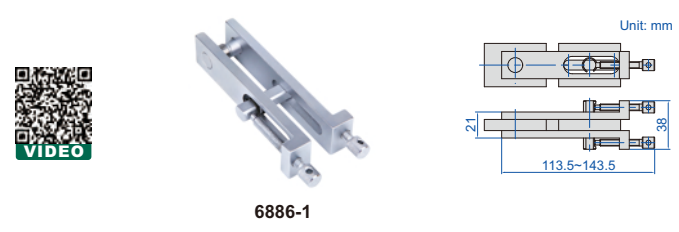

- For gage blocks over 125mm with clamping holes
- Optional accessory: gage block holder accessory, gage block accessory (code 6881)

Code
6886-1

GAGE BLOCK HOLDER ACCESSORY

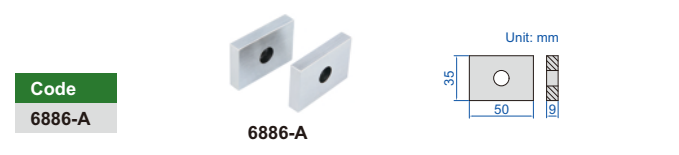

Code
6886-A

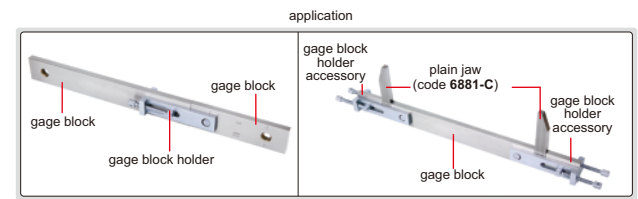

STEEL INDIVIDUAL PIN GAGES WITH TWO DECIMAL PLACES (0.01MM STEP)

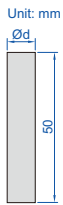

4110-9D98

Ordering examples:

Diameter	Code
0.21mm	4110-0D21
5.56mm	4110-5D56
16.00mm	4110-16D00

Note: "D" stands for "."

- Meet DIN2269, grade 1
- Diameter range: Ø0.20~Ø20.00mm
- Diameter accuracy: ±1µm
- Made of alloy steel
- Hardness HRC62-65

Code
4110-□□□□

Diameter Ød (mm)
0.20, 0.21, 0.22, 0.23, … 1.00
1.01, 1.02, 1.03, 1.04, … 2.00
2.01, 2.02, 2.03, 2.04, … 3.00
3.01, 3.02, 3.03, 3.04, … 4.00
4.01, 4.02, 4.03, 4.04, … 5.00
5.01, 5.02, 5.03, 5.04, … 6.00
6.01, 6.02, 6.03, 6.04, … 7.00
7.01, 7.02, 7.03, 7.04, … 8.00
8.01, 8.02, 8.03, 8.04, … 9.00
9.01, 9.02, 9.03, 9.04, … 10.00
10.01, 10.02, 10.03, 10.04, … 11.00
11.01, 11.02, 11.03, 11.04, … 12.00
12.01, 12.02, 12.03, 12.04, … 13.00
13.01, 13.02, 13.03, 13.04, … 14.00
14.01, 14.02, 14.03, 14.04, … 15.00
15.01, 15.02, 15.03, 15.04, … 16.00
16.01, 16.02, 16.03, 16.04, … 17.00
17.01, 17.02, 17.03, 17.04, … 18.00
18.01, 18.02, 18.03, 18.04, … 19.00
19.01, 19.02, 19.03, 19.04, … 20.00

STEEL INDIVIDUAL PIN GAGES WITH THREE DECIMAL PLACES (0.001MM STEP)

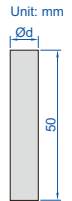

4118-8D015

Ordering examples:

Diameter	Code
0.211mm	4118-0D211
5.562mm	4118-5D562
16.298mm	4118-16D298

Note: "D" stands for "."

- Meet DIN2269, grade 1
- Diameter range: Ø0.200~Ø30.000mm with three decimal, for example 0.211mm, 5.562mm, 16.298mm
- Diameter accuracy: ±1µm
- Made of alloy steel
- Hardness HRC62-65

Code	Diameter range Ød (mm)
4118-□□□□□*	0.200~30.000

*Supplied with manufacturer inspection certificate

STEEL PIN GAGE SETS

POPULAR MODEL

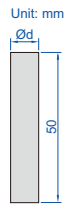

4166-10

- Meet DIN2267, grade 1
- Made of alloy steel
- Hardness HRC62-65
- Diameter accuracy: ±1µm

Code	Diameter Ød (mm)	Step	Pin gages per set
4166-411	1.0, 1.1, 1.2, … 5.0	0.1mm	41
4166-511	5.0, 5.1, 5.2, … 10.0	0.1mm	51

Code	Diameter Ød (mm)	Step	Pin gages per set
4166-0D	0.20, 0.21, 0.22, … 0.50	0.01mm	31
4166-1	0.50, 0.51, 0.52, … 1.00	0.01mm	51
4166-1D	1.00, 1.01, 1.02, … 1.50	0.01mm	51
4166-2	1.50, 1.51, 1.52, … 2.00	0.01mm	51
4166-2D	2.00, 2.01, 2.02, … 2.50	0.01mm	51
4166-3	2.50, 2.51, 2.52, … 3.00	0.01mm	51
4166-3D	3.00, 3.01, 3.02, … 3.50	0.01mm	51
4166-4	3.50, 3.51, 3.52, … 4.00	0.01mm	51
4166-4D	4.00, 4.01, 4.02, … 4.50	0.01mm	51
4166-5	4.50, 4.51, 4.52, … 5.00	0.01mm	51
4166-5D	5.00, 5.01, 5.02, … 5.50	0.01mm	51
4166-6	5.50, 5.51, 5.52, … 6.00	0.01mm	51
4166-6D	6.00, 6.01, 6.02, … 6.50	0.01mm	51
4166-7	6.50, 6.51, 6.52, … 7.00	0.01mm	51
4166-7D	7.00, 7.01, 7.02, … 7.50	0.01mm	51
4166-8	7.50, 7.51, 7.52, … 8.00	0.01mm	51
4166-8D	8.00, 8.01, 8.02, … 8.50	0.01mm	51
4166-9	8.50, 8.51, 8.52, … 9.00	0.01mm	51
4166-9D	9.00, 9.01, 9.02, … 9.50	0.01mm	51
4166-10	9.50, 9.51, 9.52, … 10.00	0.01mm	51

PIN GAGE HANDLES (OPERATED WITHOUT WRENCH)



7342-M1



application



- Operated without wrench
- Made of aluminum
- Pin gages can be installed

Code	Applicable pin gage diameter	H	L
7342-M0	0.3-1.5mm/0.011-0.049"	10mm	112mm
7342-M1	1.51-6.35mm/0.050-0.250"	24mm	131mm
7342-M2	6.36-12.70mm/0.251-0.500"	32mm	152mm
7342-M3	12.71-15.88mm/0.501-0.625"	37mm	152mm
7342-M4	15.89-19.00mm/0.626-0.750"	37mm	152mm
7342-M5	19.01-21.13mm/0.751-0.832"	40mm	158mm
7342-M6	21.14-23.27mm/0.833-0.916"	40mm	158mm
7342-M7	23.28-25.4mm/0.917-1.000"	40mm	158mm

SETTING RINGS



CAN SUPPLY CUSTOM SETTING RINGS FROM Ø1.50MM TO Ø400.00MM, FOR EXAMPLE, Ø17.08MM

- For zero setting of inside micrometers, three points internal micrometers and bore gages
- The size marked on the setting ring is checked at the direction of the marking line
- Size difference (difference between the ordered size and the size marked on the setting ring when supplied):
For example, the ordered size is Ø10.12mm, the size marked on the setting ring when supplied may be Ø10.130mm
- Meet DIN2250-1:2008



6312-20

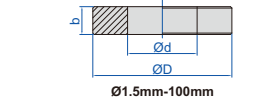

Ø1.5mm-100mm

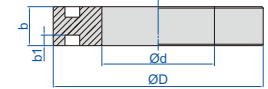

Ø100mm-400mm

Diameter d ^{***}	b	ØD	Size difference	Roundness and cylindricity
Ø1.5-2.5	4mm	22mm	±10.0µm	0.3µm
Ø2.5-3	5mm	22mm	±10.0µm	0.3µm
Ø3-5	5mm	22mm	±10.0µm	0.4µm
Ø5-10	8mm	32mm	±10.0µm	0.4µm
Ø10-15	10mm	38mm	±10.0µm	0.5µm
Ø15-18	12mm	45mm	±10.0µm	0.5µm
Ø18-20	12mm	45mm	±10.0µm	0.6µm
Ø20-25	14mm	53mm	±10.0µm	0.6µm
Ø25-30	16mm	63mm	±10.0µm	0.6µm
Ø30-32	16mm	63mm	±10.0µm	0.7µm
Ø32-40	18mm	71mm	±10.0µm	0.7µm
Ø40-50	20mm	85mm	±10.0µm	0.7µm
Ø50-60	20mm	100mm	±10.0µm	0.8µm
Ø60-70	24mm	112mm	±10.0µm	0.8µm
Ø70-80	24mm	125mm	±10.0µm	0.8µm
Ø80-90	24mm	140mm	±10.0µm	1.0µm
Ø90-100	24mm	160mm	±10.0µm	1.0µm

(mm)

Diameter d ^{***}	b	b1	ØD	Size difference	Roundness and cylindricity
Ø100-110	30mm	8mm	164mm	±10.0µm	1.0µm
Ø110-130	34mm	10mm	192mm	±10.0µm	1.0µm
Ø130-150	34mm	10mm	220mm	±10.0µm	1.2µm
Ø150-170	36mm	10mm	248mm	±10.0µm	1.5µm
Ø170-190	36mm	10mm	276mm	±10.0µm	1.5µm
Ø190-210	38mm	10mm	300mm	±10.0µm	1.5µm
Ø210-230	38mm	10mm	324mm	±10.0µm	2.5µm
Ø230-250	40mm	12mm	350mm	±10.0µm	2.5µm
Ø250-270	40mm	12mm	375mm	±10.0µm	3.0µm
Ø270-290	42mm	12mm	400mm	±10.0µm	3.0µm
Ø290-300	42mm	12mm	425mm	±10.0µm	3.0µm
Ø300-320	42mm	12mm	430mm	±10.0µm	4.0µm
Ø320-330	42mm	12mm	440mm	±10.0µm	4.0µm
Ø330-340	42mm	12mm	450mm	±10.0µm	4.0µm
Ø340-350	42mm	12mm	460mm	±10.0µm	4.0µm
Ø350-360	42mm	12mm	470mm	±10.0µm	4.0µm
Ø360-370	42mm	12mm	480mm	±10.0µm	4.0µm
Ø370-380	42mm	12mm	490mm	±10.0µm	4.0µm
Ø380-390	42mm	12mm	500mm	±10.0µm	4.0µm
Ø390-400	42mm	12mm	510mm	±10.0µm	4.0µm

(mm)

*** For example Ø3-5mm means Ø3mm< diameter d ≤ Ø5mm

Code	Size
6312-5*	Ø5mm
6312-6*	Ø6mm
6312-7*	Ø7mm
6312-8*	Ø8mm
6312-9*	Ø9mm
6312-10*	Ø10mm
6312-11*	Ø11mm
6312-12*	Ø12mm
6312-13*	Ø13mm
6312-14*	Ø14mm
6312-15*	Ø15mm
6312-16*	Ø16mm
6312-17*	Ø17mm
6312-18*	Ø18mm
6312-19*	Ø19mm
6312-20*	Ø20mm
6312-21*	Ø21mm
6312-22*	Ø22mm
6312-23*	Ø23mm
6312-24*	Ø24mm

Code	Size
6312-25*	Ø25mm
6312-26*	Ø26mm
6312-27*	Ø27mm
6312-28*	Ø28mm
6312-29*	Ø29mm
6312-30*	Ø30mm
6312-31*	Ø31mm
6312-32*	Ø32mm
6312-33*	Ø33mm
6312-34*	Ø34mm
6312-35*	Ø35mm
6312-36*	Ø36mm
6312-37*	Ø37mm
6312-38*	Ø38mm
6312-39*	Ø39mm
6312-40*	Ø40mm
6312-41*	Ø41mm
6312-42*	Ø42mm
6312-43*	Ø43mm
6312-44*	Ø44mm

Code	Size
6312-45*	Ø45mm
6312-46*	Ø46mm
6312-47*	Ø47mm
6312-48*	Ø48mm
6312-49*	Ø49mm
6312-50*	Ø50mm
6312-55*	Ø55mm
6312-60*	Ø60mm
6312-62*	Ø62mm
6312-65*	Ø65mm
6312-70*	Ø70mm
6312-75*	Ø75mm
6312-80*	Ø80mm
6312-85*	Ø85mm
6312-87*	Ø87mm
6312-90*	Ø90mm
6312-95*	Ø95mm
6312-100*	Ø100mm

*Supplied with manufacturer inspection certificate

CERAMIC MEASURING BALLS



4190-40D000

- Zirconia material, high strength and hardness, extremely wear resistance and corrosion resistance, good insulation, antistatic and magnetic resistance
- Mirror surface without holes
- Supplied with manufacturer inspection certificate

Individual

Code	Diameter	Accuracy	Roundness
4190-1D000	1.000mm	±2µm	0.5µm
4190-1D200	1.200mm	±2µm	0.5µm
4190-1D300	1.300mm	±2µm	0.5µm
4190-1D340	1.340mm	±2µm	0.5µm
4190-1D500	1.500mm	±2µm	0.5µm
4190-1D588	1.588mm (1/16")	±2µm	0.5µm
4190-1D750	1.750mm	±2µm	0.5µm
4190-2D000	2.000mm	±2µm	0.5µm
4190-2D381	2.381mm (3/32")	±2µm	0.5µm
4190-2D500	2.500mm	±2µm	0.5µm
4190-2D778	2.778mm (7/64")	±2µm	0.5µm
4190-3D000	3.000mm	±2µm	0.5µm
4190-3D175	3.175mm (1/8")	±2µm	0.5µm
4190-3D500	3.500mm	±2µm	0.5µm
4190-3D969	3.969mm (5/32")	±2µm	0.5µm
4190-4D000	4.000mm	±2µm	0.5µm
4190-4D500	4.500mm	±2µm	0.5µm
4190-4D763	4.763mm (3/16")	±2µm	0.5µm
4190-5D000	5.000mm	±2µm	0.5µm
4190-5D556	5.556mm (7/32")	±2µm	0.5µm
4190-5D953	5.953mm (15/64")	±2µm	0.5µm
4190-6D000	6.000mm	±2µm	0.5µm
4190-6D350	6.350mm (1/4")	±2µm	0.5µm
4190-6D500	6.500mm	±2µm	0.5µm
4190-6D747	6.747mm (17/64")	±2µm	0.5µm
4190-7D000	7.000mm	±2µm	0.5µm
4190-7D144	7.144mm (9/32")	±2µm	0.5µm
4190-7D500	7.500mm	±2µm	0.5µm
4190-7D938	7.938mm (5/16")	±2µm	0.5µm
4190-8D000	8.000mm	±2µm	0.5µm
4190-8D731	8.731mm (11/32")	±2µm	0.5µm

Individual

Code	Diameter	Accuracy	Roundness
4190-9D525	9.525mm (3/8")	±2µm	0.5µm
4190-10D000	10.000mm	±2µm	0.5µm
4190-10D318	10.318mm (13/32")	±2µm	0.5µm
4190-11D000	11.000mm	±2µm	0.5µm
4190-11D113	11.113mm (7/16")	±2µm	0.5µm
4190-11D509	11.509mm (29/64")	±2µm	0.5µm
4190-11D906	11.906mm (15/32")	±2µm	0.5µm
4190-12D000	12.000mm	±2µm	0.5µm
4190-12D303	12.303mm (31/64")	±2µm	0.5µm
4190-12D700	12.700mm (1/2")	±2µm	0.5µm
4190-13D000	13.000mm	±2µm	0.6µm
4190-13D494	13.494mm (17/32")	±2µm	0.6µm
4190-14D000	14.000mm	±2µm	0.6µm
4190-14D288	14.288mm (9/16")	±2µm	0.6µm
4190-15D000	15.000mm	±2µm	0.6µm
4190-15D081	15.081mm (19/32")	±2.5µm	0.6µm
4190-15D875	15.875mm (5/8")	±2.5µm	0.6µm
4190-16D000	16.000mm	±2.5µm	0.6µm
4190-16D669	16.669mm (21/32")	±2.5µm	0.6µm
4190-17D462	17.462mm (11/16")	±2.5µm	0.6µm
4190-18D000	18.000mm	±2.5µm	0.6µm
4190-18D256	18.256mm (23/32")	±2.5µm	0.6µm
4190-19D050	19.050mm (3/4")	±2.5µm	0.6µm
4190-19D844	19.844mm (25/32")	±2.5µm	0.6µm
4190-20D000	20.000mm	±2.5µm	0.6µm
4190-20D000	22.000mm	±2.5µm	1µm
4190-22D225	22.225mm (7/8")	±2.5µm	1µm
4190-23D812	23.812mm (15/16")	±2.5µm	1µm
4190-25D000	25.000mm	±2.5µm	1µm
4190-40D000	40.000mm	±2.5µm	1.5µm

Set (25 pairs)

Code	Ceramic balls included (one pair per size)
4190-S25	1, 1.5, 2, 2.5, 3, 3.5, 4, 4.5, 5, 6, 6.5, 7, 7.5, 8, 10, 11, 12, 13, 14, 15, 16, 18, 20, 22, 25mm

PLAIN PLUG GAGES

CUSTOM-MADE
 OTHER CLASSES ARE AVAILABLE, SUCH AS H8, H9
 OTHER DIAMETERS ARE AVAILABLE, SUCH AS 19.003mm
 OTHER LENGTHS ARE AVAILABLE, SUCH AS 70mm

- Supplied with Go and No-Go gages together
- Class H7
- Hardness HRC 60±2
- Standard DIN7150-2



4124-12

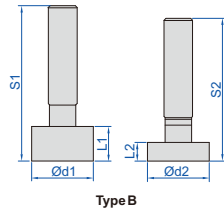
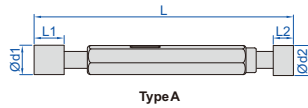
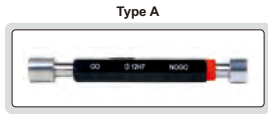

Size tolerance of H7

Diameter Ød	Type	Size tolerance of Go gage (µm)	Size tolerance of No-Go gage (µm)	L1	L2	L	S1, S2
≥2, ≤3	A	+0.5 / +2.5	+9 / +11	6.5	4.5	62	–
>3, ≤6	A	+0.75 / +3.25	+10.75 / +13.25	8	6	74	–
>6, ≤10	A	+0.75 / +3.25	+13.75 / +16.25	10	7	87	–
>10, ≤14	A	+1 / +4	+16.5 / +19.5	12	8	99	–
>14, ≤18	A	+1 / +4	+16.5 / +19.5	14	10	114	–
>18, ≤24	A	+1 / +5	+19 / +23	16	12	132	–
>24, ≤30	A	+1 / +5	+19 / +23	18	14	136	–
>30, ≤40	A	+1.5 / +5.5	+23 / +27	20	15	155	–
>40, ≤50	A	+1.5 / +5.5	+23 / +27	25	18	169	–
>50, ≤65	B	+1.5 / +6.5	+27.5 / +32.5	30	18	–	164, 152
>65, ≤80	B	+1.5 / +6.5	+27.5 / +32.5	35	25	–	169, 159
>80, ≤100	B	+2 / +8	+32 / +38	35	25	–	169, 159

Code	Diameter	Type
4124-2	2mm	A
4124-3	3mm	A
4124-4	4mm	A
4124-5	5mm	A
4124-6	6mm	A
4124-7	7mm	A
4124-8	8mm	A
4124-9	9mm	A
4124-10	10mm	A
4124-11	11mm	A
4124-12	12mm	A
4124-13	13mm	A
4124-14	14mm	A
4124-15	15mm	A
4124-16	16mm	A

Code	Diameter	Type
4124-17	17mm	A
4124-18	18mm	A
4124-19	19mm	A
4124-20	20mm	A
4124-21	21mm	A
4124-22	22mm	A
4124-23	23mm	A
4124-24	24mm	A
4124-25	25mm	A
4124-26	26mm	A
4124-27	27mm	A
4124-28	28mm	A
4124-29	29mm	A
4124-30	30mm	A
4124-31	31mm	A

Code	Diameter	Type
4124-32	32mm	A
4124-33	33mm	A
4124-34	34mm	A
4124-35	35mm	A
4124-36	36mm	A
4124-37	37mm	A
4124-38	38mm	A
4124-39	39mm	A
4124-40	40mm	A
4124-41	41mm	A
4124-42	42mm	A
4124-43	43mm	A
4124-44	44mm	A
4124-45	45mm	A
4124-46	46mm	A

Code	Diameter	Type
4124-47	47mm	A
4124-48	48mm	A
4124-49	49mm	A
4124-50	50mm	A
4124-52	52mm	B
4124-55	55mm	B
4124-60	60mm	B
4124-65	65mm	B
4124-70	70mm	B
4124-75	75mm	B
4124-80	80mm	B
4124-85	85mm	B
4124-90	90mm	B
4124-95	95mm	B
4124-100	100mm	B

THREADED HOLE LOCATION GAGES

INSIZE PLUS
 MADE IN EUROPE

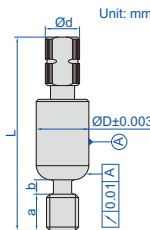

4676-12

ATTENTION: ONLY FOR THE WORKPIECES THAT THE CHAMFER IS CONCENTRIC WITH THE SCREW PART

- Only for the workpieces that the chamfer is concentric with the screw part

Code	Size (mm)	Ød	ØD	a	b	L
4676-3	M3×0.5	4mm	7mm	4mm	2mm	26mm
4676-4	M4×0.7	4mm	7mm	4mm	2mm	26mm
4676-5	M5×0.8	5.5mm	9mm	6mm	2mm	33mm
4676-6	M6×1.0	5.5mm	9mm	6mm	2mm	33mm
4676-8	M8×1.25	8.5mm	13mm	9mm	3.5mm	48mm
4676-10	M10×1.5	8.5mm	13mm	9mm	3.5mm	48mm
4676-12	M12×1.75	12mm	17mm	10mm	3.5mm	55mm

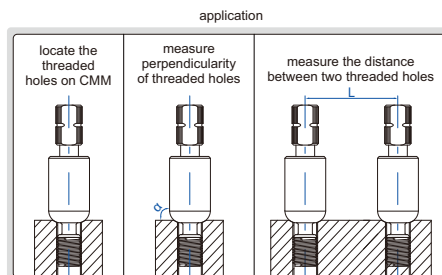

there is a R-shaped guide, which leads the gage to the center of the threaded holes by fitting the R-shaped guide on the chamfer of the threaded holes

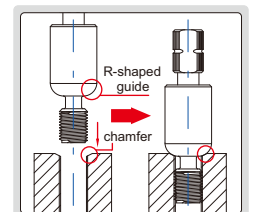

METRIC THREAD RING GAGES



WARNING: LIFE TIME IS LIMITED,
CAN BE USED ABOUT 2000 TIMES

- Standard ISO1502
- Supplied with manufacturer inspection certificate



4120-16



4120-16N

Individual

Size (mm)		Code					
Nominal diameter	Pitch	Class 6g		Class 6e		Class 6h	
		GO	NOGO	GO	NOGO	GO	NOGO
M2	0.4	4120-2	4120-2N	4120-2E	4120-2EN	4120-2H	4120-2HN
M2.2	0.45	4120-2D2	4120-2D2N	4120-2D2E	4120-2D2EN	4120-2D2H	4120-2D2HN
M2.3	0.4	4120-2D3	4120-2D3N	–	–	–	–
M2.5	0.45	4120-2D5	4120-2D5N	4120-2D5E	4120-2D5EN	4120-2D5H	4120-2D5HN
M2.6	0.45	4120-2D6	4120-2D6N	–	–	–	–
M3	0.5	4120-3	4120-3N	4120-3E	4120-3EN	4120-3H	4120-3HN
M3.5	0.6	4120-3D5	4120-3D5N	4120-3D5E	4120-3D5EN	4120-3D5H	4120-3D5HN
M4	0.7	4120-4	4120-4N	4120-4E	4120-4EN	4120-4H	4120-4HN
M4.5	0.75	4120-4D5	4120-4D5N	4120-4D5E	4120-4D5EN	4120-4D5H	4120-4D5HN
M5	0.8	4120-5	4120-5N	4120-5E	4120-5EN	4120-5H	4120-5HN
M6	1	4120-6	4120-6N	4120-6E	4120-6EN	4120-6H	4120-6HN
M7	1	4120-7	4120-7N	4120-7E	4120-7EN	4120-7H	4120-7HN
M8	1.25	4120-8	4120-8N	4120-8E	4120-8EN	4120-8H	4120-8HN
M9	1.25	4120-9	4120-9N	4120-9E	4120-9EN	4120-9H	4120-9HN
M10	1.5	4120-10	4120-10N	4120-10E	4120-10EN	4120-10H	4120-10HN
M11	1.5	4120-11	4120-11N	4120-11E	4120-11EN	4120-11H	4120-11HN
M12	1.75	4120-12	4120-12N	4120-12E	4120-12EN	4120-12H	4120-12HN
M14	2	4120-14	4120-14N	4120-14E	4120-14EN	4120-14H	4120-14HN
M16	2	4120-16	4120-16N	4120-16E	4120-16EN	4120-16H	4120-16HN
M18	2.5	4120-18	4120-18N	4120-18E	4120-18EN	4120-18H	4120-18HN
M20	2.5	4120-20	4120-20N	4120-20E	4120-20EN	4120-20H	4120-20HN
M22	2.5	4120-22	4120-22N	4120-22E	4120-22EN	4120-22H	4120-22HN
M24	3	4120-24	4120-24N	4120-24E	4120-24EN	4120-24H	4120-24HN
M27	3	4120-27	4120-27N	4120-27E	4120-27EN	4120-27H	4120-27HN
M30	3.5	4120-30	4120-30N	4120-30E	4120-30EN	4120-30H	4120-30HN
M33	3.5	4120-33	4120-33N	4120-33E	4120-33EN	4120-33H	4120-33HN
M36	4	4120-36	4120-36N	4120-36E	4120-36EN	4120-36H	4120-36HN
M39	4	4120-39	4120-39N	4120-39E	4120-39EN	4120-39H	4120-39HN
M42	4.5	4120-42	4120-42N	–	–	4120-42H	4120-42HN
M45	4.5	4120-45	4120-45N	–	–	4120-45H	4120-45HN
M48	5	4120-48	4120-48N	–	–	4120-48H	4120-48HN
M52	5	4120-52	4120-52N	–	–	4120-52H	4120-52HN
M56	5.5	4120-56	4120-56N	–	–	–	–
M60	5.5	4120-60	4120-60N	–	–	–	–

Go ring gage set (Class 6g)

Code	Thread plug gages included (mm)
4120-S7	M3x0.5 (4120-3), M4x0.7 (4120-4), M5x0.8 (4120-5), M6x1 (4120-6), M8x1.25 (4120-8), M10x1.5 (4120-10), M12x1.75 (4120-12)

NO Go ring gage set (Class 6g)

Code	Thread plug gages included (mm)
4120-S7N	M3x0.5 (4120-3N), M4x0.7 (4120-4N), M5x0.8 (4120-5N), M6x1 (4120-6N), M8x1.25 (4120-8N), M10x1.5 (4120-10N), M12x1.75 (4120-12N)

METRIC THREAD PLUG GAGES



4130-10

- Supplied with Go and No-Go gages together
- Standard ISO1502
- Supplied with manufacturer inspection certificate

Individual

Size (mm)		Code		
Nominal diameter	Pitch	Class 6H	Class 6G	Class 4H
M0.8	0.2	4130-D8	4130-D8G	–
M0.9	0.225	4130-D9	–	–
M1	0.25	4130-1	–	4130-1H
M1.2	0.25	4130-1D2	4130-1D2G	4130-1D2H
M1.4	0.3	4130-1D4	–	4130-1D4H
M1.6	0.35	4130-1D6	4130-1D6G	4130-1D6H
M1.7	0.35	4130-1D7	–	–
M1.8	0.35	4130-1D8	4130-1D8G	4130-1D8H
M2	0.4	4130-2	4130-2G	4130-2H
M2.2	0.45	4130-2D2	4130-2D2G	4130-2D2H
M2.3	0.4	4130-2D3	4130-2D3G	–
M2.5	0.45	4130-2D5	4130-2D5G	4130-2D5H
M2.6	0.45	4130-2D6	4130-2D6G	–
M3	0.5	4130-3	4130-3G	4130-3H
M3.5	0.6	4130-3D5	4130-3D5G	4130-3D5H
M4	0.7	4130-4	4130-4G	4130-4H
M4.5	0.75	4130-4D5	4130-4D5G	4130-4D5H
M5	0.8	4130-5	4130-5G	4130-5H
M6	1	4130-6	4130-6G	4130-6H
M7	1	4130-7	4130-7G	4130-7H
M8	1.25	4130-8	4130-8G	4130-8H
M9	1.25	4130-9	4130-9G	4130-9H
M10	1.5	4130-10	4130-10G	4130-10H
M11	1.5	4130-11	4130-11G	4130-11H
M12	1.75	4130-12	4130-12G	4130-12H
M14	2	4130-14	4130-14G	4130-14H
M16	2	4130-16	4130-16G	4130-16H
M18	2.5	4130-18	4130-18G	4130-18H
M20	2.5	4130-20	4130-20G	4130-20H
M22	2.5	4130-22	4130-22G	–
M24	3	4130-24	4130-24G	–
M27	3	4130-27	4130-27G	–
M30	3.5	4130-30	4130-30G	–
M33	3.5	4130-33	4130-33G	–
M36	4	4130-36	4130-36G	4130-36H
M39	4	4130-39	4130-39G	–
M42	4.5	4130-42	–	–
M45	4.5	4130-45	–	–
M48	5	4130-48	–	–
M52	5	4130-52	4130-52G	–
M56	5.5	4130-56	–	–
M60	5.5	4130-60	–	–

Set (class 6H)

Code	Thread plug gages included (mm)
4130-S7	M3x0.5 (4130-3), M4x0.7 (4130-4), M5x0.8 (4130-5), M6x1 (4130-6), M8x1.25 (4130-8), M10x1.5 (4130-10), M12x1.75 (4130-12)

ANGLE, STRAIGHTNESS, FLATNESS MEASUREMENT

14



Protractors
Page 108-110



Granite Squares
Page 110



Perpendicularity Testers
Page 110



Squares
Page 111-113



Straight Edges
Page 113



Straight Edges
Page 113-114



Optical Flats
Page 114

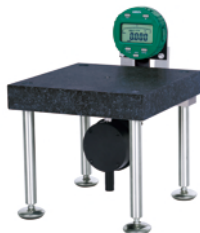

Flatness Measurement Stands
Page 114

WATERPROOF DIGITAL PROTRACTOR (HEAVY DUTY)

**AUTOMATIC
BACKLIGHT**

**ABSOLUTE
LEVEL**

**IP54
WATERPROOF**

- Suitable for setting horizontal and vertical mitre angles of cutting machine
- Buttons: ON/OFF, HOLD/SUP, SPR/CNR/MTR/BVL
- IP54 dust/waterproof
- With transverse and longitudinal vials
- 2xAAA batteries
- Absolute level, zero setting is not needed when batteries are replaced
- Backlight turns off in one minute after no data changing, automatic power off in 5 minutes



2174-225

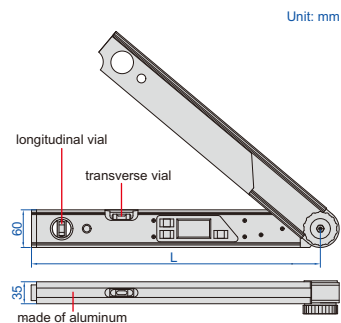

Unit: mm

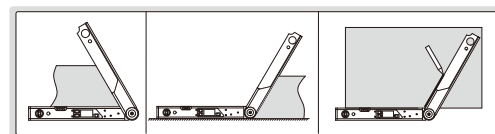

Code	Size (L)	Range	Resolution	Accuracy
2174-225	460mm	0-225°	0.05°	±0.10°

DIGITAL PROTRACTOR

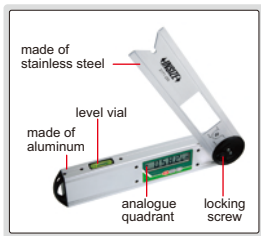
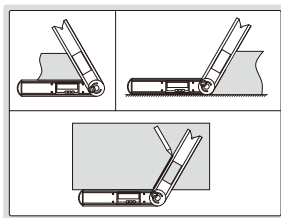

2171-250

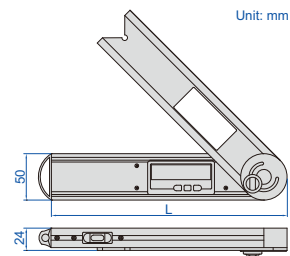

Unit: mm

- Buttons: on/off, hold (keep the reading), zero, ABS (absolute and incremental measurement)
- Fix the locking screw at 4 positions for different measuring ranges: 0°~225°, -225°~0°, -45°~180°, -180°~45°
- Remove the locking screw for 360° range
- With level vial
- Battery CR2032
- Automatic power off

Code	Size (L)	Range	Resolution	Accuracy
2171-250	250mm	0-360°	0.05°	±0.15°

DIGITAL PROTRACTORS

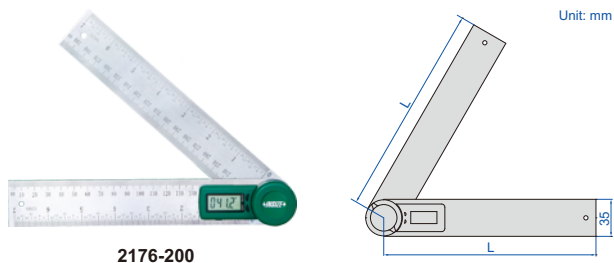

2176-200

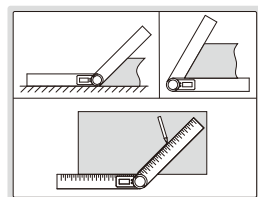

Unit: mm

- Resolution: 0.1°
- Buttons: on/off, zero
- With clamping screw to lock the blades
- Graduation of blade: 1mm and 1/32"
- Made of stainless steel
- CR2032 battery, automatic power off

Code	Size (L)	Range	Accuracy
2176-200	200mm	0-360°	±0.3°
2176-300	300mm	0-360°	±0.3°

PROTRACTOR (ECONOMIC TYPE)



4780-85A

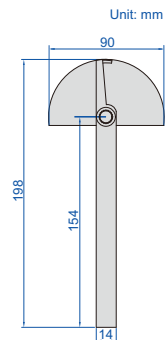

Unit: mm

- Graduation: 1°
- Made of stainless steel
- With clamping screw

Code	Size	Range	Accuracy
4780-85A	90x154mm	0-180°	±0.5°

PROTRACTOR



4781-85A

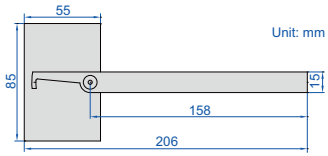

Unit: mm

- Graduation: 1°
- Accuracy: $\pm 0.3^\circ$
- Made of stainless steel
- Satin chrome plated scale
- With clamping screw

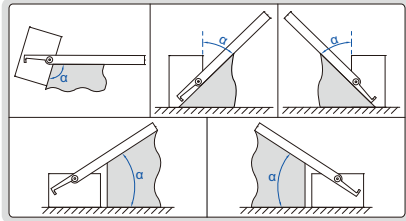

Code	Size	Range
4781-85A	85x158mm	0-180°

PROTRACTORS



4797-100

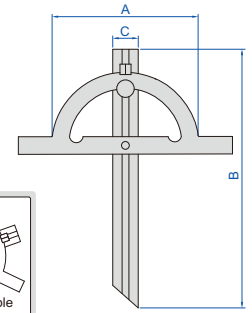

- Graduation: 1°
- Made of carbon steel
- Satin chrome plated
- With clamping screw
- The blade is moveable

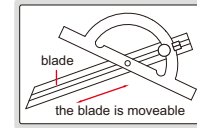

Code	Size (AxB)	Range	Accuracy	C
4797-100	100x150mm	10-170°	$\pm 0.3^\circ$	18mm
4797-150	150x300mm	10-170°	$\pm 0.3^\circ$	22mm
4797-200	200x400mm	10-170°	$\pm 0.3^\circ$	24mm
4797-250	250x500mm	10-170°	$\pm 0.3^\circ$	28mm
4797-300	300x600mm	10-170°	$\pm 0.3^\circ$	32mm

PROTRACTORS



4799-180

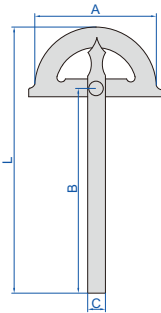

- Graduation: 1°
- Made of stainless steel (4799-1300 is made of carbon steel)
- Satin chrome plated scale
- With clamping screw

Code	Size (AxB)	Range	Accuracy	L	C
4799-180	80x120mm	0-180°	$\pm 0.3^\circ$	168mm	11mm
4799-1120	120x150mm	0-180°	$\pm 0.3^\circ$	220mm	14mm
4799-1150	150x200mm	0-180°	$\pm 0.3^\circ$	285mm	16mm
4799-1200	200x300mm	0-180°	$\pm 0.3^\circ$	413mm	20mm
4799-1300	300x500mm	0-180°	$\pm 0.3^\circ$	675mm	30mm

PROTRACTOR

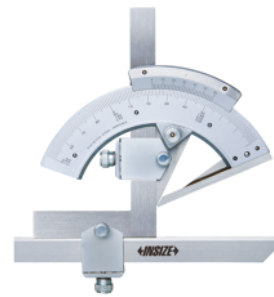

2374-320

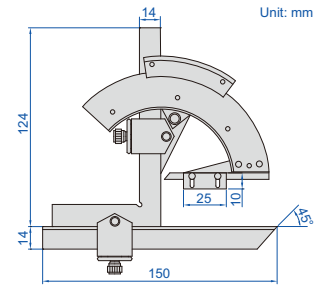

Unit: mm

- Graduation: 2'
- Made of stainless steel
- Satin chrome plated scale

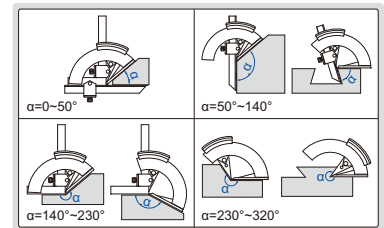

Code	Range	Accuracy
2374-320	0-320°	$\pm 2'$

UNIVERSAL PROTRACTOR

clamp for height gages (optional)

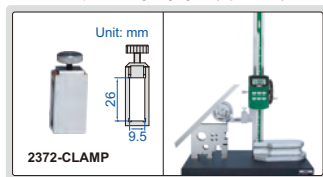

- Graduation: 5'
- Parallax-free reading
- Made of stainless steel
- Optional accessory: clamp (code 2372-CLAMP), suitable for height gages 1156, 1150-300, 1351, 1151 and 1250

Code	Range	Accuracy
2372-360	0-360°	$\pm 5'$

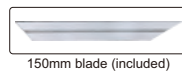

150mm blade (included)

300mm blade (included)

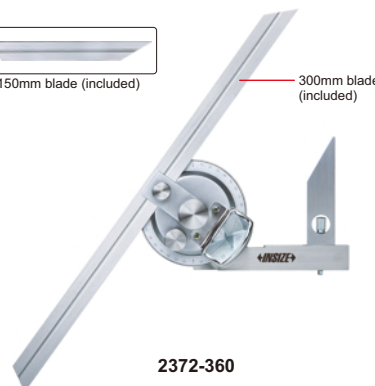

2372-360

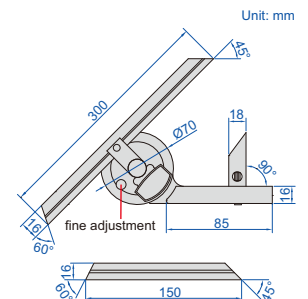

Unit: mm

DIGITAL PROTRACTOR

ABSOLUTE ZERO

DATA OUTPUT

POPULAR MODEL

clamp for height gages (optional)

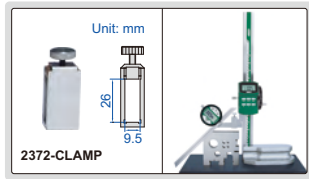

150mm blade (included)

300mm blade (included)



2771-360

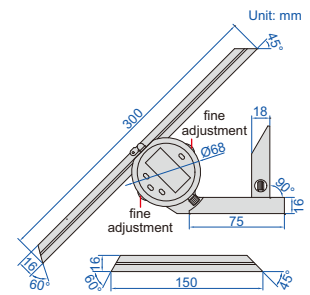

- Absolute zero, zero setting is not needed when batteries are replaced
- Button function: choose 0~90°, 0-180° or 0-360° display, change resolution, display flips over, data hold, zero, on/off supplementary angle measurement
- Battery CR2032, automatic power off
- Data output
- Made of stainless steel
- Optional square for zero setting
- Optional accessory: clamp (code 2372-CLAMP), suitable for height gages 1156, 1150-300, 1351, 1250 and 1151, data output cable (code 7315-2771 receiver is needed, 7302-50M)

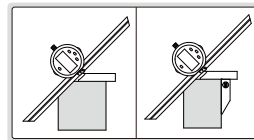

square (optional)

Square (for zero setting, optional)

Code
2771-S90



Code	Range	Resolution	Accuracy
2771-360	0-360°	1/0.01°	±5'

GRANITE SQUARES

CUSTOM-MADE
SUPPLY SPECIAL SIZES ACCORDING
TO CUSTOMER'S REQUEST



4141-250

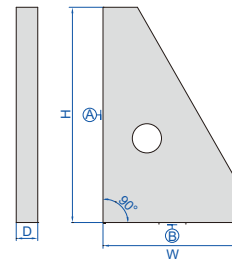

Code	Size (HxW)	Flatness of A	Flatness of B	Squareness of A to B	D
4141-250	250x160mm	1µm	1µm	2µm	25mm
4141-400	400x250mm	1.5µm	1µm	3µm	40mm

PERPENDICULARITY TESTERS



VIDEO

- Optional accessory: dial test indicators (graduation: 1µm or 2µm)



dial test indicator is optional



4770-300

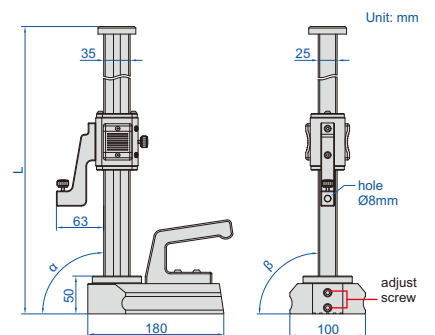

Code	Range (H)	Perpendicularity (α)	Side perpendicularity (β)	L
4770-300	0-300mm	3µm	10µm	460mm
4770-600	0-600mm	5µm	20µm	760mm

90° BEVELED EDGE SQUARES



4790-0100

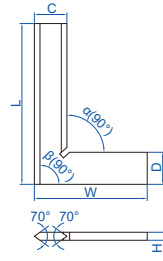

- Satin chrome plating
- Beveled edges for inside and outside measurement
- Made of hardened stainless steel

DIN875 grade 00

(mm)

Code	Size (LxW)	Squareness		C	D	H
		Inside (α)	Outside (β)			
4790-0100	100x70mm	2.8μm	3.0μm	20	20	5
4790-0150	150x100mm	3.2μm	3.5μm	30	30	6

DIN875 grade 0

(mm)

Code	Size (LxW)	Squareness		C	D	H
		Inside (α)	Outside (β)			
4790-500	50x40mm	6μm	6μm	13	13	4
4790-750	75x50mm	6μm	7μm	15	15	4
4790-1000	100x70mm	7μm	7μm	20	20	5
4790-1500	150x100mm	7μm	8μm	30	30	6
4790-2000	200x130mm	8μm	9μm	34	34	7

90° FLAT EDGE SQUARES



4791-100

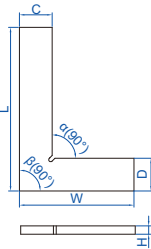

- Made of hardened stainless steel

DIN875 grade 1

(mm)

Code	Size (LxW)	Squareness		C	D	H
		Inside (α)	Outside (β)			
4791-501	50x40mm	12μm	13μm	15	15	4
4791-751	75x50mm	13μm	14μm	15	15	4
4791-1001	100x70mm	14μm	15μm	20	20	5
4791-1501	150x100mm	16μm	18μm	30	30	6
4791-2001	200x130mm	19μm	20μm	30	30	7
4791-2501	250x165mm	21μm	23μm	35	35	7
4791-3001	300x200mm	23μm	25μm	40	40	8

DIN875 grade 0

(mm)

Code	Size (LxW)	Squareness		C	D	H
		Inside (α)	Outside (β)			
4791-50	50x40mm	6μm	6μm	15	15	4
4791-75	75x50mm	6μm	7μm	15	15	4
4791-100	100x70mm	7μm	7μm	20	20	5
4791-150	150x100mm	7μm	8μm	30	30	6
4791-200	200x130mm	8μm	9μm	30	30	7
4791-250	250x165mm	9μm	10μm	35	35	7
4791-300	300x200mm	10μm	11μm	40	40	8

DIN875 grade 2

(mm)

Code	Size (LxW)	Squareness		C	D	H
		Inside (α)	Outside (β)			
4791-502	50x40mm	24μm	25μm	15	15	4
4791-752	75x50mm	26μm	28μm	15	15	4
4791-1002	100x70mm	28μm	30μm	20	20	5
4791-1502	150x100mm	33μm	35μm	30	30	6
4791-2002	200x130mm	38μm	40μm	30	30	7
4791-2502	250x165mm	43μm	45μm	35	35	7
4791-3002	300x200mm	47μm	50μm	40	40	8

MACHINIST SQUARES WITH WIDE BASE (ECONOMIC TYPE)

ATTENTION: NO ANTI-RUST TREATMENT, NOT HARDEND



4707-100

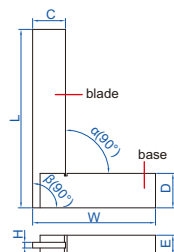

- DIN875 grade 2
- Made of carbon steel, no anti-rust treatment, not hardend

(mm)

Code	Size (LxW)	Squareness		C	D	H	E
		Inside (α)	Outside (β)				
4707-50	50x40mm	24μm	25μm	16	12	3	9
4707-100	100x70mm	28μm	30μm	19	19	3	12
4707-150	150x100mm	33μm	35μm	25	25	3	16
4707-250	250x165mm	42μm	45μm	30	32	4	19
4707-300	300x200mm	47μm	50μm	32	32	4	19
4707-400	400x250mm	56μm	60μm	38	38	5	22

90° FLAT EDGE SQUARES WITH WIDE BASE

- Made of hardened stainless steel



4793-100

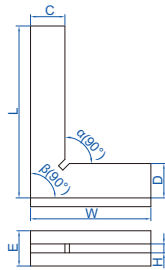

DIN875 grade 1

(mm)

Code	Size (LxW)	Squareness		C	D	H	E
		Inside (α)	Outside (β)				
4793-501	50x40mm	12μm	13μm	15	15	4	13
4793-751	75x50mm	13μm	14μm	15	15	4	15
4793-1001	100x70mm	14μm	15μm	20	20	5	20
4793-1501	150x100mm	16μm	18μm	30	30	6	30
4793-2001	200x130mm	19μm	20μm	30	30	7	30
4793-2501	250x165mm	21μm	23μm	35	35	7	35
4793-3001	300x200mm	23μm	25μm	40	40	8	40

DIN875 grade 0

(mm)

Code	Size (LxW)	Squareness		C	D	H	E
		Inside (α)	Outside (β)				
4793-50	50x40mm	6μm	6μm	15	15	4	13
4793-75	75x50mm	6μm	7μm	15	15	4	15
4793-100	100x70mm	7μm	7μm	20	20	5	20
4793-150	150x100mm	7μm	8μm	30	30	6	30
4793-200	200x130mm	8μm	9μm	30	30	7	30
4793-250	250x165mm	9μm	10μm	35	35	7	35
4793-300	300x200mm	10μm	11μm	40	40	8	40

DIN875 grade 2

(mm)

Code	Size (LxW)	Squareness		C	D	H	E
		Inside (α)	Outside (β)				
4793-502	50x40mm	24μm	25μm	15	15	4	13
4793-752	75x50mm	26μm	28μm	15	15	4	15
4793-1002	100x70mm	28μm	30μm	20	20	5	20
4793-1502	150x100mm	33μm	35μm	30	30	6	30
4793-2002	200x130mm	38μm	40μm	30	30	7	30
4793-2502	250x165mm	43μm	45μm	35	35	7	35
4793-3002	300x200mm	47μm	50μm	40	40	8	40

MACHINIST SQUARES (ECONOMIC TYPE)

ATTENTION: NO ANTI-RUST TREATMENT, NOT HARDENED



4796-150

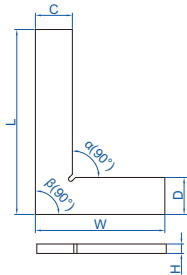

- DIN875 grade 2
- Made of carbon steel, no anti-rust treatment, not hardened

(mm)

Code	Size (LxW)	Squareness		C	D	H
		Inside (α)	Outside (β)			
4796-50	50x30mm	24μm	25μm	12	12	3
4796-75	75x50mm	26μm	28μm	16	16	3
4796-100	100x70mm	28μm	30μm	19	19	5
4796-125	125x80mm	30μm	33μm	22	22	5
4796-150	150x100mm	33μm	35μm	25	25	6
4796-200	200x130mm	38μm	40μm	25	25	6
4796-250	250x165mm	43μm	45μm	25	25	6
4796-300	300x200mm	47μm	50μm	30	30	6
4796-350	350x200mm	51μm	55μm	38	38	6
4796-400	400x200mm	56μm	60μm	38	38	9
4796-450	450x250mm	58μm	65μm	38	38	9
4796-500	500x300mm	69μm	70μm	38	38	9

TRY SQUARE

- Graduation: 1mm
- Aluminum blade and base
- 4 milled surfaces
- Retractable metal ledge support
- Etchings and holes for beveling and framing: 10°, 15°, 22.5°, 30°, 45°, 50° and 60°
- Etchings and holes every cm for fluid pencil marking

Code	Size (LxW)	Squareness	
		Inside (α)	Outside (β)
2280-300	300x150mm	0.5mm	0.5mm

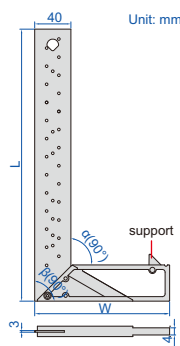

2280-300

TRY SQUARE

- Graduation: 1mm
- Stainless steel blade, aluminum base

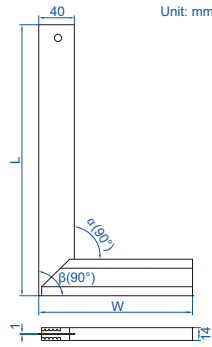

2275-300

Code	Size (LxW)	Squareness	
		Inside (α)	Outside (β)
2275-300	300x170mm	0.5mm	0.5mm

45° SQUARES

- Made of hardened stainless steel

Code	Size (LxW)	Squareness		C	D	H
		Inside (α)	Outside (β)			
4745-1120	120x80mm	29 μ m	32 μ m	20mm	20mm	5mm
4745-1150	150x100mm	32 μ m	35 μ m	20mm	20mm	5mm
4745-1200	200x130mm	36 μ m	40 μ m	25mm	25mm	5mm



4745-1120

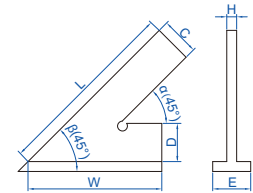

STRAIGHT EDGES



4700-100

- DIN874
- Beveled edge
- Made of hardened stainless steel
- Satin chrome plating

Code	Size (L)	Straightness	W	H
4700-50	50mm	2.2 μ m	5mm	20mm
4700-75	75mm	2.3 μ m	5mm	25mm
4700-100	100mm	2.4 μ m	5mm	25mm
4700-125	125mm	2.5 μ m	6mm	30mm
4700-150	150mm	2.6 μ m	6mm	30mm
4700-200	200mm	2.8 μ m	6mm	30mm
4700-250	250mm	3.0 μ m	8mm	40mm
4700-300	300mm	3.2 μ m	8mm	40mm
4700-400	400mm	3.6 μ m	10mm	50mm
4700-500	500mm	4.0 μ m	10mm	50mm

GRANITE STRAIGHT EDGES

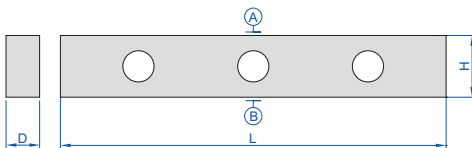

4147-500A

Code	Length (L)	Flatness of A and B	Parallelism between A and B	D	H
4147-500A	500mm	2.1 μ m	3.2 μ m	50mm	80mm
4147-1000A	1000mm	3.0 μ m	4.5 μ m	60mm	120mm

MAGNALIUM STRAIGHT EDGES

LIGHT WEIGHT

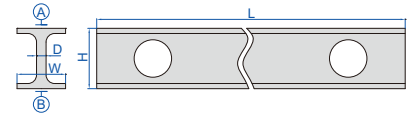

- Made of magnalium, light weight, non-deform, no rusty

4180-1500

Code	Length (L)	Flatness of A and B	Parallelism between A and B	H	W	D	Weight
4180-500	500mm	3 μ m	4 μ m	60mm	30mm	5mm	1kg
4180-1000	1000mm	5 μ m	8 μ m	60mm	30mm	5mm	1.5kg
4180-1500	1500mm	15 μ m	22 μ m	100mm	40mm	7mm	4.5kg
4180-2000	2000mm	18 μ m	27 μ m	100mm	40mm	7mm	6kg
4180-2500	2500mm	22 μ m	33 μ m	100mm	40mm	7mm	7.5kg
4180-3000	3000mm	48 μ m	72 μ m	150mm	80mm	8mm	21kg

PRECISION STRAIGHT EDGES WITH BEVELED EDGE



7118-300

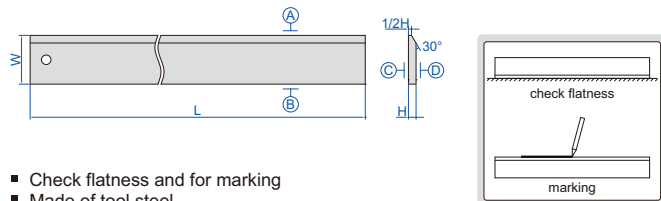

- Check flatness and for marking
- Made of tool steel

Code	Range (L)	Flatness of A and B	Flatness of C and D	W	H
7118-300	305mm	0.005mm	0.05mm	41mm	6.3mm
7118-600	610mm	0.006mm	0.06mm	51mm	7.9mm
7118-900	914mm	0.007mm	0.06mm	64mm	9.5mm

OPTICAL FLATS



4191-45B

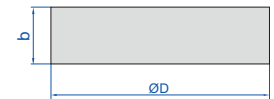

- Check flatness
- Single working face, the arrow indicates the working face

Code	b	ØD	Flatness
4191-45A	12mm	45mm	0.03 μ m
4191-60A	15mm	60mm	0.03 μ m

Code	b	ØD	Flatness
4191-45B	12mm	45mm	0.1 μ m
4191-60B	15mm	60mm	0.1 μ m

FLATNESS MEASUREMENT STAND

DATA OUTPUT

GRANITE PLATE CAN BE CUSTOMIZED ACCORDING TO WORKPIECES

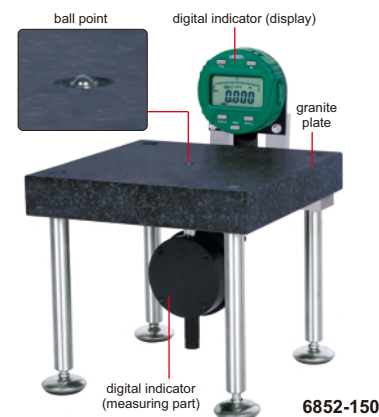

6852-150

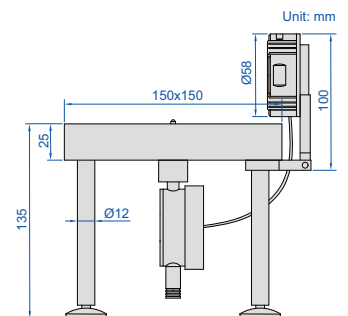

- Optional accessory: data output cable (code 7315-50M, 7302-40M, 7305-40M)

Code	Digital indicator resolution	Flatness measurement accuracy	Flatness of granite plate
6852-150	0.001mm/0.00005"	2 μ m	2 μ m



Concentricity Gages
Page 116-118



Bench Centers
Page 118-119

CONCENTRICITY GAGES

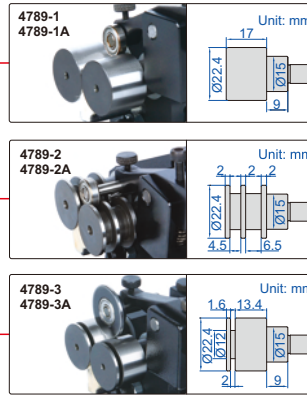
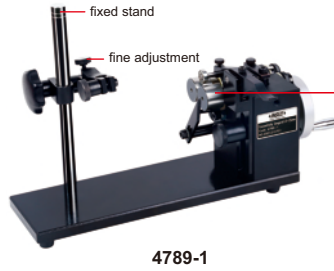
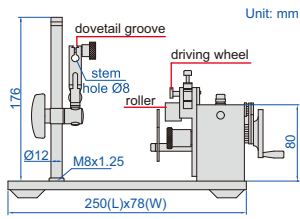

- Accuracy 2µm
- Optional accessory: dial test indicator

Code	Applicable diameter	Remark
4789-1	Ø3.5mm-25mm	fixed stand, high accuracy, inconvenient operation
4789-2	Ø1mm-25mm	fixed stand, high accuracy, inconvenient operation
4789-3	Ø1mm-25mm	fixed stand, high accuracy, inconvenient operation
4789-1A	Ø3.5mm-25mm	universal stand, low accuracy, convenient operation
4789-2A	Ø1mm-25mm	universal stand, low accuracy, convenient operation
4789-3A	Ø1mm-25mm	universal stand, low accuracy, convenient operation

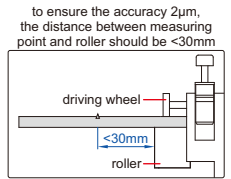

CONCENTRICITY GAGES

HIGH STABILITY,
LONG WORKING LIFE

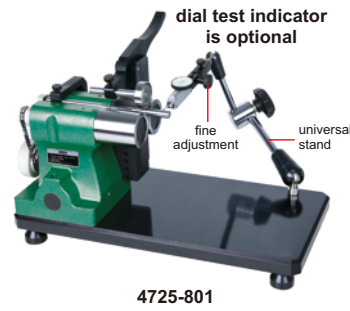
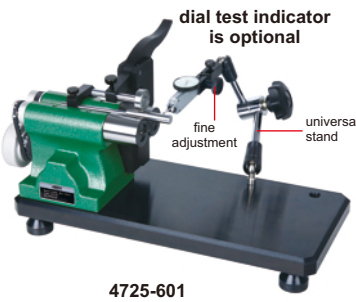
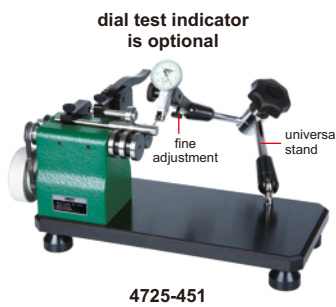
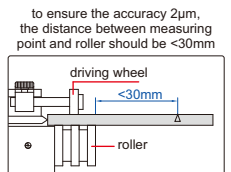
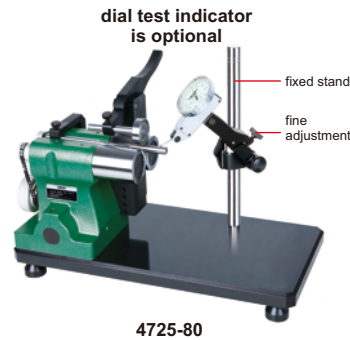
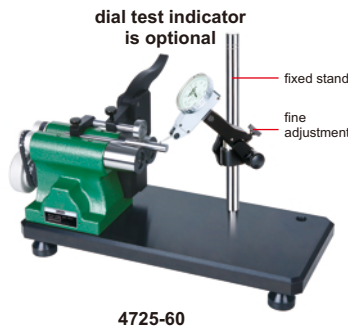

- With ball bearing, high stability, long working life
- Accuracy: 2µm
- Optional accessory: dial test indicator

Code	Diameter range	Center height (h)	LxWxH	Weight	Remark
4725-45	Ø3-45mm	80mm	280x130x170mm	6kg	fixed stand, high accuracy, inconvenient operation
4725-60	Ø8-60mm	90mm	350x160x190mm	15.6kg	
4725-80	Ø8-80mm	130mm	400x200x250mm	25kg	
4725-451	Ø3-45mm	80mm	280x130x170mm	6kg	universal stand, low accuracy, convenient operation
4725-601	Ø8-60mm	90mm	350x160x190mm	15.6kg	
4725-801	Ø8-80mm	130mm	400x200x250mm	25kg	

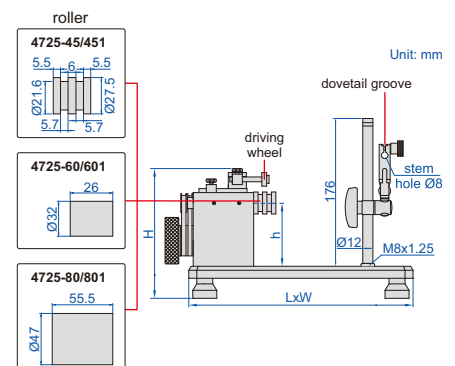

CONCENTRICITY GAGES

QUICK-POSITIONING, SUITABLE FOR MASS MEASUREMENT

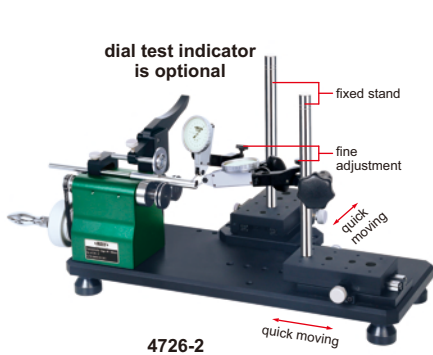

4726-2

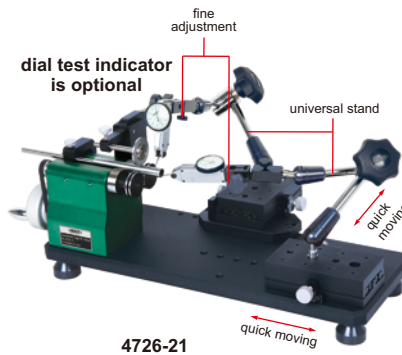

4726-21

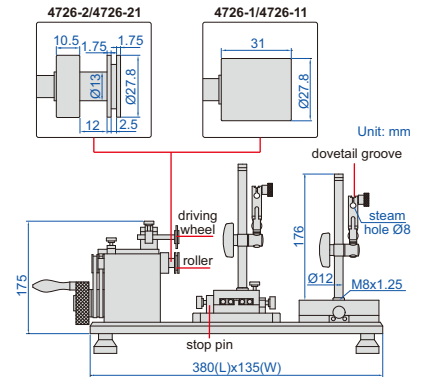

Unit: mm

- With ball bearing, high stability, long working life
- Accuracy: 2 μ m
- Optional accessory: dial test indicator

Code	Applicable diameter	Remark
4726-1	Ø4-40mm	fixed stand, high accuracy, inconvenient operation
4726-2	Ø2-40mm	fixed stand, high accuracy, inconvenient operation
4726-11	Ø4-40mm	universal stand, low accuracy, convenient operation
4726-21	Ø2-40mm	universal stand, low accuracy, convenient operation



to ensure the accuracy 2 μ m, the distance between measuring point and roller should be <30mm

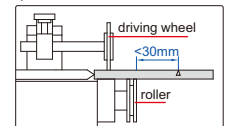

QUICK POSITIONING CONCENTRICITY GAGES

QUICK-POSITIONING, SUITABLE FOR MASS MEASUREMENT

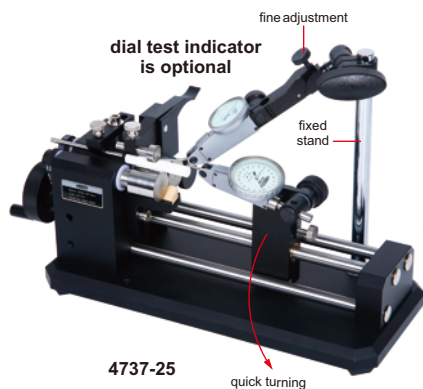

4737-25

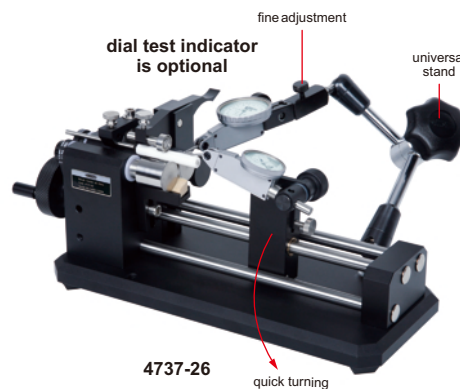

4737-26

standard rod (included)



to ensure the accuracy 2 μ m, the distance between measuring point and roller should be <30mm

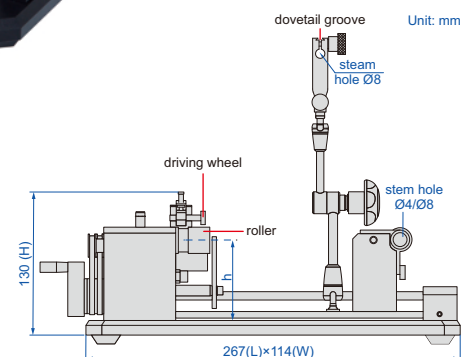
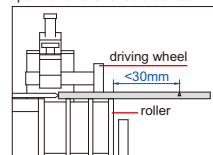

Unit: mm

- Quick positioning, suitable for mass measurement
- Supplied with standard rod to verify accuracy
- Optional accessory: dial test indicators

Code	Diameter range	Workpiece length	Accuracy	Center height (h)	L×W×H	Weight	Remark
4737-25	Ø3-25mm	15-100mm	2 μ m	70mm	267×114×130mm	3kg	fixed stand, high accuracy, inconvenient operation
4737-26	Ø3-25mm	15-100mm	2 μ m	70mm	267×114×130mm	3kg	universal stand, low accuracy, convenient operation

CONCENTRICITY GAGES

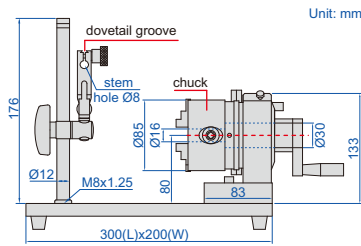

Unit: mm

- Accuracy: 3µm
- Ø50mm setting ring and Ø55mm calibration cylinder are included
- Optional accessory: dial test indicator

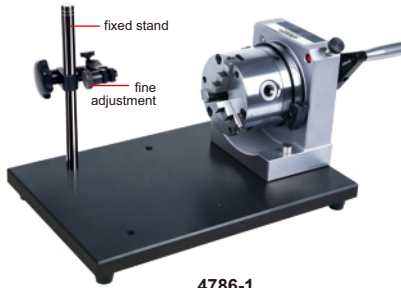

4786-1

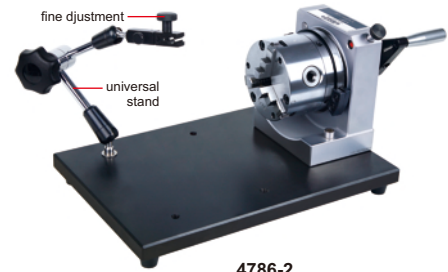

4786-2



for cylinder

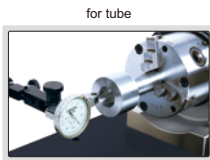

for tube

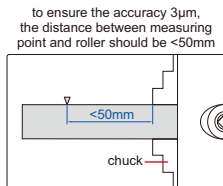

to ensure the accuracy 3µm, the distance between measuring point and roller should be <50mm

Code	Applicable inside diameter	Applicable outside diameter	Remark
4786-1	Ø24-64mm	Ø2-70mm	fixed stand, high accuracy, inconvenient operation
4786-2	Ø24-64mm	Ø2-70mm	universal stand, low accuracy, convenient operation

MINI BENCH CENTER

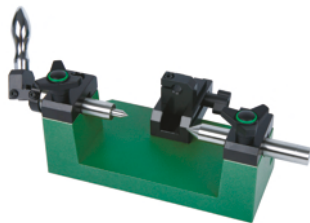

4721-75A

- Distance between two centers (D): 35-100mm
- Diameter of center (Ød): 6mm
- Taper of center: MT1

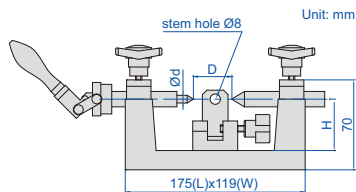

Unit: mm

Code	Runout accuracy	Center height (H)	Weight	Load
4721-75A	2µm	40mm	4.5kg	4kg

BENCH CENTER (BASIC TYPE)

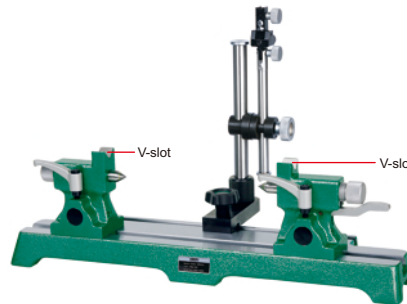

4782-300

- Distance between two centers: 300mm
- Hardened cast-iron guide surface
- Movable column
- V-slot for cylinder Ø4~Ø22mm

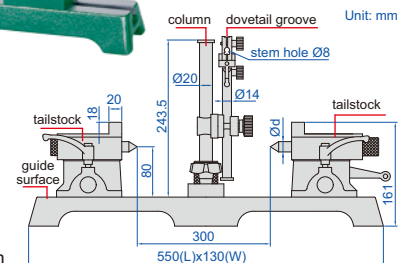

Unit: mm

Code	Parallelism*	Runout accuracy	Center height	Diameter of center (Ød)	Load
4782-300	0.01mm	2µm	80mm	Ø16mm	25kg

*Parallelism of two centers to the guide surface

BENCH CENTERS

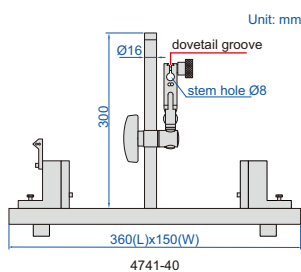

4741-40

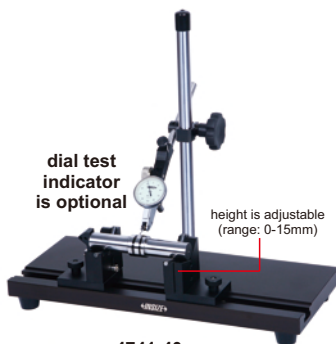

4741-40

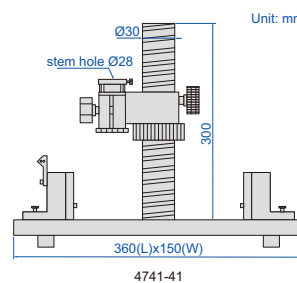

4741-41

high precision digital indicator is optional



4741-41

- Quick positioning, suitable for mass measurement
- 4741-40 optional accessory: dial test indicators (code 2880-02, 2880-02R)
- 4741-41 optional accessory: high precision digital indicators (code 2140-6, 2140-6WL)

Code	Stem hole	Diameter range	Workpiece length	Accuracy
4741-40	Ø8mm	Ø3-40mm	15-300mm	2µm
4741-41	Ø28mm	Ø3-40mm	15-300mm	2µm

BENCH CENTERS

POPULAR MODEL

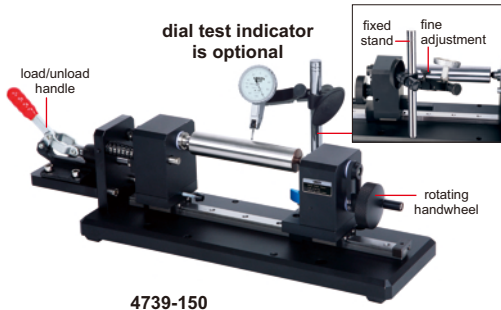

4739-150

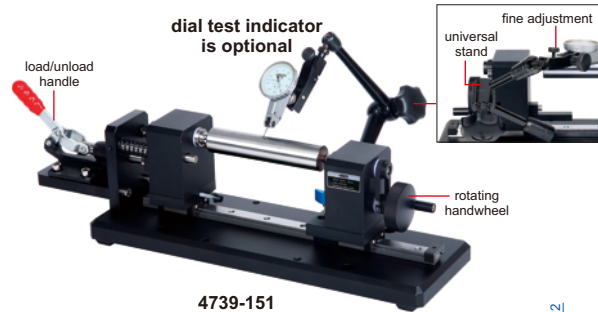

4739-151

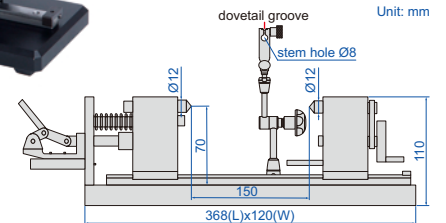

- Quick positioning, suitable for mass measurement
- Suitable for cylinders with outside diameter Ø3-140mm or inside diameter Ø1-12mm
- Supplied with standard rod to verify accuracy
- Optional accessory: dial test indicators

Code	Center height	Distance between two centers	Runout accuracy	Weight	Load	Remark
4739-150	70mm	150mm	2µm	6.5kg	15kg	fixed stand, high accuracy, inconvenient operation
4739-151	70mm	150mm	2µm	6.5kg	15kg	universal stand, low accuracy, convenient operation

BENCH CENTERS

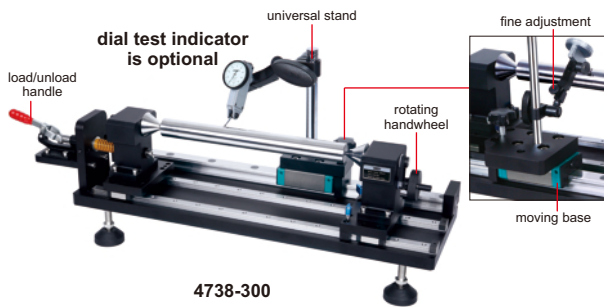

4738-300

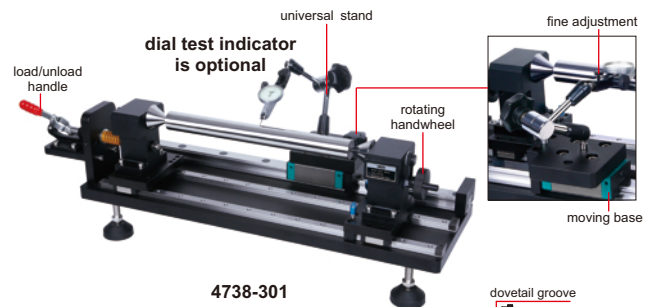

4738-301

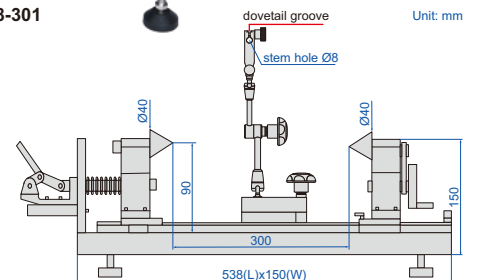
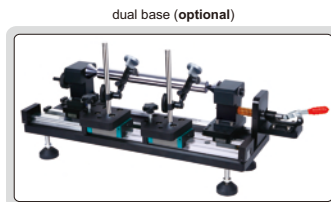

- Quick positioning, suitable for mass measurement
- Suitable for cylinders with outside diameter Ø3-180mm or inside diameter Ø1-40mm
- Supplied with standard rod to verify accuracy
- Optional accessory: dial test indicators

Code	Center height	Distance between two centers	Runout accuracy	Weight	Load	Remark
4738-300	90mm	300mm	2µm	15kg	20kg	fixed stand, high accuracy, inconvenient operation
4738-301	90mm	300mm	2µm	15kg	20kg	universal stand, low accuracy, convenient operation

standard rod (included)



VERTICAL BENCH CENTER

- Runout accuracy: 2µm
- Distance between two centers (L): 360mm
- Diameter of center (Ød): 24.1mm
- Taper of center: MT3
- Hardened cast-iron guide surface
- Use handwheel to move the tailstock
- Optional accessory: magnetic stands, dial test indicators

Code	Parallelism*	Center height (H)	Weight	Load
4728-360	0.01mm	130mm	85kg	80kg

*Parallelism of two centers to the guide surface

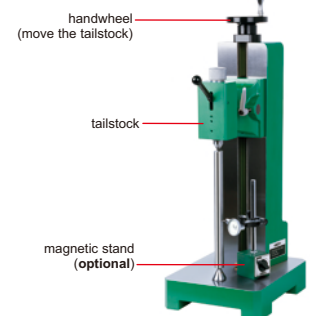
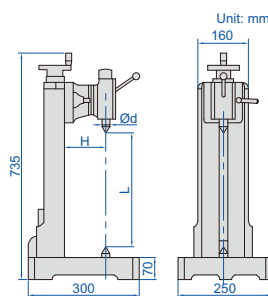

4728-360



Feeler Gages
Page 122-123



Pitch Gages
Page 123



Center Gages
Page 124

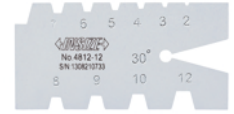

Thread Gages
Page 124



Angle Gages
Page 124



Radius Gages
Page 125



Drill Gages
Page 125



Angle Gages
Page 125

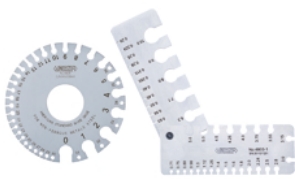

Wire Gages
Page 126

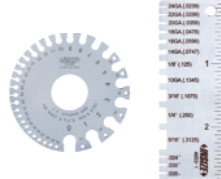

Thickness Gages
Page 126



Taper Slot Gages
Page 127



Taper Gages
Page 127



Taper Bore Gages
Page 128



Welding Gages
Page 128



Fillet Welding Gages
Page 129/132



Welding Gages
Page 129-131



Pipe Welding Gages
Page 132



Inside/Outside Calipers
Page 133



Dividers
Page 133



Digital Measuring Wheels
Page 134



Measuring Wheels
Page 134

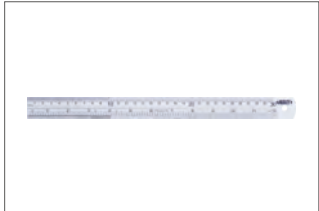

Steel Rules
Page 135



Combination Squares
Page 136



Plastic Angle Squares
Page 136



T-bevels
Page 136

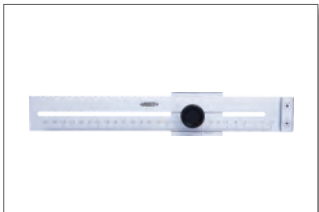

Marking Gages
Page 137

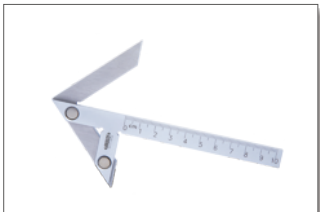

Center Marking Gages
Page 137



Scribing Calipers
Page 138



Height Scriber
Page 138



Scribers
Page 138



Precision Screwdriver Sets
Page 138



Measuring Tool Sets
Page 138

FEELER GAGE



4601-25

- Range: 0.04-1.00mm
- Made of hardened alloy steel
- Meet DIN2275/grade TC1
- Accuracy: $\pm(3+T/80)$ μm , 'T' is the thickness of leaves in μm

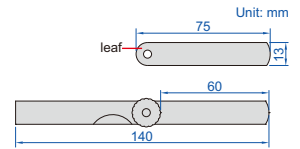

Code	Thickness of leaves included (mm)	Quantity of leaves
4601-25	0.04, 0.05, 0.06, 0.07, 0.08, 0.09, 0.10, 0.15, 0.20, 0.25, 0.30, 0.35, 0.40, 0.45, 0.50, 0.55, 0.60, 0.65, 0.70, 0.75, 0.80, 0.85, 0.90, 0.95, 1.00	25

FEELER GAGES

- Made of hardened alloy steel
- Meet DIN2275/grade TC1
- Accuracy: $\pm(3+T/80)$ μm , 'T' is the thickness of leaves in μm



4602-20

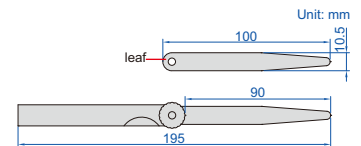

Code	Range	Thickness of leaves included (mm)	Quantity of leaves
4602-13A	0.03-0.50mm	0.03, 0.04, 0.05, 0.06, 0.07, 0.08, 0.09, 0.10, 0.15, 0.20, 0.30, 0.40, 0.50	13
4602-13	0.05-1.00mm	0.05, 0.10, 0.15, 0.20, 0.25, 0.30, 0.40, 0.50, 0.60, 0.70, 0.80, 0.90, 1.00	13
4602-17	0.02-1.00mm	0.02, 0.03, 0.04, 0.05, 0.06, 0.07, 0.08, 0.09, 0.10, 0.15, 0.20, 0.25, 0.30, 0.40, 0.50, 0.75, 1.00	17
4602-20	0.05-1.00mm	0.05, 0.10, 0.15, 0.20, 0.25, 0.30, 0.35, 0.40, 0.45, 0.50, 0.55, 0.60, 0.65, 0.70, 0.75, 0.80, 0.85, 0.90, 0.95, 1.00	20
4602-28	0.05-1.00mm	0.05, 0.06, 0.07, 0.08, 0.09, 0.10, 0.11, 0.12, 0.13, 0.14, 0.15, 0.20, 0.25, 0.30, 0.35, 0.40, 0.45, 0.50, 0.55, 0.60, 0.65, 0.70, 0.75, 0.80, 0.85, 0.90, 0.95, 1.00	28
4602-32	0.03-1.00mm	0.03, 0.04, 0.05, 0.06, 0.07, 0.08, 0.09, 0.10, 0.13, 0.15, 0.18, 0.20, 0.23, 0.25, 0.28, 0.30, 0.33, 0.35, 0.38, 0.40, 0.45, 0.50, 0.55, 0.60, 0.63, 0.65, 0.70, 0.75, 0.80, 0.85, 0.90, 1.00	32

LONG FEELER GAGES

- Range: 0.05-1.00mm
- Made of hardened alloy steel
- Meet DIN2275/grade TC1
- Accuracy: $\pm(3+T/80)$ μm , 'T' is the thickness of leaves in μm



4605-20

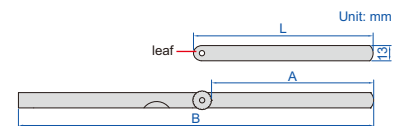

Code	Thickness of leaves included (mm)	Quantity of leaves	L	A	B
4605-13	0.05, 0.10, 0.15, 0.20, 0.25, 0.30, 0.40, 0.50, 0.60, 0.70, 0.80, 0.90, 1.00	13	150mm	135mm	295mm
4605-131		13	200mm	185mm	395mm
4605-132		13	300mm	285mm	590mm
4605-20	0.05, 0.10, 0.15, 0.20, 0.25, 0.30, 0.35, 0.40, 0.45, 0.50, 0.55, 0.60, 0.65, 0.70, 0.75, 0.80, 0.85, 0.90, 0.95, 1.00	20	150mm	135mm	295mm
4605-201		20	200mm	185mm	395mm
4605-202		20	300mm	285mm	590mm

PLASTIC FEELER GAGE

- Accuracy: $\pm 0.02\text{mm}$ (thickness of leaves: 0.05-0.1mm)
- $\pm 0.03\text{mm}$ (thickness of leaves: 0.15-0.6mm)
- $\pm 0.04\text{mm}$ (thickness of leaves: $\geq 0.7\text{mm}$)

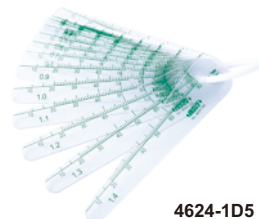

4624-1D5

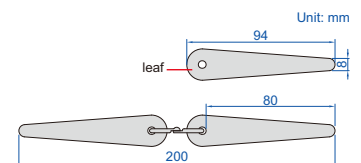

Code	Range	Thickness of leaves included (mm)	Quantity of leaves
4624-1D5	0.05-1.5mm	0.05, 0.1, 0.15, 0.2, 0.3, 0.4, 0.5, 0.6, 0.7, 0.8, 0.9, 1.0, 1.1, 1.2, 1.3, 1.4, 1.5	17

FEELER GAGE ROLLS



4621-30

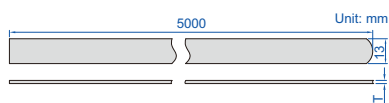

- Used as shims to accurately set spacing
- Made of hardened alloy steel
- Length 5m
- Width 13mm

Code	Thickness (T)	Accuracy
4621-02	0.02mm	±4µm
4621-03	0.03mm	±4µm
4621-04	0.04mm	±4µm
4621-05	0.05mm	±4µm
4621-06	0.06mm	±4µm
4621-07	0.07mm	±5µm
4621-08	0.08mm	±5µm
4621-09	0.09mm	±5µm
4621-10	0.10mm	±5µm
4621-12	0.12mm	±5µm
4621-15	0.15mm	±6µm
4621-18	0.18mm	±7µm
4621-20	0.20mm	±8µm
4621-25	0.25mm	±9µm

Code	Thickness (T)	Accuracy
4621-30	0.30mm	±9µm
4621-35	0.35mm	±11µm
4621-40	0.40mm	±12µm
4621-45	0.45mm	±12µm
4621-50	0.50mm	±14µm
4621-55	0.55mm	±14µm
4621-60	0.60mm	±14µm
4621-65	0.65mm	±14µm
4621-70	0.70mm	±17µm
4621-75	0.75mm	±17µm
4621-80	0.80mm	±19µm
4621-85	0.85mm	±19µm
4621-90	0.90mm	±22µm
4621-95	0.95mm	±22µm
4621-100	1.00mm	±24µm

PITCH GAGES

- Identify the pitch of screw thread
- Made of medium carbon steel



4820-452

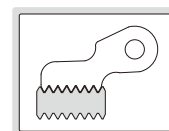

Metric 60° and Whitworth 55° screw

Code	Range	Pitch of leaves included	Quantity of leaves
4820-452	0.25-6mm	0.25, 0.3, 0.35, 0.4, 0.45, 0.5, 0.6, 0.7, 0.75, 0.8, 0.9, 1, 1.25, 1.5, 1.75, 2, 2.5, 3, 3.5, 4, 4.5, 5, 5.5, 6mm	52
	4-62TPI	4, 4-1/2, 5, 6, 7, 8, 9, 10, 11, 12, 13, 14, 16, 18, 19, 20, 22, 24, 25, 26, 28, 30, 32, 36, 40, 48, 60, 62TPI	

Metric 60° and Unified 60° screw

Code	Range	Pitch of leaves included	Quantity of leaves
4820-552	0.4-7mm	0.4, 0.5, 0.6, 0.7, 0.75, 0.8, 0.9, 1, 1.25, 1.5, 1.75, 2, 2.5, 3, 3.5, 4, 4.5, 5, 5.5, 6, 6.5, 7mm	52
	4-42TPI	4, 4-1/2, 5, 5-1/2, 6, 7, 8, 9, 10, 11, 11-1/2, 12, 13, 14, 15, 16, 18, 20, 22, 24, 26, 27, 28, 30, 32, 34, 36, 38, 40, 42TPI	

PITCH GAGE

- Accuracy: ±0.07mm
- Check the pitch of screw thread
- Made of medium carbon steel



4824-12

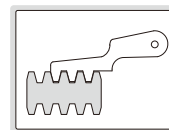

Code	Range	Thread type	Pitch of leaves included	Quantity of leaves
4824-12	2-20mm	Tr30°	2, 3, 4, 5, 6, 7, 8, 9, 10, 12, 16, 20mm	12

CENTER GAGES

- To check and set screw cutting tools, and check the angle and pitch of screw thread
- Angle accuracy: $\pm 30\text{min}$
- Made of stainless steel

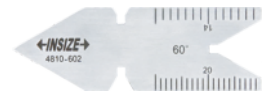
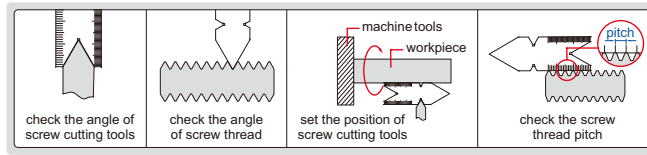

4810-602

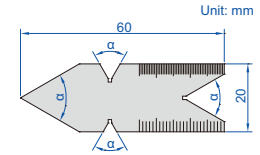

Code	Thread type	Angle (α)	Graduation
4810-601	METRIC 60°	60°	0.5mm and 1mm
4810-602	UNIFIED 60°	60°	14ths and 20ths on front side, 24ths and 32ths on back side

THREAD GAGE

- Pitch: 2, 3, 4, 5, 6, 7, 8, 9, 10, 12mm
- To check and set screw cutting tools
- Made of medium carbon steel

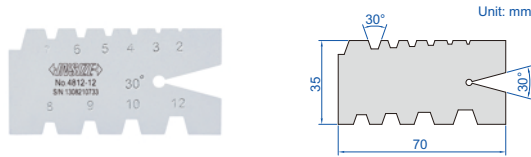

4812-12

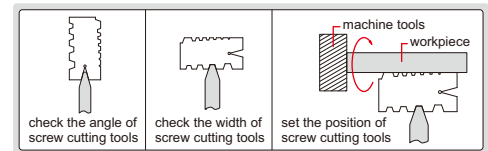

Code	Range	Thread type
4812-12	2-12mm	Tr 30°

ANGLE GAGE

- Accuracy: $\pm 30'$
- To check complementary angles
- Made of stainless steel



4806-20

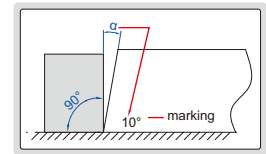

Code	Range (α)	Angle of leaves included	Quantity of leaves
4806-20	1°-45°	1°, 2°, 3°, 4°, 5°, 6°, 7°, 8°, 9°, 10°, 12°, 14°, 16°, 18°, 20°, 25°, 30°, 35°, 40°, 45°	20

ANGLE GAGE SET

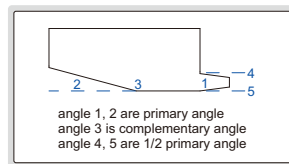

type A

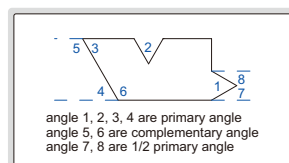

type B



4807

Primary angle	1/2 primary angle	Complementary angle	Type
5°	2°30'	175°	A
10°	5°	170°	A
15°	7°30'	165°	A
20°	10°	160°	B
25°	12°30'	155°	B
30°	15°	150°	B
35°	17°30'	145°	B
40°	20°	140°	B
45°	22°30'	135°	B
50°	25°	130°	B
55°	27°30'	125°	B
60°	30°	120°	B
65°	32°30'	115°	B
70°	35°	110°	B
75°	37°30'	105°	B
80°	40°	100°	B
85°	42°30'	95°	B
90°	45°	90°	B

- Each blade checks primary, 1/2 primary and complementary angles
- Made of medium carbon steel

Code	Quantity of leaves	Accuracy
4807	18	$\pm 10'$

RADIUS GAGES



4801-17

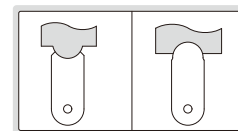

- Made of medium carbon steel

Code	Range	Radius of leaves included (mm)	Quantity of leaves (internal+external)
4801-17	1-7mm	1, 1.25, 1.5, 1.75, 2, 2.25, 2.5, 2.75, 3, 3.5, 4, 4.5, 5, 5.5, 6, 6.5, 7	17+17
4801-16	7.5-15mm	7.5, 8, 8.5, 9, 9.5, 10, 10.5, 11, 11.5, 12, 12.5, 13, 13.5, 14, 14.5, 15	16+16
4801-15	15.5-25mm	15.5, 16, 16.5, 17, 17.5, 18, 18.5, 19, 19.5, 20, 21, 22, 23, 24, 25	15+15

RADIUS GAGE SET

- Each piece has 3 concave and 2 convex gaging surfaces
- Supplied with handle
- Made of medium carbon steel

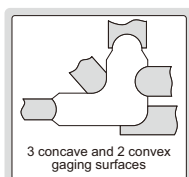

4804-26



Code	Range	Radius of leaves included (mm)	Quantity of leaves
4804-26	0.5-13mm	0.5, 1, 1.5, 2, 2.5, 3, 3.5, 4, 4.5, 5, 5.5, 6, 6.5, 7, 7.5, 8, 8.5, 9, 9.5, 10, 10.5, 11, 11.5, 12, 12.5, 13	26

DRILL POINT GAGE

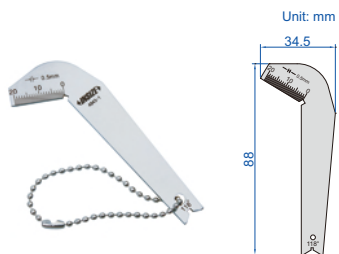
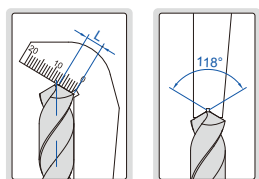

4843-1

- For twist drills with 118° angle, to check if the center of tip is concentric with the drill body
- Made of stainless steel

Code	Accuracy	
	Angle	Length
4843-1	±0.5°	±0.5mm

DRILL ANGLE GAGE



4842-1

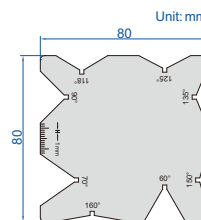

- Check drills with angle 60°, 70°, 90°, 118°, 125°, 135°, 150° or 160°
- Made of stainless steel

Code	Accuracy
4842-1	±0.5°

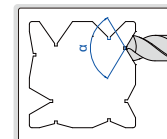

ANGLE GAGE

- Accuracy: ±10'
- Made of stainless steel

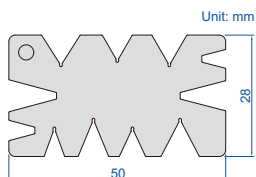

4854-1

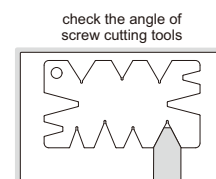

Code	Range
4854-1	29°, 30°, 40°, 45°, 50°, 55°, 60°

U.S. STANDARD SHEET METAL GAGE



4809

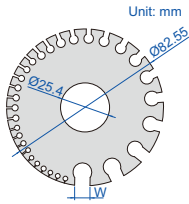

No.	W	No.	W
0	7.938mm/0.3125"	18	1.270mm/0.0500"
1	7.144mm/0.2813"	19	1.111mm/0.0438"
2	6.747mm/0.2656"	20	0.953mm/0.0375"
3	6.350mm/0.2500"	21	0.873mm/0.0344"
4	5.953mm/0.2344"	22	0.794mm/0.0313"
5	5.556mm/0.2188"	23	0.714mm/0.0281"
6	5.159mm/0.2031"	24	0.635mm/0.0250"
7	4.763mm/0.1875"	25	0.556mm/0.0219"
8	4.366mm/0.1719"	26	0.476mm/0.0188"
9	3.969mm/0.1563"	27	0.437mm/0.0172"
10	3.572mm/0.1406"	28	0.397mm/0.0156"
11	3.175mm/0.1250"	29	0.357mm/0.0141"
12	2.778mm/0.1094"	30	0.318mm/0.0125"
13	2.381mm/0.0938"	31	0.278mm/0.0109"
14	1.984mm/0.0781"	32	0.258mm/0.0102"
15	1.786mm/0.0703"	33	0.238mm/0.0094"
16	1.588mm/0.0625"	34	0.218mm/0.0086"
17	1.429mm/0.0563"	35	0.198mm/0.0078"
		36	0.179mm/0.0070"

- For gaging sheet metal, plate iron and steel
- Hardened to HRC50-57

Code	Range
4809	0-36 (7.938-0.179mm/0.3125-0.0070")

AMERICAN STANDARD WIRE GAGE



4808

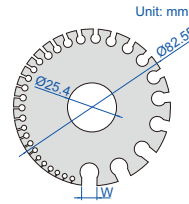

No.	W	No.	W
0	8.250mm/0.3249"	18	1.020mm/0.0403"
1	7.350mm/0.2893"	19	0.912mm/0.0359"
2	6.540mm/0.2576"	20	0.813mm/0.0320"
3	5.830mm/0.2294"	21	0.724mm/0.0285"
4	5.190mm/0.2043"	22	0.643mm/0.0253"
5	4.620mm/0.1819"	23	0.574mm/0.0226"
6	4.110mm/0.1620"	24	0.511mm/0.0201"
7	3.670mm/0.1443"	25	0.440mm/0.0179"
8	3.260mm/0.1285"	26	0.404mm/0.0159"
9	2.910mm/0.1144"	27	0.361mm/0.0142"
10	2.590mm/0.1019"	28	0.320mm/0.0126"
11	2.300mm/0.0907"	29	0.287mm/0.0113"
12	2.050mm/0.0808"	30	0.254mm/0.0100"
13	1.820mm/0.0720"	31	0.226mm/0.0089"
14	1.630mm/0.0641"	32	0.203mm/0.0080"
15	1.450mm/0.0571"	33	0.180mm/0.0071"
16	1.290mm/0.0508"	34	0.160mm/0.0063"
17	1.150mm/0.0453"	35	0.142mm/0.0056"
		36	0.127mm/0.0050"

- For gaging non-ferrous wire and metals such as copper, brass and aluminum
- Hardened to HRC50-57

Code	Range
4808	0-36 (8.250-0.127mm/0.3249-0.0050")

WIRE GAGE

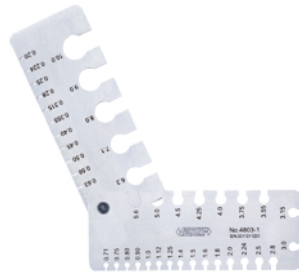
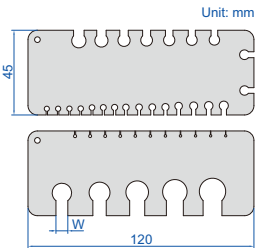

4803-1

- For gaging non-ferrous wire and metals such as copper, brass and aluminum
- Hardened to HRC51-53
- Including 2 pcs wire gages

Code	Range
4803-1	0.2-10mm

Wire diameter (W)	Wire diameter (W)	Wire diameter (W)
0.200mm	0.900mm	3.55mm
0.224mm	1.000mm	3.75mm
0.250mm	1.120mm	4.00mm
0.280mm	1.250mm	4.25mm
0.315mm	1.400mm	4.50mm
0.355mm	1.500mm	5.00mm
0.400mm	1.60mm	5.60mm
0.450mm	1.80mm	6.30mm
0.500mm	2.00mm	7.10mm
0.560mm	2.24mm	8.00mm
0.630mm	2.50mm	9.00mm
0.710mm	2.80mm	10.00mm
0.750mm	3.00mm	
0.800mm	3.15mm	

THICKNESS GAGE

- Made of stainless steel

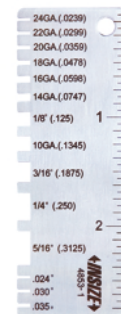
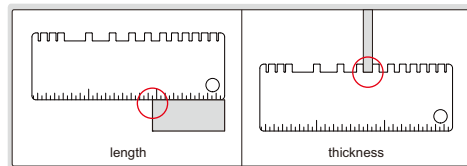

4853-1

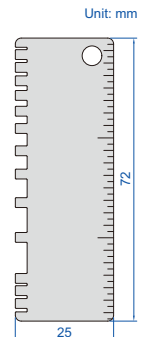

Code	Measurement	Range	Graduation	Accuracy
4853-1	length	0-2 3/4"	1/16"	1/32"
	thickness	24GA.(0.0239"), 22GA.(0.0299"), 20GA.(0.0359")	—	±0.002"
		18GA.(0.0478"), 16GA.(0.0598"), 14GA.(0.0747"), 1/8"(0.125"), 10GA.(0.1345"), 3/16"(0.1875"), 1/4"(0.250"), 5/16"(0.3125")		±0.004"
		0.024", 0.030", 0.035"		±0.002"

DIGITAL TAPER SLOT GAGES

DATA
OUTPUT

DIRECT READING,
CALCULATION IS NOT REQUIRED

- Non waterproof
- Measuring opening, slot width
- Resolution: 0.01mm/0.0005"
- Buttons: on/off, zero, mm/inch
- Automatic power off, move the digital unit to turn on power
- Battery CR2032, data output
- Made of stainless steel
- Optional accessory: data output cable (code 7315-21 receiver is needed, 7302-21)



1160-10

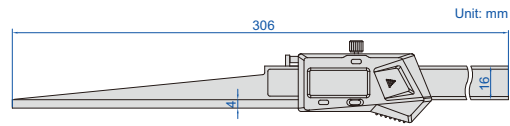

1160-10

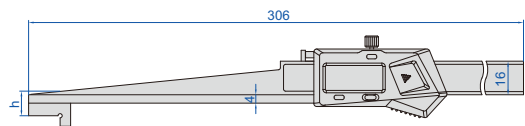

1160-20, 1160-30, 1160-40

measure slot width

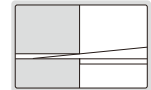

Code	Range	Accuracy	h
1160-10	0.2-10mm/0.01-0.39"	±0.03mm	—
1160-20	10-20mm/0.39-0.79"	±0.05mm	10mm
1160-30	20-30mm/0.79-1.18"	±0.05mm	20mm
1160-40	30-40mm/1.18-1.58"	±0.05mm	30mm

TAPER SLOT GAGES

- For quick measurement of slot width
- Satin chrome plated reading surface
- Made of stainless steel



4630-1

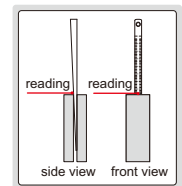
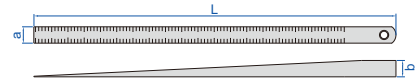

Code	Range	Graduation	Accuracy	L	a	b
4630-3	0.4-6mm	0.05mm	±0.04mm	164mm	12.5mm	6.5mm
4630-1	0.5-10mm	0.05mm	±0.07mm	220mm	10mm	10.5mm
4630-2	0.5-15mm	0.1mm	±0.08mm	184mm	12.5mm	16.5mm

TAPER GAGES

measure slot width

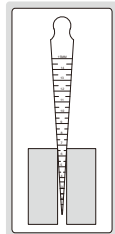

measure diameter of hole

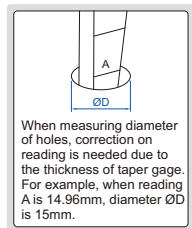

When measuring diameter of holes, correction on reading is needed due to the thickness of taper gage. For example, when reading A is 14.96mm, diameter ØD is 15mm.

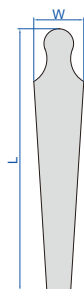

front back
4833-2

- Measure opening, slot width, hole diameter, etc.
- Diameter correction table on the back (only for 4833-1, 4833-2)
- Made of stainless steel

Code	Range	Accuracy	Graduation	L	W
4833-1	0.8-15mm	±0.05mm	0.1mm	146mm	17mm
4833-2	15-30mm	±0.05mm	0.1mm	159mm	30.4mm
4833-3	30-45mm	±0.05mm	0.1mm	166mm	45.4mm
4833-4	45-60mm	±0.05mm	0.1mm	170mm	60.5mm

TAPER GAGE SET



front

4837-1

back

measure slot width

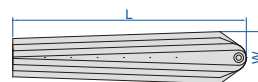
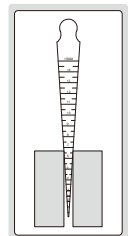

- Accuracy: ±0.05mm
- Include 4 pcs (1-8mm, 8-15mm, 15-22mm, 22-29mm)
- Measure opening, slot width, hole diameter, etc.
- Diameter correction table on the back
- Made of stainless steel

Code	Range	Graduation	L	W
4837-1	1-29mm	0.05mm	133mm	29.6mm

measure diameter of hole

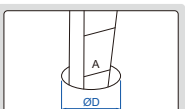

When measuring diameter of holes, correction on reading is needed due to the thickness of taper gage. For example, when reading A is 14.96mm, diameter ØD is 15mm.

TAPER BORE GAGES

- Quick measurement of bore diameter
- Hardened steel, HRC50-58
- Satin chrome plated surface
- Aluminium oxidized handle

Code	Range	Accuracy	Graduation	L	Ød1	Ød2
4852-1	1-6.5mm	±0.05mm	0.1mm	62.5mm	7mm	0.8mm
4852-3	3-16mm	±0.05mm	0.1mm	143mm	17mm	2.8mm
4852-15	15-30mm	±0.05mm	0.1mm	165mm	31mm	14.7mm
4852-30	30-45mm	±0.05mm	0.1mm	165mm	46mm	29.6mm
4852-45	45-60mm	±0.05mm	0.1mm	167mm	61mm	44.3mm



4852-15

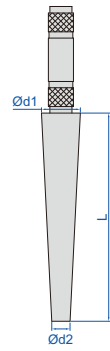

SMALL TAPER BORE GAGE

- Quick measurement of small bore diameter
- Hardened working face
- Supplied with protection cap

Code	Range	Graduation	Accuracy
4855-5	0.1-5mm	0.01mm	±0.03mm



4855-5

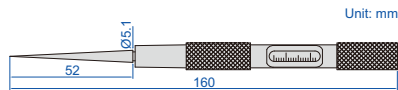

supplied with protection cap



WELDING GAGE

- Made of stainless steel
- Satin chrome plated reading surface

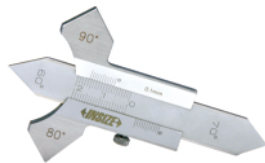

4830

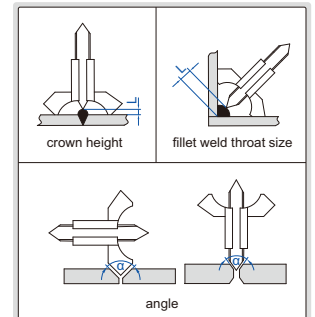
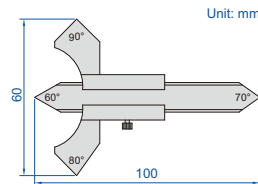

Code	Measurement	Range	Graduation	Accuracy
4830	crown height	0-8mm	0.1mm	±0.1mm
	fillet weld throat size	0-20mm	0.1mm	±0.3mm
	angle	60°, 70°, 80°, 90°	—	±1°

DIGITAL WELDING GAGE

ATTENTION: NO DATA OUTPUT

- Non waterproof
- Buttons: zero, mm/inch, on/off
- Battery LR44
- Made of stainless steel



4831-20A

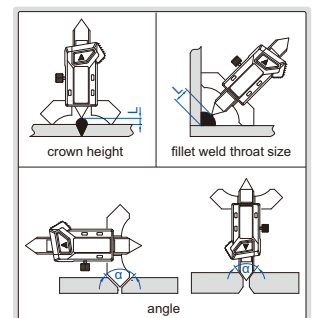
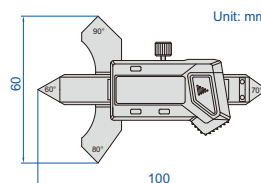

Code	Measurement	Range	Resolution	Accuracy
4831-20A	crown height	0-7mm	0.01mm/0.0005"	±0.03mm
	fillet weld throat size	0-20mm	0.01mm/0.0005"	±0.1mm
	angle	60°, 70°, 80°, 90°	—	±1°

FILLET WELDING GAGE

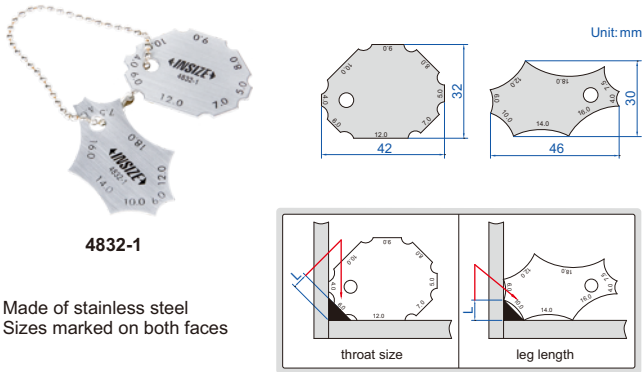

4832-1

- Made of stainless steel
- Sizes marked on both faces

Code	Accuracy	Throat size (mm)	Leg length (mm)
4832-1	±0.5mm	4, 5, 6, 7, 8, 9, 10, 12	4, 6, 7.5, 10, 12, 14, 16, 18

FILLET WELDING GAGE

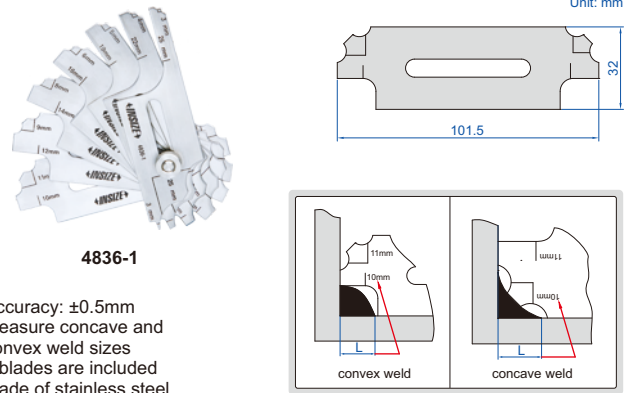

4836-1

- Accuracy: ±0.5mm
- Measure concave and convex weld sizes
- 7 blades are included
- Made of stainless steel

Code	Accuracy	Size (mm)
4836-1	±0.5mm	3, 4, 5, 6, 8, 9, 10, 11, 12, 14, 16, 19, 22, 25

FILLET WELDING GAGE

- Measure convex weld sizes
- 3 blades are included
- Made of stainless steel

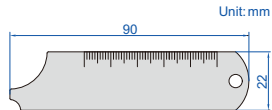

4847-1

Code	Measurement	Range	Graduation	Accuracy
4847-1	convex weld size	4, 6, 8, 10, 12, 14mm	—	±0.5mm
	length	0-50mm	1mm	±0.5mm

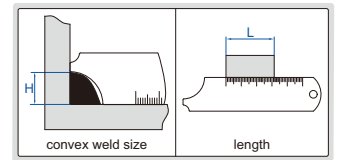

WELDING GAGE



4834-1

- Pointer can be locked for later reference
- Made of stainless steel

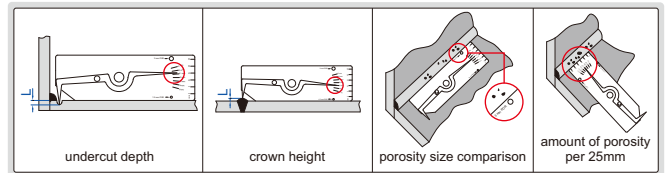
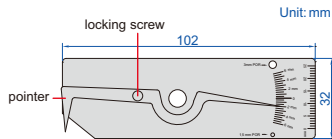

Code	Measurement	Range	Graduation	Accuracy
4834-1	undercut depth	0-6mm	0.5mm	±0.5mm
	crown height	0-6mm	0.5mm	±0.5mm
	porosity size comparison	1.5mm, 3mm	—	±0.2mm
	amount of porosity per 25mm	25mm	1mm	—

WELDING GAGE

- Made of stainless steel

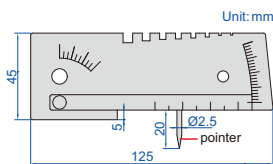

4848-1

Code	Measurement	Range	Graduation	Accuracy
4848-1	misalignment (high-low)	-5mm~+15mm	1mm	±0.5mm
	angle of preparation	0°-45°	5°	±2.5°
	length	0-50mm	1mm	±0.5mm
	gap	1-4mm	0.5mm	±0.25mm
	thickness	1, 1.2, 2.0, 2.5, 3.0, 3.25, 4.0, 5.0mm	—	±0.1mm

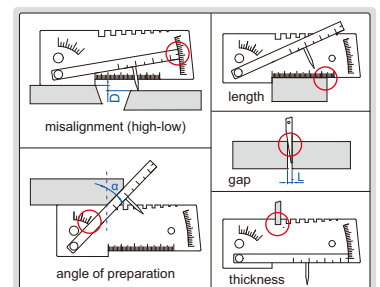

WELDING GAGE

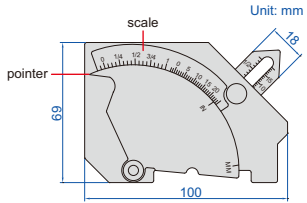

front

4835-1

back

- Adjustable scale to compensate pointer wear
- Made of stainless steel

Code	Measurement	Range	Graduation	Accuracy
4835-1	crown height	0-25mm (0-1")	1mm (1/16")	±0.5mm
	fillet weld leg height	0-25mm (0-1")	1mm (1/16")	±0.5mm
	misalignment (high-low)	0-25mm (0-1")	1mm (1/16")	±0.5mm
	undercut depth	0-2mm (0-1/8")	1mm (1/16")	±0.5mm
	fillet weld throat size	0-20mm (0-3/4")	1mm (1/16")	±0.5mm
	angle of preparation	0-60°	5°	±1°
	length	0-60mm (0-2")	1mm (1/16")	±0.5mm
	45° angle	—	—	±1°

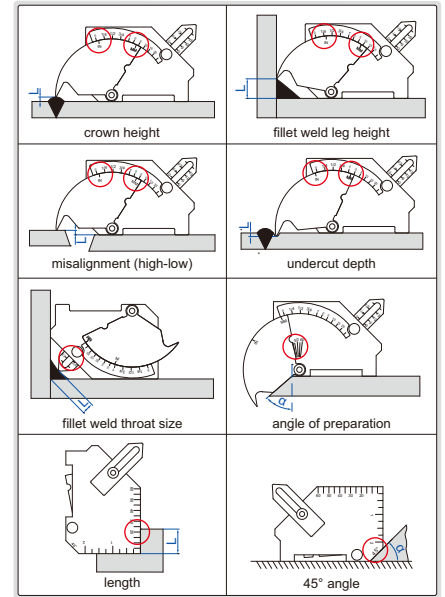

WELDING GAGE

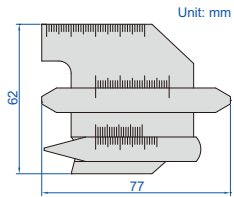

front

4838-1

back

- Made of stainless steel

Code	Measurement	Range	Graduation	Accuracy
4838-1	crown height	0-10mm	1mm	±0.5mm
	leg height	0-14mm	1mm	±0.5mm
	undercut depth	0-5mm	0.05mm	±0.05mm
	throat size	0-13mm	1mm	±0.5mm
	weld length	0-40mm	1mm	±1mm
	angle	90°-150°	5°	±1°
	gap	0.5-5mm	1mm	±0.5mm
	length	0-40mm	1mm	±0.5mm

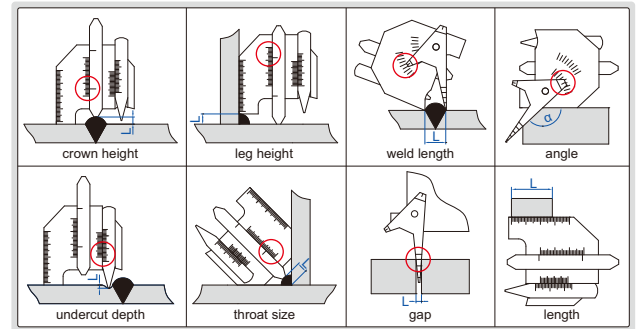

WELDING GAGE

- Accuracy: ±0.5mm
- Made of stainless steel

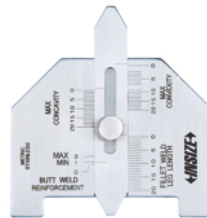
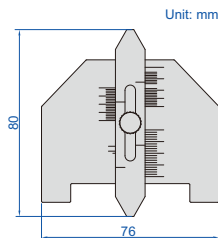

4851-1

Code	Measurement	Range	Graduation
4851-1	leg height	0-20mm	1mm
	crown height	0-3mm	—
	theoretical leg height of convex weld	0-20mm	1mm
	theoretical leg height of concave weld	0-20mm	1mm

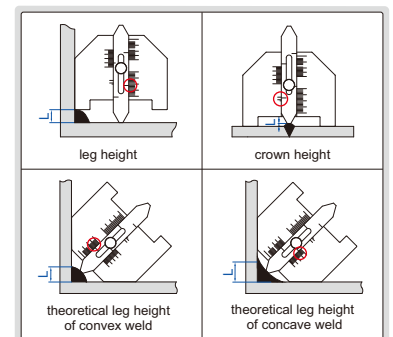

WELDING GAGE

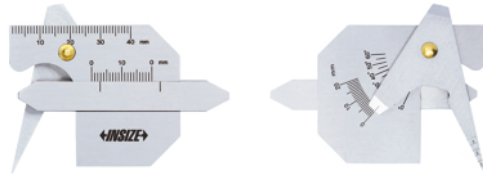
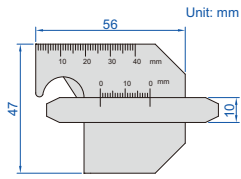

front **6832-1** back

- Made of stainless steel
- Satin chrome plated surface

Code	Measurement	Range	Graduation	Accuracy
6832-1	leg length	0-20mm	1mm	±0.3mm
	leg height	0-20mm	1mm	±0.3mm
	crown height	0-20mm	1mm	±0.3mm
	throat size	0-10mm	1mm	±0.3mm
	angle	0°-60°	5°	±1°
	gap	1-3.5mm	0.5mm	±0.2mm
	length	0-40mm	1mm	±0.3mm

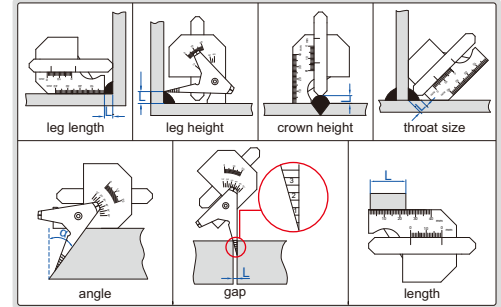

WELDING GAGE

- Made of stainless steel

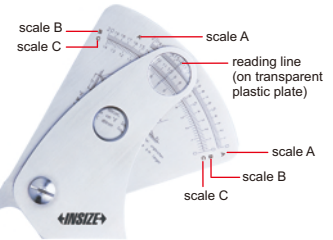
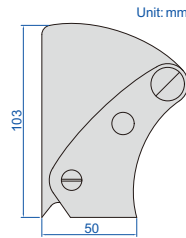
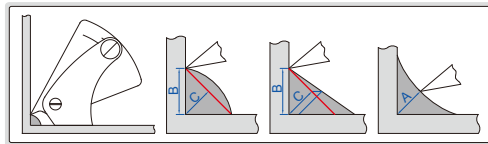

4840-1

Code	Graduation	Accuracy
4840-1	0.2mm	±0.3mm

WELDING GAGE

- Made of stainless steel



4850-1

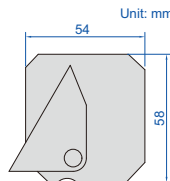

Code	Measurement	Range	Graduation	Accuracy
4850-1	leg height (b)	0-18mm	1mm	±0.5mm
	theoretical throat size (a)	2-12mm	1mm	±0.5mm
	throat size	4, 5, 6, 7mm	—	±0.5mm
	angle of preparation	50°, 60°	—	±1°
	thickness	1.5, 2, 3.5mm	—	±0.2mm

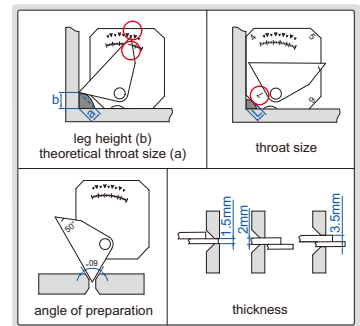

WELDING UNDERCUT GAGE



4849-1

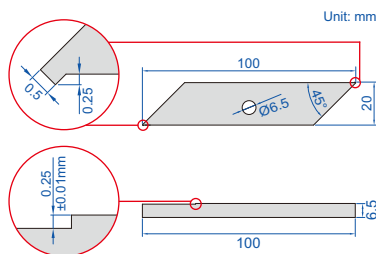

- Measure undercut
- Calibration block is included
- Made of stainless steel

Code
4849-1

calibration block (included)

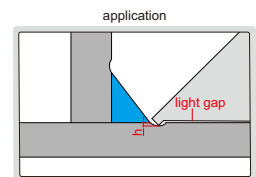

when there is a light gap, $h < 0.25\text{mm}$;
when there is no light gap, $h \geq 0.25\text{mm}$

FILLET WELDING GAGE

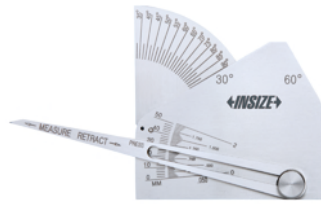
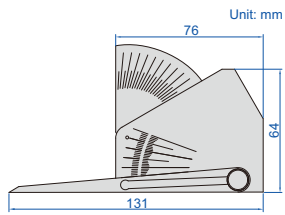

4846-1

- Calculating card is included
- Made of stainless steel

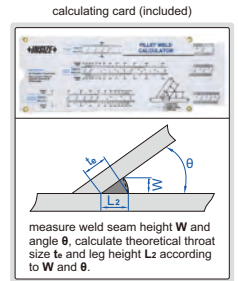
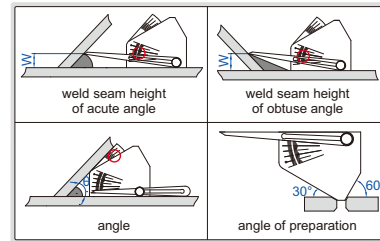

Code	Measurement	Range	Graduation	Accuracy
4846-1	weld seam height W	0-50mm/0-2"	2mm/0.05"	±1mm
	angle θ	30°~90°	2.5°	±1°
	60° angle	—	—	±0.5°

PIPE WELDING GAGE

- Made of stainless steel

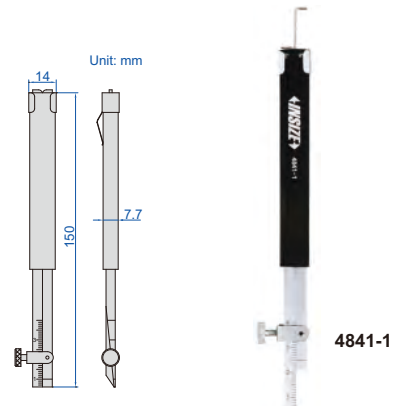
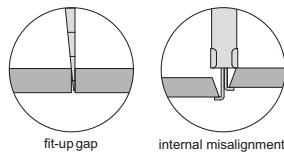

4841-1

Code	Measurement	Range	Graduation	Accuracy
4841-1	internal misalignment	0-30mm	1mm	±0.5mm
	fit-up gap	0.7-4mm	0.1mm	±0.1mm

PIPE WELDING GAGE

- Made of stainless steel

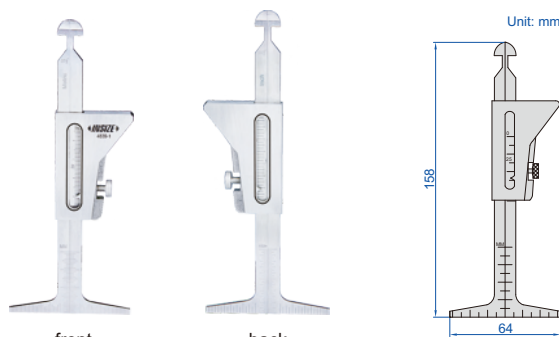

front

back

4839-1

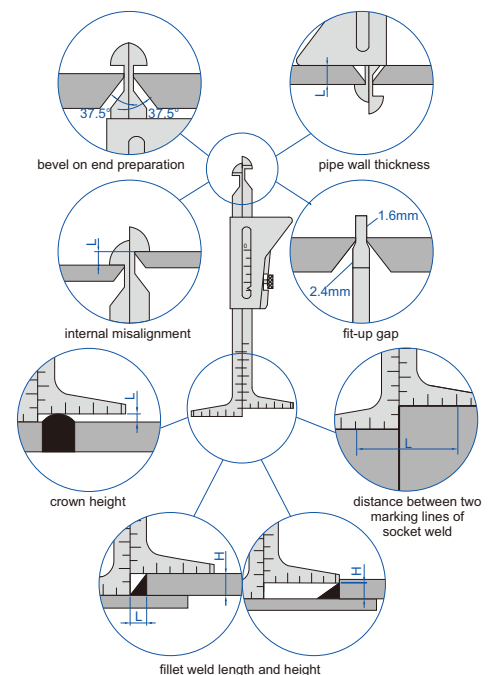

Code	Measurement	Range	Graduation	Accuracy
4839-1	bevel on end preparation	37.5°	—	±1°
	pipe wall thickness	0-45mm (0~1-3/4")	1mm (1/16")	±0.5mm
	internal misalignment	0-35mm (0~1-3/8")	1mm (1/32")	±0.5mm
	fit-up gap	1.6mm, 2.4mm	—	±0.5mm
	crown height	0-35mm (0~1-3/8")	1mm (1/32")	±0.1mm
	distance between two marking lines of socket weld	0-60mm (0~2-3/8")	1mm (1/16")	±0.5mm
	fillet weld length	0-30mm (0~1-1/4")	1mm (1/16")	±0.5mm
	fillet weld height	0-35mm (0~1-3/8")	1mm (1/32")	±0.5mm

6-PIECE WELDING GAGE SET

- Includes:
 - 1) Welding gage (code **4834-1**)
 - 2) Fillet welding gage, size 3~25mm, 7 blades (code **4836-1**)
 - 3) Pipe welding gage (code **4841-1**)
 - 4) Telescoping inspection mirror, size of mirror Ø32mm, length 178~505mm (code **7160-1**)
 - 5) Pocket rule with sliding clip, range 150mm/6", graduation 1mm, 1/64" (code **7119-150**)
 - 6) LED flashlight (code **ISGF-0501**)



5064

Code
5064

7-PIECE WELDING GAGE SET

- Includes:
 - 1) Welding gage (code **4834-1**)
 - 2) Welding gage (code **4851-1**)
 - 3) Pipe welding gage (code **4839-1**)
 - 4) Outside micrometer, range 0-25mm, graduation 0.01mm (code **3203-25A**)
 - 5) Telescoping inspection mirror, size of mirror Ø32mm, length 178~505mm (code **7160-1**)
 - 6) Magnifier with illumination, magnification 4X (code **7513-4**)
 - 7) Steel rule, range 150mm/6", graduation 0.5mm, 1mm, 1/64", 1/32", 1/16" (code **7110-150**)



5071

Code
5071

7-PIECE WELDING GAGE SET

- Includes:
 - 1) Welding gage (code **4834-1**)
 - 2) Welding gage (code **4851-1**)
 - 3) Fillet welding gage, size 3~25mm, 7 blades (code **4836-1**)
 - 4) Outside micrometer, range 0-25mm, graduation 0.01mm (code **3203-25A**)
 - 5) Digital caliper, range 0-150mm/0-6", resolution 0.01mm/0.005" (code **1108-150**)
 - 6) Pocket rule with sliding clip, range 150mm/6", graduation 1mm, 1/64" (code **7119-150**)
 - 7) Magnifier with illumination, magnification 4X (code **7513-4**)



5072

Code
5072

OUTSIDE SPRING CALIPERS

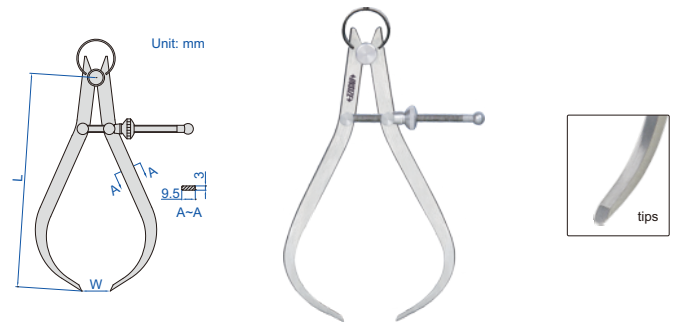

7262-150

- Made of carbon steel

Code	Size (L)	Range (W)
7262-150	150mm	0-140mm
7262-200	210mm	0-210mm
7262-300	310mm	0-320mm

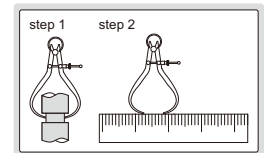

INSIDE SPRING CALIPERS

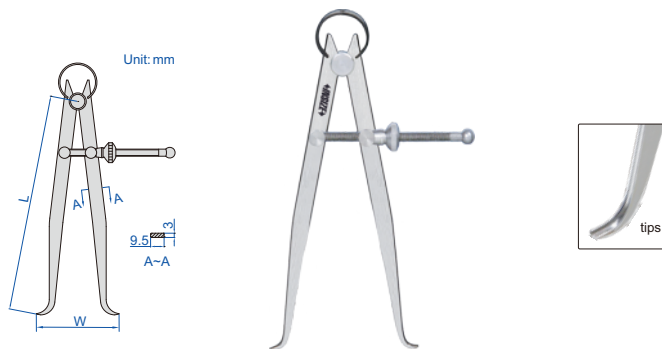

7261-150

- Made of carbon steel

Code	Size (L)	Range (W)
7261-150	150mm	20-170mm
7261-200	200mm	22-220mm
7261-300	300mm	30-320mm

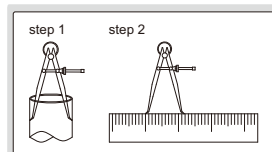

SPRING DIVIDERS

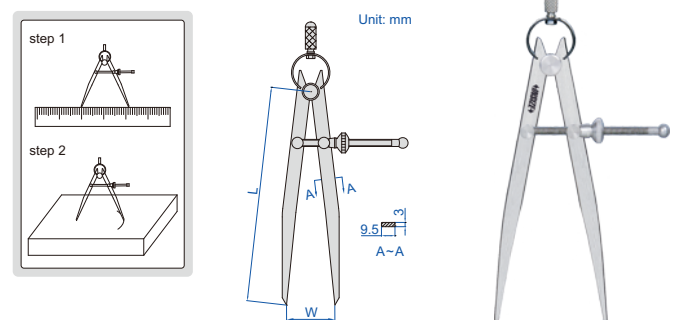

7260-150

- Made of carbon steel
- Hardened points

Code	Size (L)	Range (W)
7260-150	150mm	0-150mm
7260-200	200mm	0-210mm
7260-300	300mm	0-320mm

SELF ADHESIVE MEASURING ROLLS

- Self adhesive back
- Steel tape, non-glare coating, wear resistance

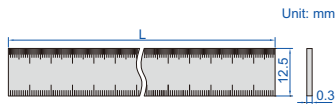

7139-50



type of reading

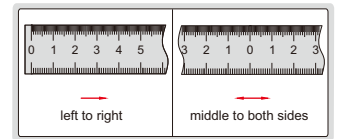

Code	Range (L)	Graduation	Accuracy	Type of reading
7139-50	50-0-50cm	1mm	±0.2mm	middle to both sides
7139-100	0-100cm	1mm	±0.4mm	left to right

DIGITAL MEASURING WHEEL

- IP40 dust/waterproof
- Measuring length of curve
- Four measurement modes: length, rectangle area, diameter of circle, cube
- Resolution: 0.001m/0.01ft
- Button function: on/off, mm/inch, one or two sides set, measurement mode conversion, measurement
- Battery CR2032, automatic power off



7146-10



IP40
WATERPROOF

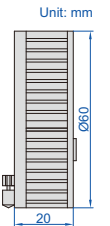
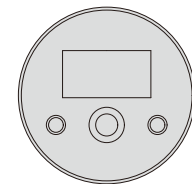

Code	Range	Accuracy
7146-10	0-10m/0-32.8ft	±0.3%L (L is the measured length)

MEASURING WHEEL (BASIC TYPE)

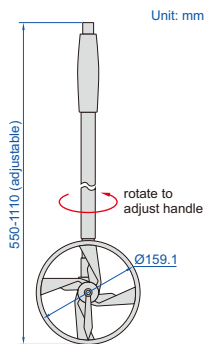

7144-1

- ABS plastic frame, wear-resistant PU tire
- Three-section adjustable handle

Code	Range	Resolution
7144-1	0.1-9999.9m	0.1m

MEASURING WHEEL

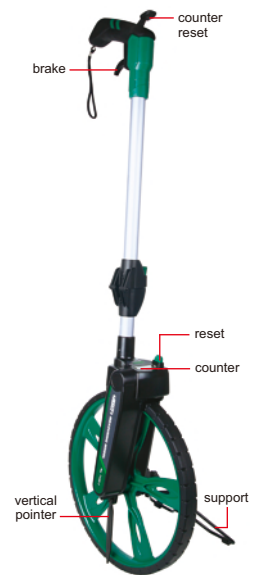
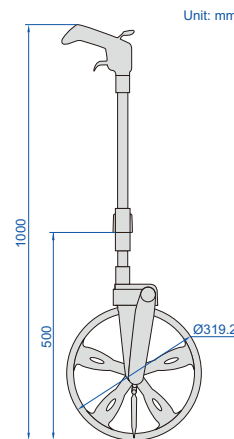

7145-1

- ABS plastic frame, wear-resistant PU tire
- Two-section foldable handle

Code	Range	Resolution
7145-1	0.1-9999.9m	0.1m

POCKET RULE WITH SLIDING CLIP

- Accuracy: $\pm 0.30\text{mm}$
- With sliding clip, clip can be inserted in the pocket, also can be used as depth gage base
- Inch/metric conversion table on the back
- Made of stainless steel



7119-150

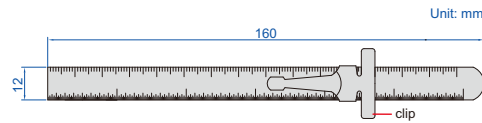

Code	Range	Graduation
7119-150	150mm/6"	1mm, 1/64"

STEEL RULES

POPULAR MODEL

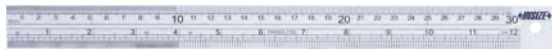

7110-300

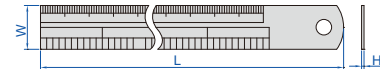

- Graduation: 0.5mm, 1mm, 1/64", 1/32", 1/16"
- Rigid rules
- Made of stainless steel
- Non-glare surface

1 pc per package

Code	Range	Accuracy	L	W	H	Remark
7110-150	150mm/6"	$\pm 0.18\text{mm}$	170	18	1.0	graduation on front and back
7110-200	200mm/8"	$\pm 0.18\text{mm}$	220	18	1.0	graduation on front and back
7110-300	300mm/12"	$\pm 0.27\text{mm}$	330	25	1.0	graduation on front and back
7110-3001	300mm/12"	$\pm 0.27\text{mm}$	325	30	1.0	graduation on front and back
7110-500	500mm/20"	$\pm 0.40\text{mm}$	530	30	1.2	graduation on front and back
7110-600	600mm/24"	$\pm 0.50\text{mm}$	630	30	1.2	graduation on front and back
7110-1000	1000mm/40"	$\pm 0.50\text{mm}$	1040	32	1.5	graduation on front and back
7110-1500	1500mm/60"	$\pm 1.00\text{mm}$	1550	38	1.8	graduation on front
7110-2000	2000mm/80"	$\pm 1.00\text{mm}$	2065	40	2.0	graduation on front

TAPER GAGE AND STEEL RULE SET

use the taper gage to measure diameter of hole

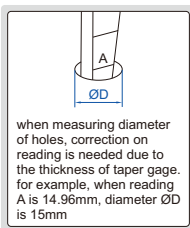

when measuring diameter of holes, correction on reading is needed due to the thickness of taper gage. for example, when reading A is 14.96mm, diameter ØD is 15mm

use the taper gage to measure slot width

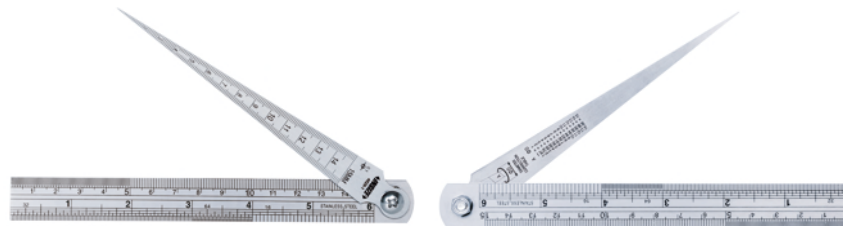
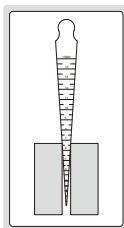

front

4829-1

back

- Diameter correction table on the taper gage back
- Made of stainless steel

Code	Tool	Range	Graduation	Accuracy
4829-1	taper gage	0.8-15mm	0.1mm	$\pm 0.05\text{mm}$
	steel rule	150mm/6"	1.0mm	$\pm 0.18\text{mm}$

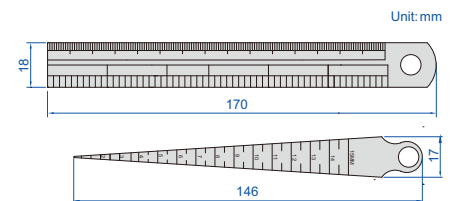

Unit: mm

ALUMINUM RULES

- Graduation: 1mm
- Made of aluminum, oxidized surface

Code	Range (L)	Accuracy	L1	W
7123-300	300mm	$\pm 0.5\text{mm}$	321mm	50mm
7123-600	600mm	$\pm 0.9\text{mm}$	624mm	50mm
7123-1000	1000mm	$\pm 0.9\text{mm}$	1024mm	50mm



7123-300

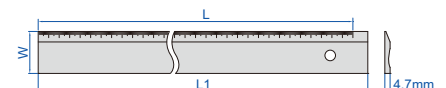

COMBINATION SQUARE SETS (CLOSE TYPE PROTRACTOR)

- Center head (made of cast iron): to locate center of cylinders with diameter (Ød): 30-100mm accuracy: ±0.15mm
- Protractor head (made of cast iron): set the blade at desired angle to an edge of a workpiece, and can be used to measure angles range: 0-180° accuracy: ±20min.
- Square head (made of cast iron): set the blade at 90° or 45° to an edge of a workpiece accuracy: ±8min for 90° square, ±10min for 45° square
- Blade (made of stainless steel): range: 300mm/12", graduation: 0.5mm and 1/32" on front face, 1mm and 1/64" on back face
- Optional accessory: rigid rule (code 7113)



2278-180

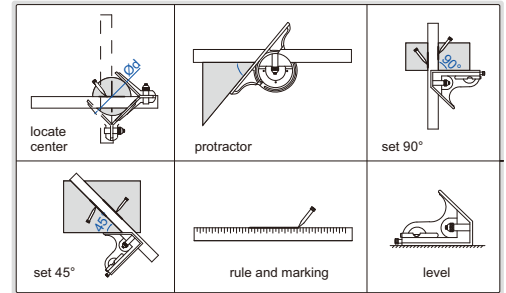
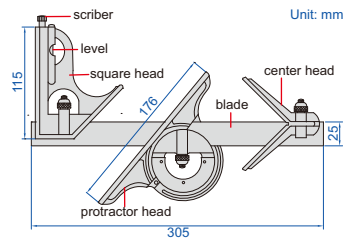

Code	Remark
2278-180	4-piece set

COMBINATION SQUARE (ECONOMIC TYPE)



2276-300

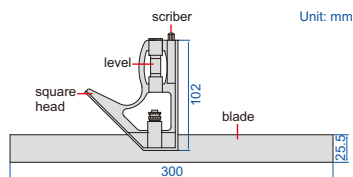

- Square head (made of zinc): set the blade at 90° or 45° to an edge of a workpiece accuracy: ±0.5°
- Blade (made of stainless steel): range: 300mm/12", graduation: 1mm and 1/32" on front face, 1mm and 1/16" on back face

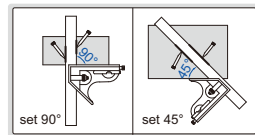

Code
2276-300

PLASTIC ANGLE SQUARE



2282-180

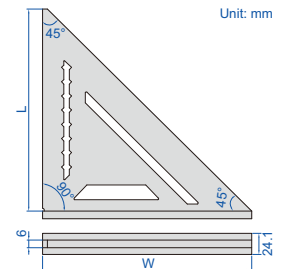

- Length range: 0-7", graduation: 1/8"
- Angel range: 0-90°, graduation: 1°

Code	Size (L×W)	Accuracy of angle
2282-180	180×185mm	±0.3°

T-BEVEL

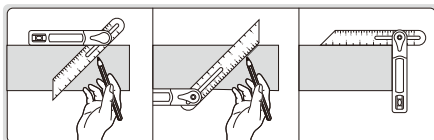

2281-360

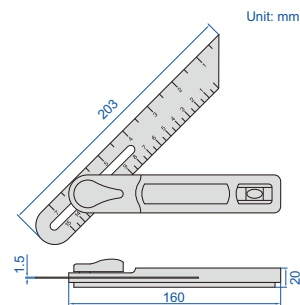

- Easy-to-read vial
- The blade can move and can be locked by the clamping screw
- Stainless steel blade
- Tough rubber handle
- Centimeter/inch graduations

blade can rotate 360°



Code	Angle mark	Accuracy of angle
2281-360	15°, 30°, 45°, 60°, 90°	±1°

MARKING GAGE

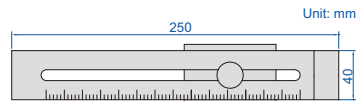

- Accuracy: $\pm 0.1\text{mm}$
- Made of carbon steel
- Satin chrome plated

7120-200A

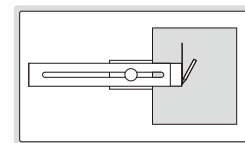

Code	Range	Graduation
7120-200A	0-200mm	0.1mm

T-SHAPE MARKING GAGE



1275-150B

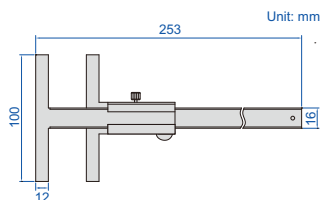

- Graduation: 0.02mm
- Made of stainless steel
- Satin chrome plated reading surface

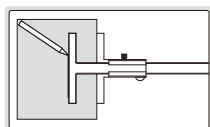

Code	Range	Accuracy
1275-150B	0-150mm	$\pm 0.04\text{mm}$

CENTER MARKING GAGE



7205-100

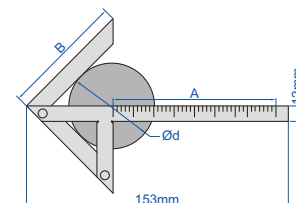

- Accuracy: $\pm 0.15\text{mm}$
- Diameter of shafts (Ød): 4-90mm
- Marking the center of round plates and shafts
- Made of stainless steel
- Satin chrome plated

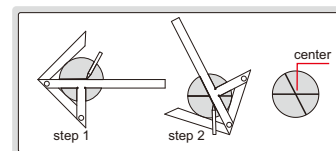

Code	Size (AxB)
7205-100	100x70mm

SCRIBER CALIPER



7202-200A

the position of scriber tip can be adjusted

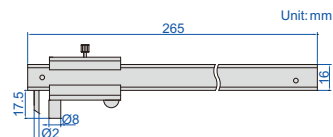

- Accuracy: $\pm 0.1\text{mm}$
- Graduation: 0.1mm, 1/128"
- Made of stainless steel
- Satin chrome plated reading surface
- Carbide scriber tip
- Optional accessory: carbide scriber tip (code SP-SCRIBER-7202)

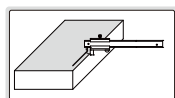

Code	Range
7202-200A	0-200mm/0-8"

SCRIBING CALIPER



7203-300A

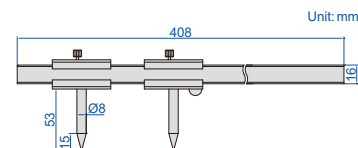
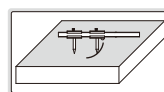

- Accuracy: $\pm 0.1\text{mm}$
- Graduation: 0.1mm
- Made of stainless steel
- Satin chrome plated reading surface
- Hardened scriber tips

Code	Range
7203-300A	51-300mm

DIGITAL SCRIBING CALIPER

- Non waterproof
- Resolution: 0.01mm/0.0005"
- The carbide-tipped jaws facilitate scribing on workpieces
- Buttons: on/off, zero, mm/inch
- Automatic power off, move the digital unit to turn on power
- Battery CR2032, data output
- Made of stainless steel

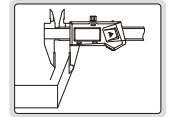
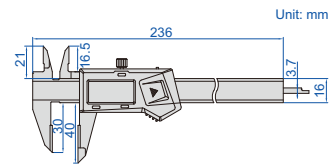

Code	Range	Accuracy
1166-150A	0-150mm/0-6"	±0.03mm

HEIGHT SCRIBER

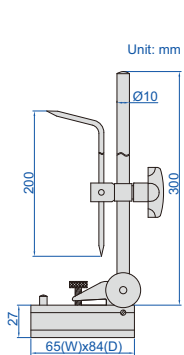

6990-300A

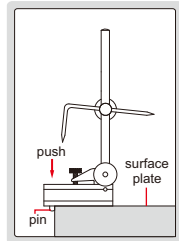
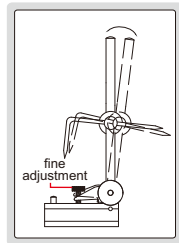

- Grooved bottom for cylinders
- Two pins to be set against the edge of surface plate

Code
6990-300A

SCRIBERS



7230
7231
7232

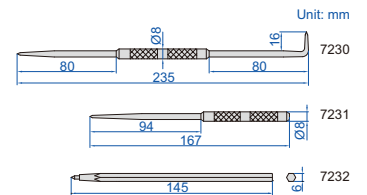

- 7230 and 7231 are nickel plated, 7232 is zinc-plated

Code	Tip
7230	hardened tips
7231	hardened tip
7232	carbide tip

**PRECISION SCREWDRIVER SET
CODE ISGF-0901**



ISGF-0901

- Includes:
4 pcs "-": 1.4mm, 2.0mm, 2.4mm, 3.0mm
2 pcs "+": 0#, 1#
- Rotating cap
- Material: CRV, hardness: HRC52-56



Code
ISGF-0901

4-PIECE MEASURING TOOL SET



5042

- Includes:
1) Digital caliper, range 0-150mm/0-6", resolution 0.01mm/0.0005" (code 1108-150)
2) Outside micrometer, range 0-25mm, graduation 0.01mm, (code 3202-25A)
3) 90° beveled edge square, 100x70mm, grade 0 (code 4790-1000)
4) Steel rule, 150mm/6" (code 7110-150)

Code
5042

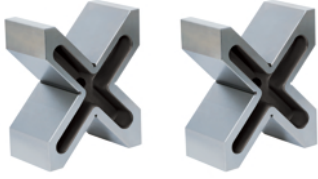

V-block Sets
Page 140



Magnetic V-blocks
Page 140

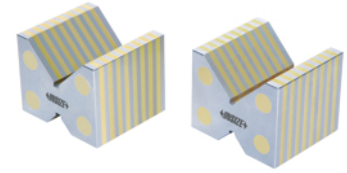

Magnetic Induction V-block Sets
Page 141

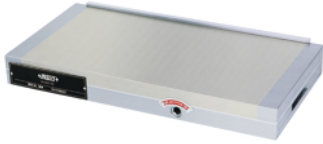

Permanent Magnetic Chucks
Page 141



Parallels Sets
Page 142



Parallel/Square Sets
Page 142

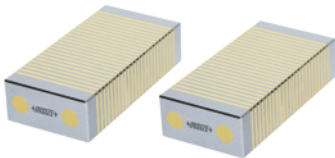

Magnetic Induction Parallel Sets
Page 142



Angle Plate Sets
Page 142



Sine Bars
Page 142



Precision Vises
Page 143



Stages
Page 143

V-BLOCK SETS

- For positioning cylindrical workpieces
- Two V-blocks per set
- Each V-block has four 90° V-grooves
- Cast iron, hardness HB170-240

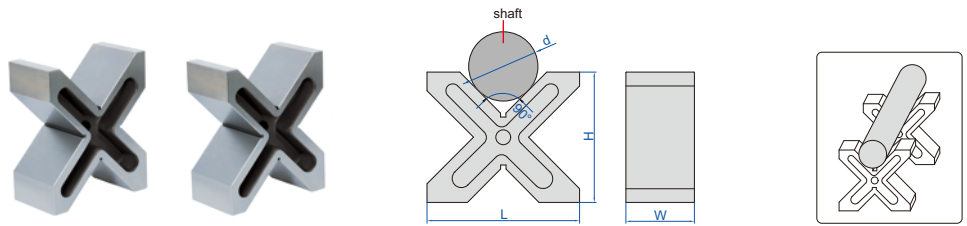

6805-2

Code	Size (L×H×W)	Range of shafts (Ød)	Parallelism of four V grooves to all sides	Height difference of a matched pair
6805-1	150×130×75mm	8-120mm	15µm	20µm
6805-2	200×170×90mm	12-180mm	15µm	20µm

MAGNETIC V-BLOCK (ECONOMIC TYPE)

ATTENTION: NOT HARDENED

ATTENTION: NOT SUITABLE FOR STEEL OR IRON SURFACES, OTHERWISE THE MAGNETIC FORCE WILL BE REDUCED

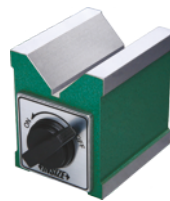
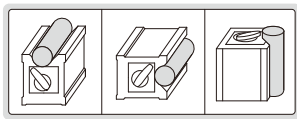

6890-702

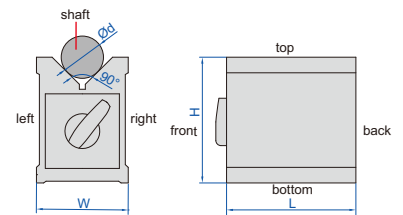

- Hold cylindrical workpieces for inspection and machining
- Supplied in single piece
- Not hardened
- Not suitable for steel or iron surfaces, otherwise the magnetic force will be reduced

Code	Size (LxWxH)	Range of shafts (Ød)	Magnetic force	Parallelism of V groove to top, bottom, left and right sides	Squareness of V groove to back side
6890-702	70x60x73mm	6-44mm	56kgf	10µm	10µm

MAGNETIC V-BLOCKS (ECONOMIC TYPE)

ATTENTION: NOT SUITABLE FOR STEEL OR IRON SURFACES, OTHERWISE THE MAGNETIC FORCE WILL BE REDUCED

ATTENTION: NOT HARDENED

- Parallelism of V grooves to top, bottom, left, right side: 10µm
- Squareness of V grooves to back side: 10µm
- Hold cylindrical workpieces for inspection and machining
- Not hardened
- V groove on the top for large shafts
- V groove on the bottom for small shafts
- Not suitable for steel or iron surfaces, otherwise the magnetic force will be reduced



6801-1201

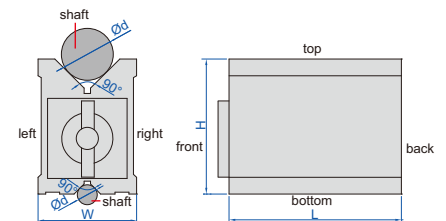

Code	Size (LxWxH)	Range of shafts (Ød)	Magnetic force
6801-1201	80x70x95mm	6-67mm	64kgf
6801-1202	100x70x95mm	6-67mm	80kgf
6801-1203	120x70x95mm	6-67mm	96kgf

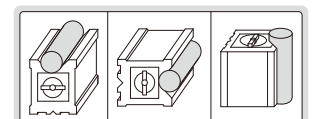

MAGNETIC INDUCTION V-BLOCK SET

ATTENTION: NOT HARDENED, DO NOT ROTATE WORKPIECES ON V-BLOCKS

- Hold cylindrical workpieces for inspection and machining
- To be used on magnetic chucks
- Two V-blocks per set
- V groove on the top for large shafts
- V groove on the bottom for small shafts
- Hardness HRB70
- Copper magnetic strips

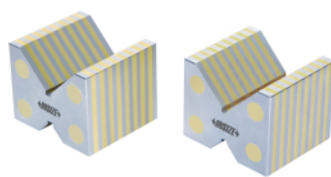

6878-1

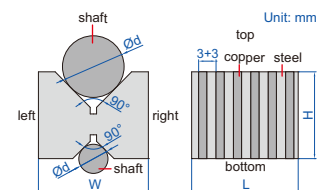

Code	Size (LxWxH)	Range of shafts ($\varnothing d$)	Pole pitch	Parallelism of both V grooves to top and bottom sides	Height difference of a matched pair
6878-1	52x58x46mm	6-56mm	3+3mm	10 μ m	10 μ m

MAGNETIC V-BLOCK SETS

ATTENTION: NOT HARDENED, DO NOT ROTATE WORKPIECES ON V-BLOCKS

- Hold cylindrical workpieces for inspection, not suitable for machining due to low magnetic force
- Two V-blocks per set
- Hardness HRB70

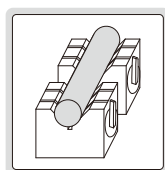

6891-1

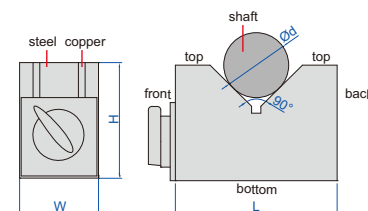

Code	Size (LxWxH)	Range of shafts ($\varnothing d$)	Magnetic force	Parallelism of V groove to bottom and back sides	Height difference of a matched pair
6891-1	70x40x50mm	6-46mm	15kgf	10 μ m	10 μ m
6891-3	150x50x100mm	6-125mm	21kgf	10 μ m	10 μ m

ATTENTION: LOW MAGNETIC FORCE

MAGNETIC SQUARE WITH V GROOVE

ATTENTION: NOT HARDENED, DO NOT ROTATE WORKPIECES ON V-BLOCKS

- Hold flat and cylindrical workpieces for inspection and machining
- Magnetic force on top, left, right and V grooves
- Parallelism and squareness of top, bottom, left, right and back: 20 μ m
- Parallelism and squareness of V grooves to top, bottom, left, right and back: 20 μ m



6539-100

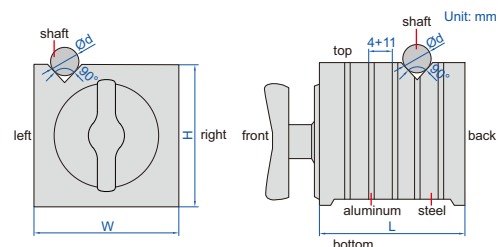

Code	Size (LxWxH)	Magnetic force of V grooves		Magnetic force of top, left and right sides		Range of shafts ($\varnothing d$)
		on granite surface plate	on cast iron plate	on granite surface plate	on cast iron plate	
6539-100	100x100x100mm	30kgf	25kgf	50kgf	30kgf	5-30mm

PERMANENT MAGNETIC CHUCK

ATTENTION: NOT HARDENED

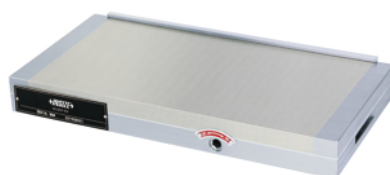

6537-400

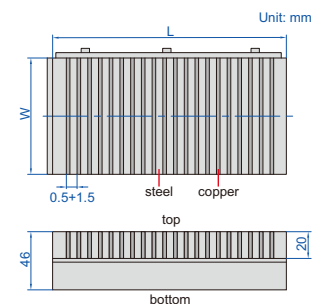

Code	Table size (LxW)	Magnetic force	Pole pitch	Parallelism of top to bottom
6537-400	400x200mm	8kgf/cm ²	0.5+1.5mm	0.02mm/300mm

PARALLEL SET

- Parallelism between top and bottom: 5µm
- Height difference of a matched pair: 5µm
- Hardened to HRC55-60
- Made of alloy tool steel



6533-144

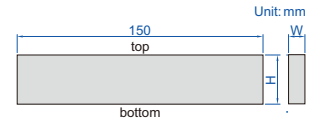

Code	Parallels per set	Thickness (W)	Height (H)
6533-144	14 pairs	10mm	14, 16, 18, 20, 22, 24, 26, 28, 30, 32, 35, 40, 45, 50mm

PARALLEL/SQUARE SET

- Size accuracy: 5µm
- Parallelism: 3µm
- Height difference of a matched pair: 5µm
- Pairs of matched blocks for positioning and set-up
- Screws and wrench are included
- Hardness HRC 55-62

screws and wrench are included



6531-25

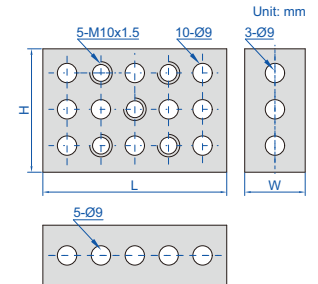

Code	Size (LxHxW)	Squareness
6531-25	75x50x25mm	5µm/25mm

MAGNETIC INDUCTION PARALLEL SET

ATTENTION: NOT HARDENED

- To be used on magnetic chucks
- Two parallels per set
- Hardness HRB70
- Copper magnetic strips

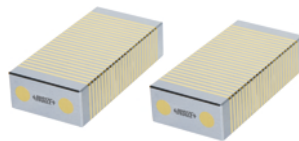

6879-1

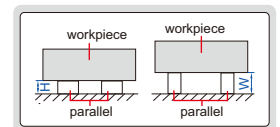
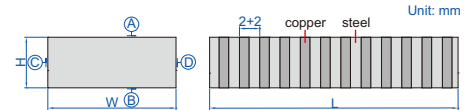

Code	Size (LxWxH)	Pole pitch	Parallelism between A and B	Parallelism between C and D	Height difference of a matched pair
6879-1	100x50x25mm	2+2mm	10µm	10µm	10µm

ANGLE PLATE SETS

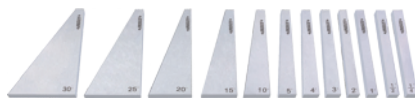

4006-12

- Accuracy: ±20 seconds
- For angle set-up in tooling, production and inspection
- Hardness HRC52

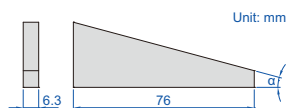

Code	Angle plates included	Angle α
4006-10	10 pcs	1°, 2°, 3°, 4°, 5°, 10°, 15°, 20°, 25°, 30°
4006-12	12 pcs	1/4°, 1/2°, 1°, 2°, 3°, 4°, 5°, 10°, 15°, 20°, 25°, 30°

SINE BAR

- Made of alloy tool steel



4158-100

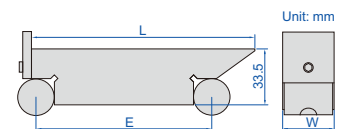
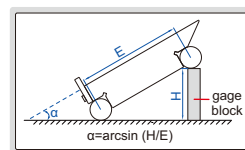

Code	Roller distance (E)	Table size (LxW)	Accuracy of α at 30°
4158-100	100mm	130x30mm	±5 seconds

PRECISION VISES

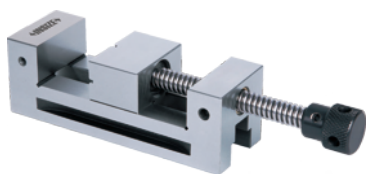

6520-73A

- Parallelism: 5µm/100mm
- Squareness: 5µm/100mm
- Made of alloy steel
- Hardness HRC58-60

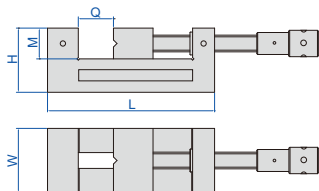

Code	Jaw opening (Q)	Jaw width (W)	L	H	M
6520-36	0-36mm	38mm	115mm	48mm	25mm
6520-67	0-67mm	50mm	150mm	50mm	25mm
6520-87	0-87mm	63mm	185mm	63mm	32mm
6520-102	0-102mm	73mm	205mm	70mm	35mm
6520-1021	0-102mm	80mm	215mm	80mm	40mm
6520-127	0-127mm	88mm	245mm	80mm	40mm
6520-1271	0-127mm	100mm	255mm	90mm	45mm
6520-162	0-162mm	125mm	295mm	100mm	50mm
6520-175	0-175mm	150mm	315mm	100mm	50mm
6520-200	0-200mm	200mm	350mm	110mm	55mm

QUICK MOVING PRECISION VISES

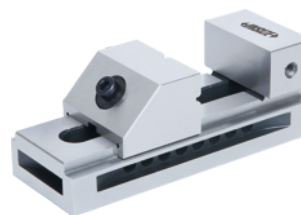

6526-80

- Parallelism: 5µm/100mm
- Squareness: 5µm/100mm
- Made of alloy steel
- Hardness HRC58-60

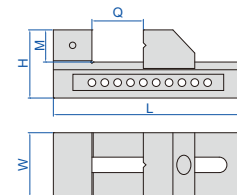

Code	Jaw opening (Q)	Jaw width (W)	L	H	M
6526-20	0-20mm	25mm	65mm	29mm	9.3mm
6526-40	0-40mm	38mm	100mm	48mm	23mm
6526-65	0-65mm	50mm	135mm	50mm	25mm
6526-85	0-85mm	63mm	170mm	63mm	32mm
6526-100	0-100mm	73mm	185mm	70mm	35mm
6526-1001	0-100mm	80mm	195mm	80mm	40mm
6526-125	0-125mm	88mm	230mm	80mm	40mm
6526-1251	0-125mm	100mm	240mm	90mm	45mm
6526-160	0-160mm	125mm	280mm	100mm	50mm
6526-175	0-175mm	150mm	300mm	100mm	50mm
6526-208	0-208mm	200mm	350mm	110mm	55mm

X-AXIS STAGE

- Cross roller guides, achieve high precision and smooth movement
- Stages made of aluminum alloy



6582-602

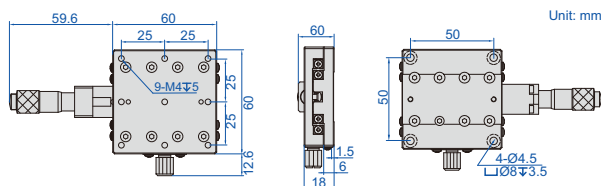

SPECIFICATION (micrometer in the middle)

Code	X-axis displacement	Parallelism of top to bottom surface	Micrometer graduation	Micrometer accuracy	Maximum load	Micrometer location	Stage size	Weight
6582-602	±6.5mm	0.03mm	0.01mm	0.01mm	49N (5kgf)	middle	60x60mm	0.24kg

XY-AXIS STAGE

- Cross roller guides, achieve high precision and smooth movement
- Stages made of aluminum alloy

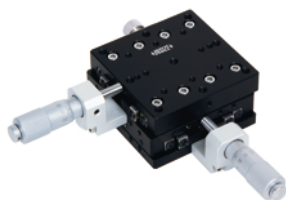

6584-602

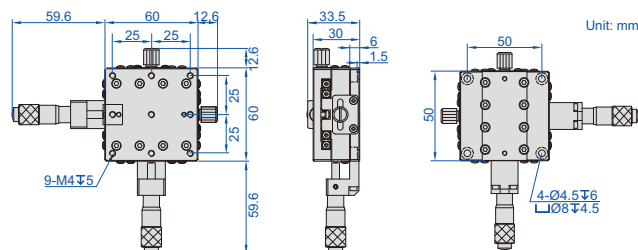

SPECIFICATION (micrometer in the middle)

Code	XY-axis displacement	Parallelism of top to bottom surface	Micrometer graduation	Micrometer accuracy	Maximum load	Micrometer location	Stage size	Weight
6584-602	±6.5mm	0.06mm	0.01mm	0.01mm	49N (5kgf)	middle	60x60mm	0.48kg



Centering Indicators
Page 145



Edge Finders
Page 145



3D Testers
Page 146



Edge Finders For EDM
Page 146



Infrared Transmission Probes For CNC Machine Tools
Page 147



Trigger-Type 3D Probes
Page 148



Zero Setters
Page 148

CENTERING INDICATOR

POPULAR MODEL



2385-3

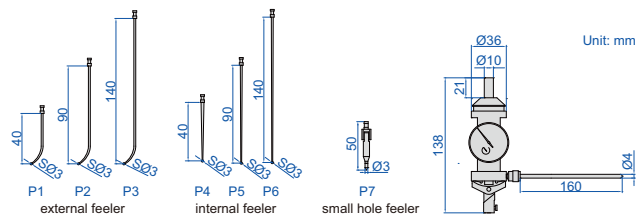

- Provides quick and accurate centering in boring and milling set-up
- Maximum speed is recommended not to exceed 800RPM

Code

2385-3

Feeler	Measuring diameter	Accuracy
P1	Ø0-60mm	0.015mm
P2	Ø0-160mm	0.02mm
P3	Ø0-250mm	0.03mm
P4	Ø3.2-80mm	0.015mm
P5	Ø3.2-180mm	0.02mm
P6	Ø3.2-280mm	0.03mm
P7	Ø0-2.8mm	0.015mm

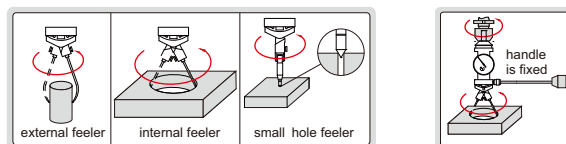

ELECTRONIC EDGE FINDER

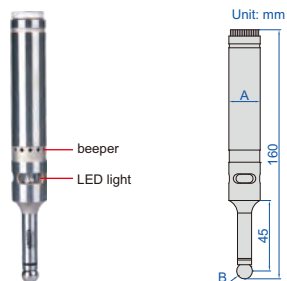
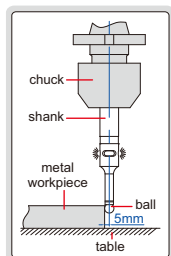

6566-3

- The shank is electrically conducted to the metal workpiece through the chuck and table, the LED lights up and the beeper sounds, when the ball touches the workpiece
- Not suitable for rotary use
- Hardened shank and contact ball
- Battery: 23A, 12Vx1 pc

Code	Shank (A)	Contact ball (B)	Accuracy	Beeper
6566-3	Ø20mm	SØ10mm	5µm	with

EDGE FINDERS

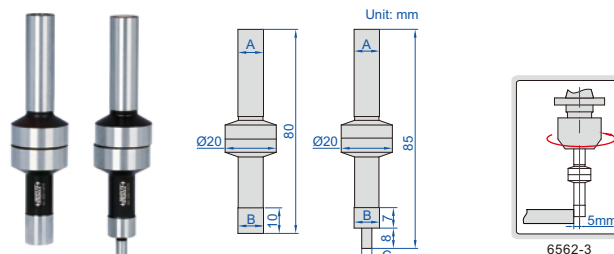

6562-3 6562-4

- Hardened shank and contact point
- Suitable for machine speed 400-600rpm

Code	Shank (A)	Contact point (B)	Contact point (C)	Accuracy
6562-3	Ø10mm	Ø10mm	—	5µm
6562-4	Ø10mm	Ø10mm	Ø4mm	5µm

EDGE FINDER

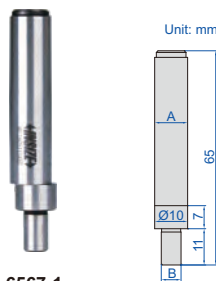
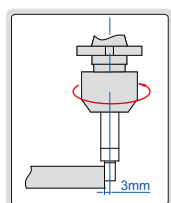

6567-1

- Hardened shank and contact point
- Suitable for machine speed 400-600rpm

Code	Shank (A)	Contact point (B)	Accuracy
6567-1	Ø10mm	Ø6mm	8µm

CERAMIC EDGE FINDER

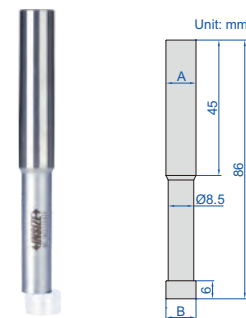
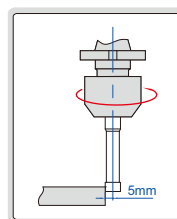

6568-1

- Ceramic contact point, non magnetic
- Suitable for machine speed 400-600rpm

Code	Shank (A)	Contact point (B)	Accuracy
6568-1	Ø10mm	Ø10mm	8µm

3D TESTER

INSIZE PLUS
MADE IN EUROPE

WHEN USING STANDARD PROBE, READING SHOWS MOVEMENT VALUE OF PROBE.
WHEN USING EXTENDED PROBE, READING DOES NOT SHOW MOVEMENT VALUE OF PROBE

IP67
WATERPROOF

SHOCK
PROOF

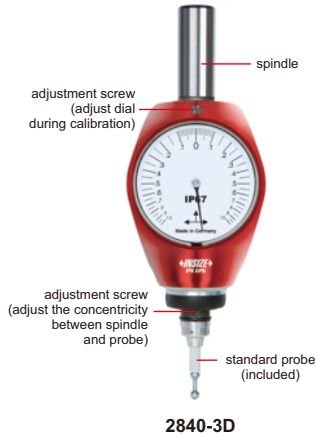
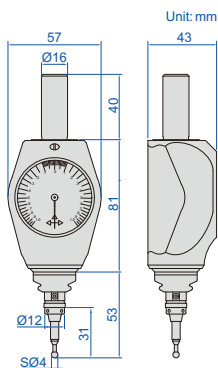

2840-3D

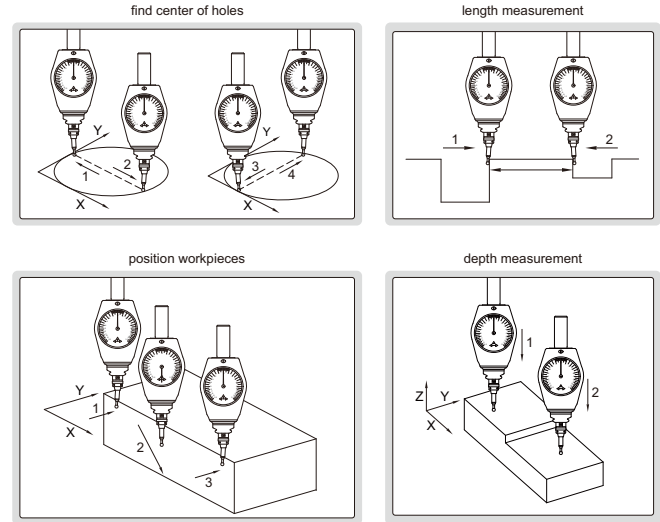

- Shockproof, IP67 dust/waterproof
- Mainly used for milling machines and CNC machine tools
 - determine coordinate point on workpieces
 - find center of holes
 - adjust and position workpieces
- Can be used to measure length and depth
- When using standard probe, reading shows movement value of probe, for example, if probe moves 0.05mm, reading changes 0.05mm (5 graduations).
When using extended probe, reading does not show movement value of probe
- Large working range on three axes (X, Y, Z), which avoids damage of probes due to collision by mistake

if the probe is pressed too much, the probe breaks at the breaking point, in order to prevent damage of the main body

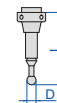
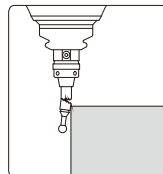

standard probe



extended probe

PROBE (optional)

Code	Description	L	D
2840-N1	standard probe	31mm	SØ4mm
2840-N2	extended probe	56.6mm	SØ6mm

EDGE FINDERS FOR EDM

CAN BE CUSTOM-MADE

- To locate workpieces
- Buzzer in EDM sounds when the ball touches the workpiece
- Tungsten steel ball, diameter accuracy: $\pm 0.003\text{mm}$
- Non magnetic stainless steel spindle
- Magnetic base



6558-52

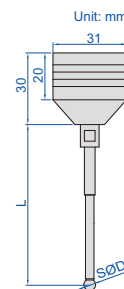

Code	Ball dia. (SØD)	Spindle length (L)	Measuring depth (H)	Spindle type
6558-11	SØ1mm	69mm	5mm	P4
6558-21	SØ2mm	49mm	6mm	P1
6558-22	SØ2mm	69mm	6mm	P4
6558-23	SØ2mm	119mm	8mm	P4
6558-31	SØ3mm	48mm	6mm	P1
6558-32	SØ3mm	68mm	7mm	P4
6558-33	SØ3mm	118mm	10mm	P4
6558-41	SØ4mm	48mm	37mm	P3
6558-42	SØ4mm	68mm	57mm	P2
6558-43	SØ4mm	118mm	16mm	P4
6558-44	SØ4mm	168mm	28mm	P7
6558-51	SØ5mm	47mm	36mm	P3
6558-52	SØ5mm	67mm	56mm	P2
6558-53	SØ5mm	117mm	106mm	P2

Code	Ball dia. (SØD)	Spindle length (L)	Measuring depth (H)	Spindle type
6558-54	SØ5mm	167mm	46mm	P6
6558-61	SØ6mm	47mm	35mm	P3
6558-62	SØ6mm	67mm	56mm	P3
6558-63	SØ6mm	87mm	76mm	P3
6558-64	SØ6mm	117mm	107mm	P2
6558-65	SØ6mm	167mm	51mm	P6
6558-81	SØ8mm	46mm	46mm	P5
6558-82	SØ8mm	66mm	54mm	P3
6558-83	SØ8mm	116mm	105mm	P3
6558-84	SØ8mm	166mm	51mm	P6
6558-101	SØ10mm	45mm	34mm	P3
6558-102	SØ10mm	65mm	53mm	P3
6558-103	SØ10mm	115mm	114mm	P5
6558-104	SØ10mm	165mm	53mm	P6

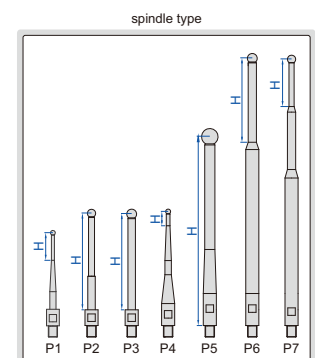

INFRARED TRANSMISSION PROBES FOR CNC MACHINE TOOLS

IP68
WATERPROOF



- On-machine measurement of all kinds of small and medium-sized machining centers, CNC boring, milling machines and five-axis CNC machine tools
- Automatically set the workpiece coordinate and machining reference point before CNC machining process
- Automatically measure dimension and position coordinate during CNC machining
- Measure dimension, shape and position after CNC machining is completed
- Four kinds of SSR signals such as probe status, error, low voltage and pulse are transmitted to CNC machine tools
- M code is used to control on or off of probes
- Infrared transmission, strong anti-interference
- Infrared transmission/reception range: 5m
- Supplied with automatic measurement software
- Optional accessory: styli

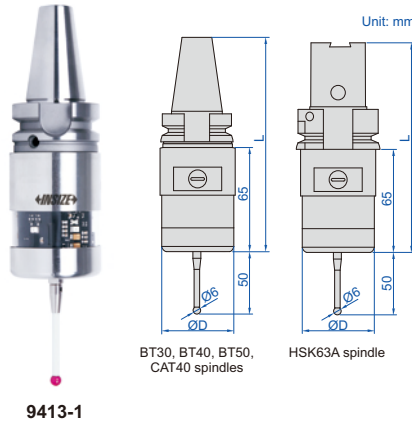

PROBE SPECIFICATION

Code	9413-1	9413-2	9413-3	9413-4	9413-5
Probe length (L)	140mm	166mm	216mm	168mm	136mm
Probe diameter (ØD)	48mm	48mm	48mm	48mm	48mm
Applicable spindle	BT30	BT40	BT50	CAT40	HSK63A
Trigger accuracy of styli in any direction	1µm				
Protection stroke triggered by styli in all directions	X and Y axis stroke: ±12.5°, Z axis stroke: 5mm				
Trigger force of styli in all directions	X and Y axis: 1-1.6N, Z axis: 5-10N				
Dust/waterproof	IP68				
Power supply	2×LS14250 lithium battery				

* SK and ISO spindle probes also can be customized



RECEIVER SPECIFICATION

Code	9413-A
Protection function	low battery voltage or probe transmitting signal all the time**
Applicable probe	code 9413-1, 9413-2, 9413-3, 9413-4, 9413-5
Cable length	8m
Dust/waterproof	IP68
Power supply	input voltage: 24V±10% (DC), load current: 50mA

** When battery voltage is low or probe is in wrong state, receiver sends a signal to CNC machine to stop working

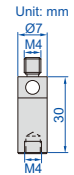

EXTENSION ROD (OPTIONAL)

Code	Material
9410-R1	ceramic

STYLI (OPTIONAL)

(mm)

Code	L1	L2	Ød	Material of rod***	Material of ball
9410-P1	18	13	4	stainless steel	ruby
9410-P2	18	13.5	5	stainless steel	ruby
9410-P3	18.5	13	3	stainless steel	ruby
9410-P4	19	8	2	carbide	ruby
9410-P5	19.5	4	1	carbide	ruby
9410-P6	50	40	2	carbide	ruby
9410-P7	50	34	5	ceramic	ruby
9410-P8	100	86	6	ceramic	ruby
9410-P9	40	30	4	ceramic	ruby
9410-P10	50	36	6	ceramic	ruby

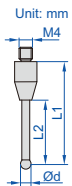

*** For stainless steel or carbide rods, it is recommended to use extension rods to protect spindles in case of break

AUTOMATIC MEASUREMENT SOFTWARE (INCLUDED)

- Stylus automatic calibration
- Protection of stylus during probe movement (avoid collision)

- Groove and boss measurement

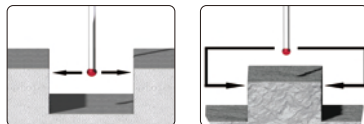

- X or Y single-surface measurement



- 4th axis measurement
- Angle on X and Y plane measurement
- Three points measurement of arc

- Bore and axis measurement

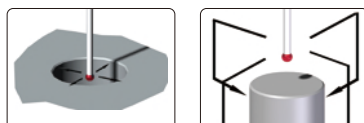

- Internal and external corner measurement

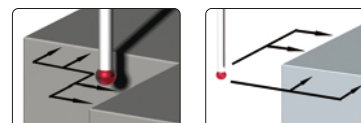

- Measure the distance between two holes

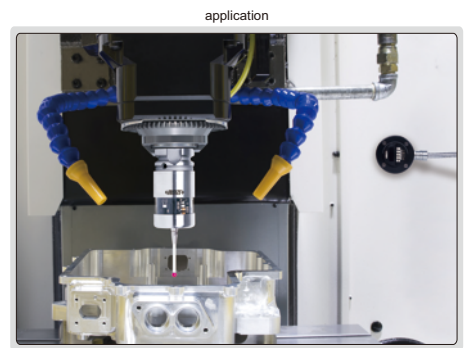
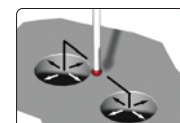

TRIGGER-TYPE 3D PROBE (AUDIBLE AND VISUAL ALARM) CODE 9410

IP67
WATERPROOF

- Suitable for all kinds of machining centers, CNC boring machines, milling machines, drilling and tapping centers
- Suitable for workpiece detection of various solid materials
- Manually set the workpiece coordinates and machining reference points before CNC machining process
- In the process of CNC machining, manually detect and control key dimensions and position coordinates and their accuracy
- Detect the accuracy of the key size, shape and position of the workpiece after completion of CNC machining
- Standard Ø20mm shank diameter, held by CNC
- LED indicator and buzzer indicate the trigger state of the probe
- Using lithium battery charging technology, no need to replace the battery
- The battery (5% utilization rate per shift) can be used continuously for 90 days
- Type-C interface
- Optional accessory: styli and extension bar

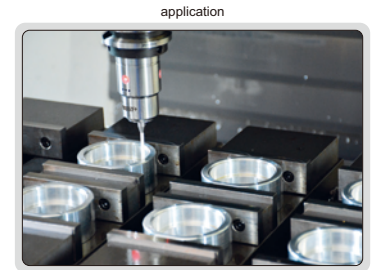
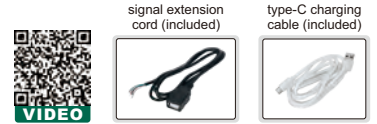
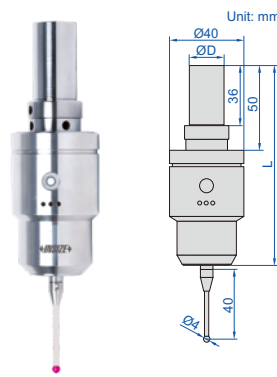

SPECIFICATION

Probe length (L)	115.5mm
Shank diameter (ØD)	20mm
Trigger direction	±X, ±Y, +Z
Directional trigger protection stroke	X-Y: ±12°, Z: +5mm
Arbitrary one-way repeated trigger accuracy	≤1µm
Trigger force in X-Y direction (with standard styli)	0.3-0.6N
Trigger force in Z direction	4N
Dust/waterproof	IP67
Type-C charging cable	1.5m
Signal extension cord (provide signals to CNC)	1m

STYLI (OPTIONAL)

Code	L1	L2	Ød	Material of rod *	Material of ball
9410-P1	18	13	4	stainless steel	ruby
9410-P2	18	13.5	5	stainless steel	ruby
9410-P3	18.5	13	3	stainless steel	ruby
9410-P4	19	8	2	carbide	ruby
9410-P5	19.5	4	1	carbide	ruby
9410-P6	50	40	2	carbide	ruby
9410-P7	50	34	5	ceramic	ruby
9410-P8	100	86	6	ceramic	ruby
9410-P9	40	30	4	ceramic	ruby
9410-P10	50	36	6	ceramic	ruby

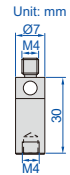
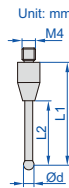

EXTENSION ROD (OPTIONAL)

Code	Material
9410-R1	ceramic

* For stainless steel or carbide rods, it is recommended to use extension rods to protect spindles in case of break

DIGITAL ZERO SETTER

IP65
WATERPROOF

- Repeatability: 2µm
- Resolution: 0.001mm/0.00005"
- IP65 dust/waterproof
- Buttons: on/off, mm/inch, zero
- CR2032 battery
- Automatic power off
- Magnetic base
- Automatic backlight at zero

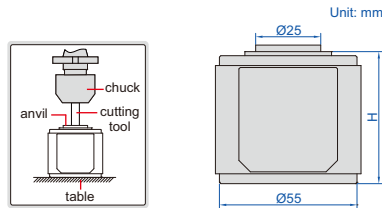

6557-50

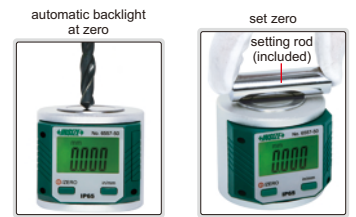

Code	Height (H)	Anvil stroke	Accuracy *	Test force
6557-50	50mm	2.5mm	±10µm/0.0004"	10N (at 50mm)

* The accuracy is ensured within Ø10mm of the center

ZERO SETTER



6556-50

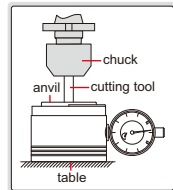

Code	Height (H)	Graduation	Accuracy	Test force
6556-50	50mm	0.01mm	±0.01mm	10N (at 50mm)

ZERO SETTER

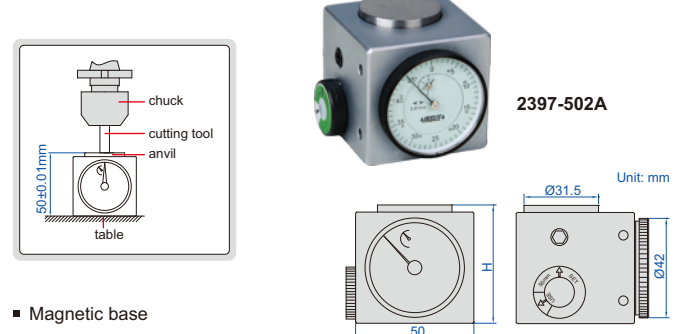

2397-502A

- Magnetic base

Code	Height (H)	Graduation	Accuracy	Test force
2397-502A	50mm	0.01mm	±0.01mm	9N (at 50mm)



Digital Levels And Slope Meters
Page 150-152



Frame Levels
Page 152



Block Levels
Page 153



Levels
Page 153-155



Cross-line Laser Levels
Page 156



Self-leveling Rotary Lasers
Page 156

DIGITAL LEVEL CODE ISE-2DT

DATA OUTPUT

- Color LCD, touch panel
- X-Y axis measurement
- Set the tolerance and the display is shown in different colors



- To show the incline with line or bubble

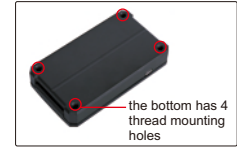

SPECIFICATION

Measuring range	±30°
Resolution	0.1°, 0.01°, 0.1mm/m
Accuracy	±0.03° (range 0~3°) ±0.05° (range >3°)
Power supply	rechargeable battery
Dimension	115×66×25mm
Weight	224g

STANDARD DELIVERY

Main unit	1 pc
USB cable	1 pc

OPTIONAL ACCESSORY

Software	ISE-2DT-SOFTWARE
----------	------------------

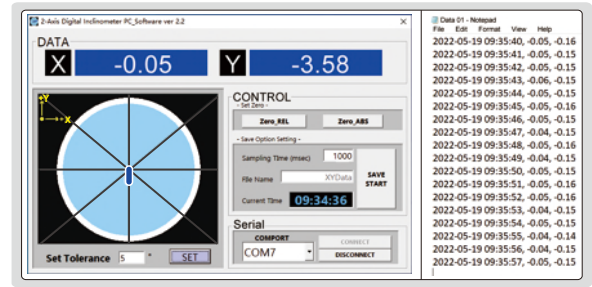

PC software (optional), send data to txt

DUAL AXIS DIGITAL LEVEL AND GYRO ANGLE METER

DATA OUTPUT

ATTENTION: HARD PLASTIC CASE

BACKLIGHT

AUDIBLE ALARM WHEN OUT OF LIMIT

DISPLAY FLIPS OVER WHEN THE BOTTOM FACES UP

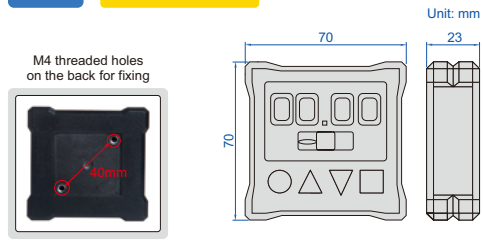

2199-1

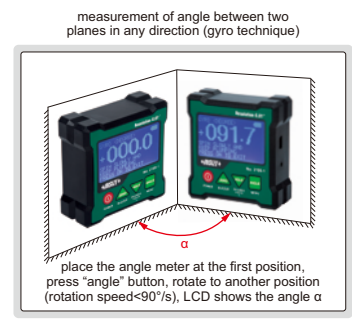
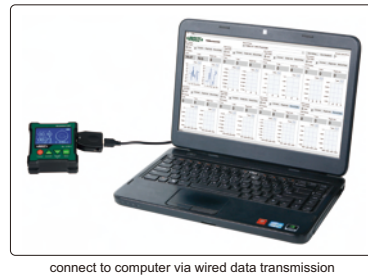
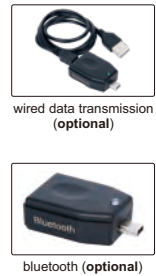
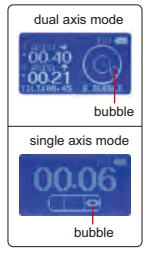
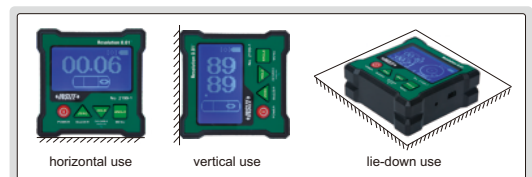

- Single axis/double axis level and slope meter, gyro technique can measure the angle between two planes in any direction
- Hard plastic case, with V-shaped grooves, four magnetic sides
- Display flips over when the bottom faces up
- Audible alarm when out of limit
- Buttons: POWER, ZERO, HOLD, display unit (°, mm/m, %), MENU
- Rechargeable Li-ion battery 3.7V, operation time is 40 hours
- Automatic power off in 30 minutes
- Data output
- Android and iPhone APP are included
- Optional accessory: wired data transmission (code 2199-A01), bluetooth (code 2199-A02), transmission distance is 10 meters (under the condition of no obstruction and no electromagnetic interference)

Code	Range	Resolution	Accuracy
2199-1	single axis level: 4x90° dual axis level: ±40°	0.01°	at 0° and 20°: ±0.08° at 20° and 70°: ±0.15° at 70° and 90°: ±0.08°
	gyro angle meter: 360°	0.1°	±0.5°

Android and iPhone APP (included), can choose real-time display (continuous transmission) or single transmission

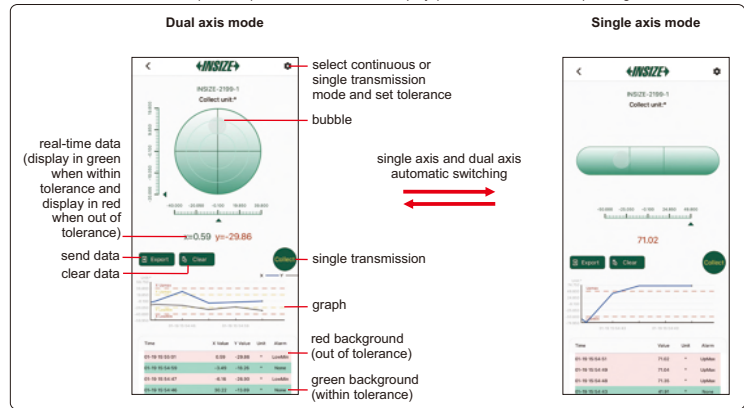

DIGITAL LEVEL AND SLOPE METER

BACKLIGHT

BUZZER ALARM
AT 0° AND 90°

WORKING TEMPERATURE
-5°C ~ 50°C

IP67
WATERPROOF

ABSOLUTE
LEVEL

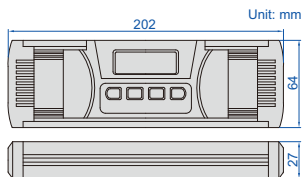

2175-360

- IP67 dust/waterproof
- Used as level and slope meter
- Aluminum frame, shock absorbing rubber end caps
- Magnetic bottom with V-groove for shafts
- The sea level is permanently set inside the chip, zero setting is not needed when batteries are replaced
- Buttons: ON/OFF, backlight/buzzer alarm, absolute and incremental measurement, unit (mm/m, %, °), HOLD (keep the reading)
- Three AAA batteries, automatic power off

Code	Range	Resolution	Accuracy
2175-360	0-360° (90°x4)	0.05° (=0.873mm/m)	at 0°: ±0.05°; at others: ±0.1°

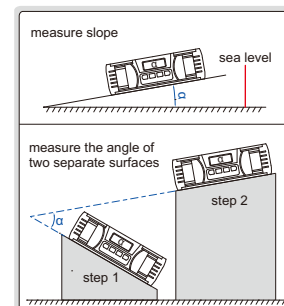

DIGITAL LEVEL AND SLOPE METER



2173-360

- Resolution: 0.1° (=1.745mm/m)
- Aluminum frame
- Used as level and slope meter
- Magnetic bottom with V-groove for shafts
- Zero setting can be made on any plain surfaces
- Buttons: ON/OFF, ZERO, HOLD (keep the reading)
- CR2032 battery
- Automatic power off

Code	Range	Accuracy
2173-360	0-360°(90°x4)	at 0° and 90°: ±0.1°, at others: ±0.2°

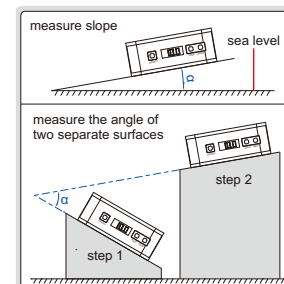
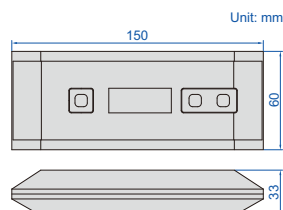

DIGITAL LEVEL AND SLOPE METER

BACKLIGHT

BUZZER ALARM
AT 0° AND 90°

WORKING TEMPERATURE
-5°C ~ 50°C

IP54
WATERPROOF

ABSOLUTE
LEVEL



2179-360

- Resolution: 0.05° (=0.873mm/m)
- IP54 dust/waterproof
- Used as level and slope meter
- Aluminum frame
- Magnetic bottom with V-groove for shafts
- The sea level is permanently set inside the chip, zero setting is not needed when battery is replaced
- Buttons: ON/OFF, absolute and incremental measurement, keep the reading, buzzer alarm, unit (mm/m, %, in/ft), conversion, backlight
- Two AAA batteries, automatic power off

Code	Range	Accuracy
2179-360	0-360°(90°x4)	at 0° and 90°: ±0.1°, at others: ±0.2°

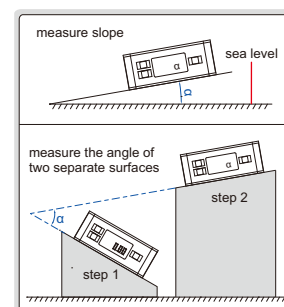
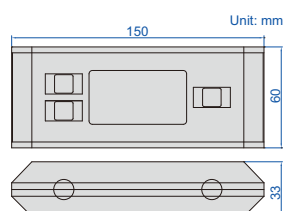

BLUETOOTH DIGITAL LEVEL AND SLOPE METER

WORKING TEMPERATURE
-5°C~50°C

MAGNETIC
BOTTOM

DISPLAY FLIPS OVER WHEN
THE BOTTOM FACES UP



BACKLIGHT

ABSOLUTE
LEVEL

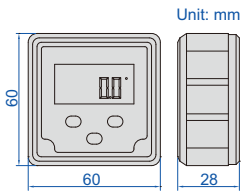

2198-2

- Used as level and slope meter
- Aluminum frame
- Magnetic bottom
- The display flips over when the bottom faces up
- The backlight is on automatically when in use, and automatically off in 15 seconds after use
- The sea level is permanently set inside the chip, zero setting is not needed when battery is replaced
- Buttons: ON/OFF, ZERO, HOLD, absolute and incremental measurement
- Built-in bluetooth, transmission distance is 15 meters (under the condition of no obstruction and no electromagnetic interference). Android and iPhone APP are included
- One AAA battery, automatic power off in 5 minutes

Code	Range	Resolution	Accuracy
2198-2	4x90°	0.1° (=1.745mm/m)	at 0° and 90°: ±0.1°; at others: ±0.2°

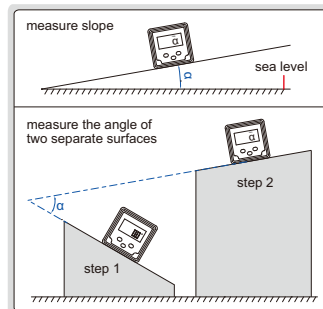

Android and iPhone APP (included), can choose real-time display (continuous transmission) or single transmission

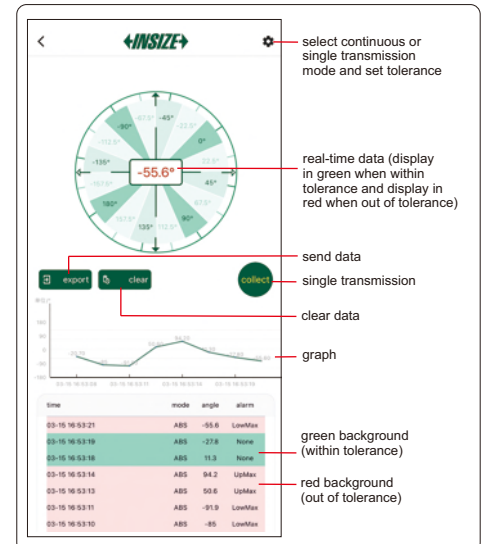

DIGITAL LEVEL AND SLOPE METER

MAGNETIC
BOTTOM

ABSOLUTE
LEVEL

WORKING TEMPERATURE
-5°C~50°C

BACKLIGHT

DISPLAY FLIPS OVER WHEN
THE BOTTOM FACES UP

POPULAR
MODEL

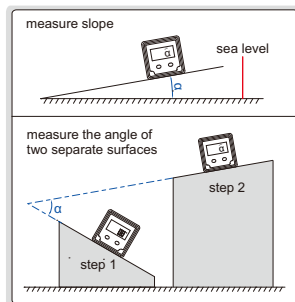

2170-1

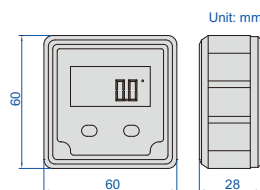

- Used as level and slope meter
- Aluminum frame, magnetic bottom
- The display flips over when the bottom faces up
- The backlight is on automatically when in use, and automatically off in 15 seconds after use
- The sea level is permanently set inside the chip, zero setting is not needed when battery is replaced
- Buttons: ON/OFF, ZERO, absolute and incremental measurement
- One AAA battery, automatic power off in 5 minutes

Code	Range	Resolution	Accuracy
2170-1	4x90°	0.1° (=1.745mm/m)	at 0° and 90°: ±0.1°, at others: ±0.2°



FRAME LEVELS



4902-200

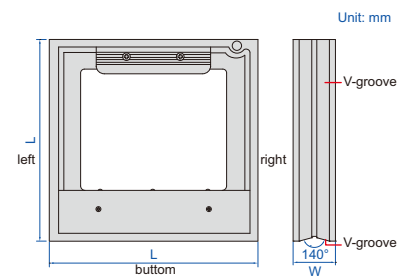

- V-groove on bottom and left for shafts (shafts dia. 15~68mm)
- With transverse vial

Code	Sensitivity	Size (LxL)	W
4902-150	0.02mm/m (=0.001°)	150x150mm	40mm
4902-200	0.02mm/m (=0.001°)	200x200mm	40mm
4902-300	0.02mm/m (=0.001°)	300x300mm	45mm
4902-C150	0.05mm/m (=0.0029°)	150x150mm	40mm
4902-C200	0.05mm/m (=0.0029°)	200x200mm	40mm
4902-C300	0.05mm/m (=0.0029°)	300x300mm	45mm

BLOCK LEVELS

POPULAR MODEL



- V-groove on bottom for shafts (shafts dia. 15~68mm)
- With transverse vial



4903-200A

Code	Sensitivity	Length (L)
4903-150A	0.02mm/m (=0.001°)	150mm
4903-200A	0.02mm/m (=0.001°)	200mm
4903-300A	0.02mm/m (=0.001°)	300mm
4903-C150	0.05mm/m (=0.0029°)	150mm
4903-C200	0.05mm/m (=0.0029°)	200mm
4903-C300	0.05mm/m (=0.0029°)	300mm

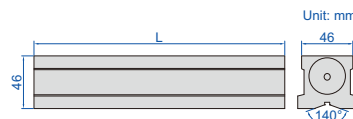

DIGITAL LEVELS AND SLOPE METERS

WORKING TEMPERATURE
0°C ~ 50°C

BACKLIGHT

ABSOLUTE LEVEL

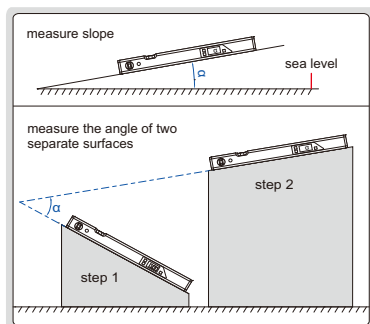

both angle and slope are displayed



4910-400



4910-600

- With transverse and longitudinal vials
- Used as level and slope meter
- Aluminum frame, magnetic bottom
- The sea level is permanently set inside the chip, zero setting is not needed when batteries are replaced
- Buttons: ON/OFF, absolute and incremental measurement, keep the reading, buzzer alarm (not for 4910-400), unit (mm/m, %, in/ft), conversion (not for 4910-400), backlight
- The display flips over when the bottom faces up
- Two AAA batteries, automatic power off

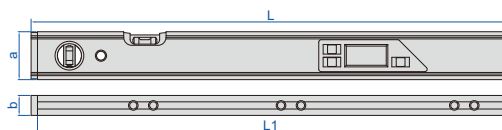

Code	Range	Resolution	Accuracy	Remark	L	L1	a	b
4910-400	0~360° (90°×4)	angle: 0.1°; slope: 1mm/m	±0.2°	both angle and slope are displayed	416mm	400mm	50mm	21mm
4910-600	0~360° (90°×4)	at 0° and 90°: 0.05° (=0.8725mm/m); at others: 0.1° (=1.745mm/m)	at 0° and 90°: ±0.1°; at others: ±0.2°	at 0° and 90° buzzer alarms	600mm	585mm	60mm	25mm

HANDY LEVEL

MAGNETIC BASE

LIFETIME WARRANTY VIALS

- Shockproof vials
- Magnetic base
- Shock absorbing rubber end caps
- Working temperature: -15°C~55°C

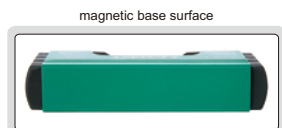

4912-100

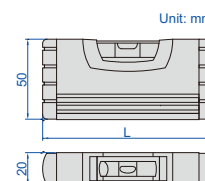

Code	Size (L)	Accuracy
4912-100	100mm	0.5mm/m

HANDY LEVELS

LIFETIME WARRANTY VIALS

MAGNETIC BASE

- Shockproof horizontal and vertical vials
- Magnetic base
- Shock absorbing rubber end caps
- Working temperature: -15°C~55°C



4922-100



4922-150

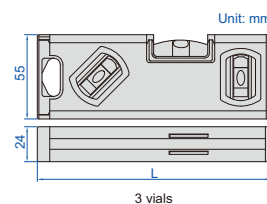
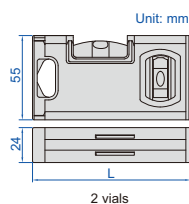

Code	Size (L)	Accuracy	Number of vials
4922-100	100mm	0.5mm/m	2
4922-150	150mm	0.5mm/m	3
4922-200	200mm	0.5mm/m	3

CASTING ALUMINUM LEVEL

MAGNETIC BASE

LIFETIME WARRANTY VIALS



4913-250

packaging



magnetic bottom surface (milled)



- Shockproof horizontal and vertical vials
- Magnetic base
- Working temperature: -15°C~55°C
- Cast aluminum body

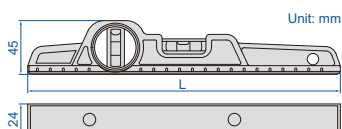

Code	Size (L)	Accuracy
4913-250	250mm	0.5mm/m

ALUMINUM LEVEL

MAGNETIC BASE

LIFETIME WARRANTY VIALS



4921-230

- Shockproof horizontal and vertical vials
- Magnetic base
- Shock absorbing rubber end caps
- Working temperature: -15°C~55°C

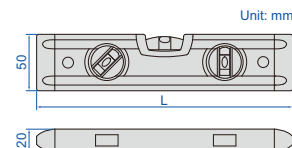

Code	Size (L)	Accuracy
4921-230	230mm	0.5mm/m

ALUMINUM LEVELS

LIFETIME WARRANTY VIALS



4911-600

- Top and bottom working surfaces
- Shock-proof and UV-proof vials
- Die casting aluminum alloy frame
- Zero position of horizontal vial can be set
- One graduation of horizontal vial is 2% slope
- Working temperature: -15°C~55°C

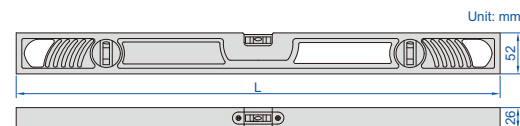

bottom surface (non-magnetic, milled)

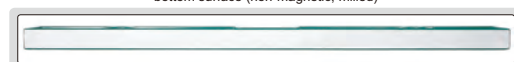

Code	Length (L)	Accuracy
4911-600	600mm	0.5mm/m
4911-800	800mm	0.5mm/m

ALUMINUM LEVELS

LIFETIME WARRANTY VIALS

MAGNETIC BASE



4914-600



magnetic bottom surface (milled)



4914-2000

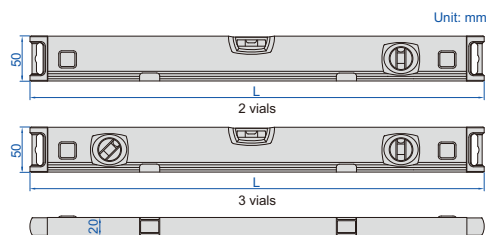

- Shockproof horizontal and vertical vials
- Magnetic base
- Shock absorbing rubber end caps
- Working temperature: -15°C~55°C

Code	Size (L)	Accuracy	Number of vials
4914-300	300mm	0.5mm/m	2
4914-600	600mm	0.5mm/m	2
4914-1000	1000mm	0.5mm/m	2
4914-2000	2000mm	0.5mm/m	3

ALUMINUM LEVELS (BASIC TYPE)

LIFETIME WARRANTY VIALS

MAGNETIC BASE



4918-300

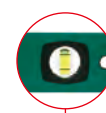

4918-2000

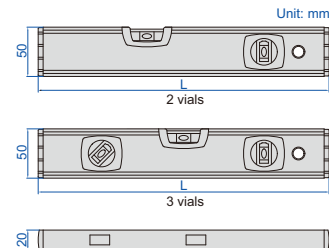

- Accuracy: 1mm/m
- Shock-proof and UV-proof vials
- Magnetic base
- Shock absorbing rubber end caps
- Working temperature: -15°C~55°C

magnetic bottom surface



Code	Size (L)	Number of vials
4918-300	300mm	2
4918-600	600mm	2
4918-800	800mm	2
4918-1000	1000mm	2
4918-1200	1200mm	2
4918-2000	2000mm	3

ALUMINUM LEVELS (WITH ROTARY VIAL)

LIFETIME WARRANTY VIALS

- Shockproof and UV-proof vials
- Horizontal, vertical and rotary vials
- Rotary vial, range: 0°~360°, graduation: 5°
- Plumb window
- Shock absorbing rubber end caps
- Working temperature: -15°C~55°C

Code	Length (L)	Accuracy
4920-400	400mm	0.5mm/m
4920-600	600mm	0.5mm/m
4920-800	800mm	0.5mm/m
4920-900	900mm	0.5mm/m
4920-1000	1000mm	0.5mm/m
4920-1200	1200mm	0.5mm/m



4920-600

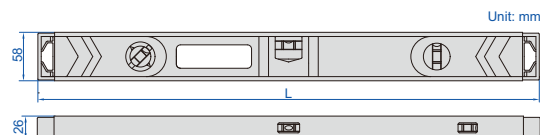

ALUMINUM LEVEL WITH RULER

LIFETIME WARRANTY VIALS

- Shockproof horizontal and vertical vials
- Non-magnetic milled base
- Shock absorbing rubber end caps
- Range of ruler: 0-60cm, graduation: 1mm
- Working temperature: -15°C~55°C

Code	Size (L)	Accuracy
4923-600	600mm	0.5mm/m



4923-600

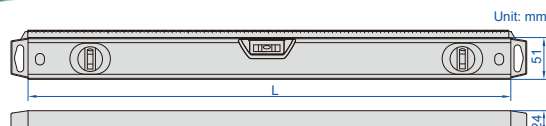

CROSS-LINE LASER LEVEL CODE 4917-30



IP54
WATERPROOF

AUDIBLE AND VISUAL
WARNING WHEN OUT OF $\pm 3^\circ$

- Red horizontal and vertical cross laser lines
- Self-leveling within $\pm 3^\circ$, self-leveling time within 4s, audible and visual warning when out of $\pm 3^\circ$
- Folding legs for angle and height adjustment
- Outdoor use with the detector (code: 4917-DETECTOR)



folding legs for angle and height adjustment

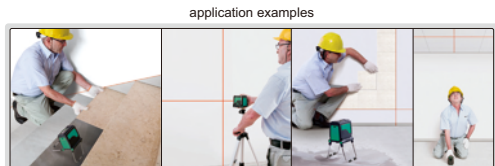
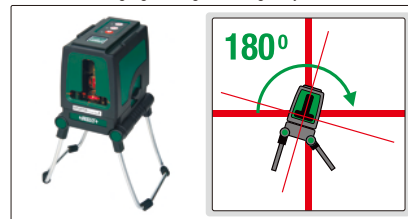

application examples

SPECIFICATION

Laser line width	2 \pm 0.5mm (within 5m)
Laser type	red laser, 630~660nm, class II, <1mW
Beam angle	120 \pm 0.5 $^\circ$
Self-leveling range	$\pm 3^\circ$
Working distance	indoor: 30m, outdoor: 50m with detector (optional)
Accuracy	0.2mm/m
Operation temperature	-10~40 $^\circ$ C
Power supply	3 \times AA batteries, for 3 hours working
Dimension	100 \times 82 \times 104mm
Weight	620g

STANDARD DELIVERY

Main unit	1 pc
1/4" to 5/8" tripod adaptor	1 pc
Battery (AA)	3 pcs



outdoor detector (optional)

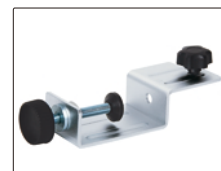

stand (included with outdoor detector)

OPTIONAL ACCESSORY

Outdoor detector	4917-DETECTOR
------------------	---------------

OUTDOOR DETECTOR (OPTIONAL)

Detecting distance	horizontal 1~50m, vertical 1~30m
Detecting accuracy*	high accuracy ± 1.5 mm, low accuracy ± 2.5 mm
Power supply	9V battery
Dimension	168 \times 58 \times 30mm
Weight	140g (battery included)

* Use high accuracy detection mode within 15m, use low accuracy detection mode over 15m

SELF-LEVELING ROTARY LASER CODE GRL-L340



IP65
WATERPROOF

INDICATOR FLASHING
WHEN OUT OF $\pm 5^\circ$



tripod (included)



horizontal leveling

vertical leveling

working with detector

SPECIFICATION

Working range	indoor 50m, outdoor 300m (with detector)	
Self leveling range	$\pm 5^\circ$	
Horizontal/vertical beam accuracy	± 0.1 mm/m	
Main laser type	green laser, 520~540nm, class 2, <1mW	
Auxiliary laser type	red laser, 645~655nm, class 2, <1mW	
Rotating speed	0/60/120/300/600rpm	
Scanning range	0/10/45/90/180/360 $^\circ$	
Setting slope	X axis: $\pm 5^\circ$, Y axis: $\pm 5^\circ$	
Operation temperature	-20~50 $^\circ$ C	
Maximum remote control distance	20m	
Power supply	remote controller	2 \times 1.5V AAA batteries
	main unit	NI-MH batteries or 4 \times 1.5V C batteries
	detector	1 \times 9V battery
Dimension	210 \times 210 \times 213mm	
Weight	2.5kg	

- Applicable fields: construction, decoration, pipeline and equipment installation
- Green laser beam rotates 360 $^\circ$ horizontally or vertically
- Self-leveling range $\pm 5^\circ$ on both X and Y planes
- Alarm when inclination is out of $\pm 5^\circ$
- $\pm 5^\circ$ leveling range for manual mode on both X and Y planes
- 5 variable speeds 0-600rpm
- 6 scan modes
- Plumb up and plumb down dots
- Remote control for long distance
- Power supply: AC or DC

STANDARD DELIVERY

Main unit (including NI-MH batteries)	1 pc
C battery and bracket	1 set
Detector	1 pc
Remote controller	1 pc
Beam finder glasses	1 pc
Laser target	1 pc
Power adapter	1 pc
AAA battery	2 pcs
9V battery	1 pc
Tripod	1 pc



remote controller (included)



detector (included)



bracket for C battery (included)



beam finder glasses (included)



Linear Scales
Page 158-159



Digital Readouts
Page 158-159



Scales
Page 160



Air Gage Displays
Page 161



Laser Scan Micrometers
Page 161



Tool Presetters
Page 162

LINEAR SCALES (TTL SIGNAL)



ISL-B5-300

Series ISL-B5

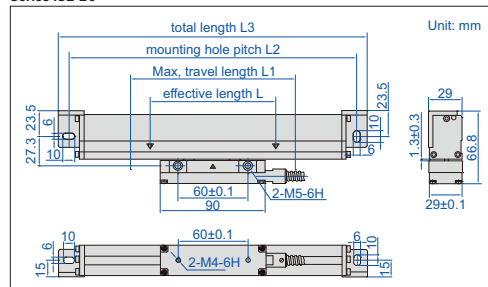

- Optical TTL (Through-The-Lens) detection. These optical TTL linear scales use an transistor logic to transmit and record high-resolution distance measurements. They are the most accurate type of encoder and are paired with ISL-DR2/DR3 and ISL-LCD7 (digital readout)

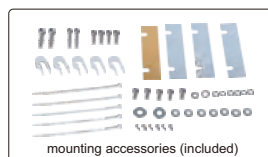
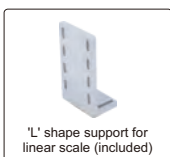
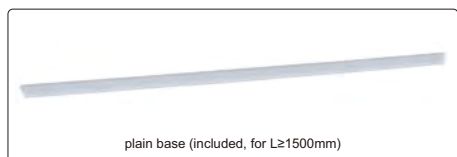

SPECIFICATION

Code	Series ISL-B5	
L1 (mm)	L+30 (L≤900)	L+50 (L>900)
L2 (mm)	L+136 (L≤900)	L+156 (L>900)
L3 (mm)	L+154 (L≤900)	L+174 (L>900)
Resolution	5μm	
Max. response speed	60m/min	
Scale grating pitch	20μm	
Scale reference point pitch	50mm	
Accuracy	±(5+5L/1000)μm L is the effective length in mm	
Cable length	3.5m (L: 50-950mm), 5m (L: 1000-1500mm), 10m (L: 1600-2000mm)	
Output signal	TTL	
Socket	9PD	
Power supply	5±0.5V	

Effective length (L)	Code
	thick type
100mm	ISL-B5-100
300mm	ISL-B5-300
500mm	ISL-B5-500
1000mm	ISL-B5-1000

STANDARD DELIVERY

Main unit	1 pc
'L' shape support	1 pc
Anti-dust cover	1 pc
Plain base	1 pc (for L≥1500mm)
Mounting accessories	1 package

DIGITAL READOUTS

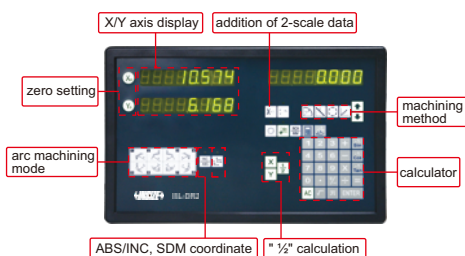

ISL-DR2

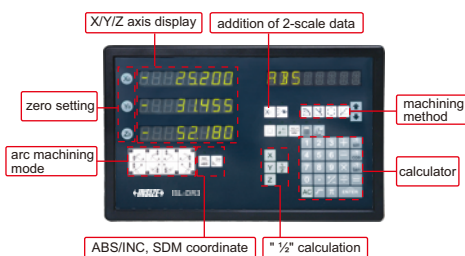

ISL-DR3



- For ISL-B5 series linear scales

SPECIFICATION

Code	ISL-DR2	ISL-DR3
Application	two-axis	three-axis
Scale input ports	2	3
Resolution	0.05μm, 0.1μm, 0.2μm, 0.5μm, 1μm, 2μm, 5μm, 10μm, 20μm, 50μm	
Functions	addition of 2-scale data, linearity error compensation, smoothing, RS232C interface unit, BCD code out, zero setting, preset, resolution setting, counting direction setting, inch/mm conversion, ABS/INC conversion, expansion/contraction coefficient setting, "1/2" calculation, detecting RI, bolt-hole circle machining, ramp circle machining	
Power supply	110/220V, 50/60Hz	
Dimension	295x185x45mm	
Weight	1.45kg	

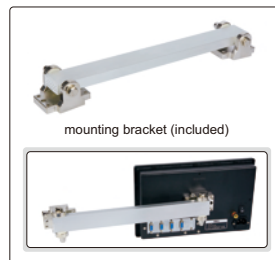

STANDARD DELIVERY

Main unit	1 pc
Mounting bracket	1 pc
Ground cable	1 pc
RS232C cable	1 pc
Software flash disk for RS232C	1 pc

LINEAR SCALE AND READOUT SET FOR LATHE CODE ISL-SET1

software flash disk
(included)

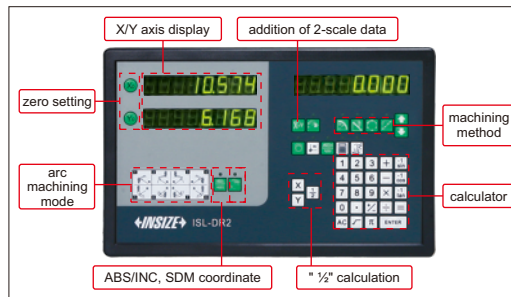

- Optical TTL (Through-The-Lens) detection. These optical TTL linear scales use an transistor logic to transmit and record high-resolution distance measurements

READOUT SPECIFICATION

Application	two-axis
Scale input ports	2
Resolution	1 μ m
Functions	addition of 2-scale data, linearity error compensation, smoothing, RS232C interface unit, BCD code out, zero setting, preset, resolution setting, counting direction setting, inch/mm conversion, ABS/INC conversion, expansion/contraction coefficient setting, "1/2" calculation, detecting RI, bolt-hole circle machining, ramp circle machining
Power supply	110/220V, 50/60Hz
Dimension	295×185×45mm
Weight	1.45kg

LINEAR SCALE SPECIFICATION

X-axis	200mm
Y-axis	1000mm
Max. response speed	50m/min
Scale grating pitch	20 μ m
Scale reference point pitch	50mm
Accuracy	$\pm(5+5L/1000)\mu$ m L is the effective length in mm
Cable length	200mm scale: 3.5m, 1000mm scale: 5m

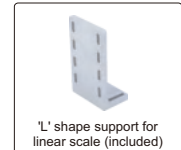

STANDARD DELIVERY

Readout box	1 pc
200mm linear scale	1 pc
1000mm linear scale	1 pc
Mounting bracket for readout	1 pc
Ground cable for readout	1 pc
RS232C cable for readout	1 pc
Software flash disk for RS232C of readout	1 pc
'L' shape support for linear scale	1 pc
Anti-dust cover for linear scale	1 pc
Mounting accessories for linear scale	1 package

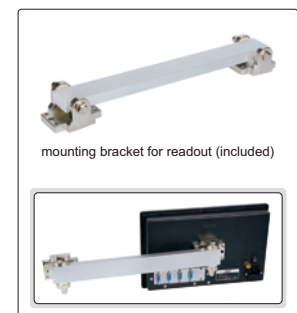

DIGITAL HORIZONTAL SCALES

DATA OUTPUT



7101-300A



7101-400A

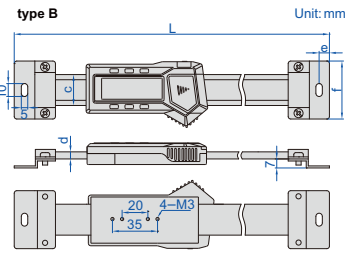
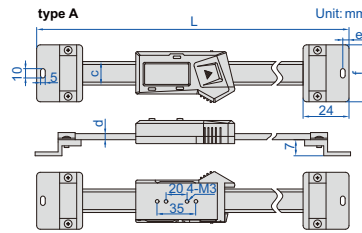

- Non waterproof
- Resolution: 0.01mm/0.0005"
- Buttons type A: on/off, zero, mm/inch, type B: on/off, zero, mm/inch, ABS, data preset
- Automatic power off, move the digital unit to turn on power
- Battery CR2032
- Data output
- Made of stainless steel
- Supplied with bracket to be mounted on the back

example of application

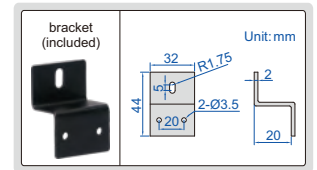
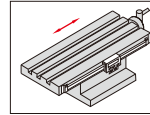

Code	Range	Type	Accuracy	L	c	d	e	f	Data output cable (optional)
7101-100A	100mm	A	±0.02mm	215mm	16mm	4mm	6mm	36mm	7315-21 receiver is needed, 7302-21, 7305-21
7101-150A	150mm	A	±0.03mm	265mm	16mm	4mm	6mm	36mm	7315-21 receiver is needed, 7302-21, 7305-21
7101-200A	200mm	A	±0.03mm	315mm	16mm	4mm	6mm	36mm	7315-21 receiver is needed, 7302-21, 7305-21
7101-300A	300mm	A	±0.04mm	445mm	16mm	4mm	6mm	36mm	7315-21 receiver is needed, 7302-21, 7305-21
7101-400A	400mm	B	±0.05mm	590mm	24mm	5.5mm	8mm	45mm	7315-22 receiver is needed, 7302-22, 7305-22
7101-500A	500mm	B	±0.05mm	690mm	24mm	5.5mm	8mm	45mm	7315-22 receiver is needed, 7302-22, 7305-22
7101-600A	600mm	B	±0.08mm	790mm	24mm	5.5mm	8mm	45mm	7315-22 receiver is needed, 7302-22, 7305-22
7101-800A	800mm	B	±0.10mm	990mm	24mm	5.5mm	8mm	45mm	7315-22 receiver is needed, 7302-22, 7305-22
7101-1000A	1000mm	B	±0.10mm	1240mm	31mm	10.5mm	10mm	60mm	7315-22 receiver is needed, 7302-22, 7305-22

DIGITAL VERTICAL SCALES

DATA OUTPUT

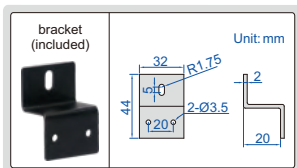

- Non waterproof
- Resolution: 0.01mm/0.0005"
- Buttons: on/off, zero, mm/inch, ABS/INC, data hold, TOL, set
- Battery LR44, data output
- Made of stainless steel
- Supplied with bracket to be mounted on the back
- Optional accessory: wireless transmitter (code 7315-1150 receiver is needed), data output cable (code 7302-SPC7, keyboard format), data output cable (code 7305-1150, serial port format)

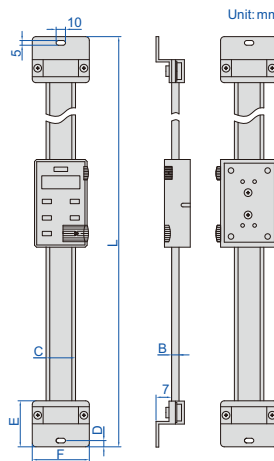

example of application

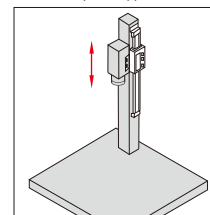

7102-300

Code	Range	Accuracy	B	C	D	E	F	L
7102-100	100mm/4"	±0.02mm	4mm	20mm	6mm	24mm	40mm	245mm
7102-150	150mm/6"	±0.03mm	4mm	20mm	6mm	24mm	40mm	296mm
7102-200	200mm/8"	±0.03mm	4mm	20mm	6mm	24mm	40mm	345mm
7102-300	300mm/12"	±0.04mm	4mm	20mm	6mm	24mm	40mm	445mm
7102-400	400mm/16"	±0.05mm	4mm	20mm	6mm	24mm	40mm	545mm
7102-500	500mm/20"	±0.05mm	5.5mm	24mm	8mm	32mm	45mm	685mm
7102-600	600mm/24"	±0.08mm	5.5mm	24mm	8mm	32mm	45mm	785mm
7102-800	800mm/32"	±0.10mm	5.5mm	24mm	8mm	32mm	45mm	985mm
7102-1000	1000mm/40"	±0.10mm	10.5mm	31mm	9.5mm	40mm	60mm	1245mm

AIR GAGE DISPLAY CODE 9408-QD100



air filter (optional)



pressure regulating valve (optional)



foot switch (optional)



RS485 cable (optional)

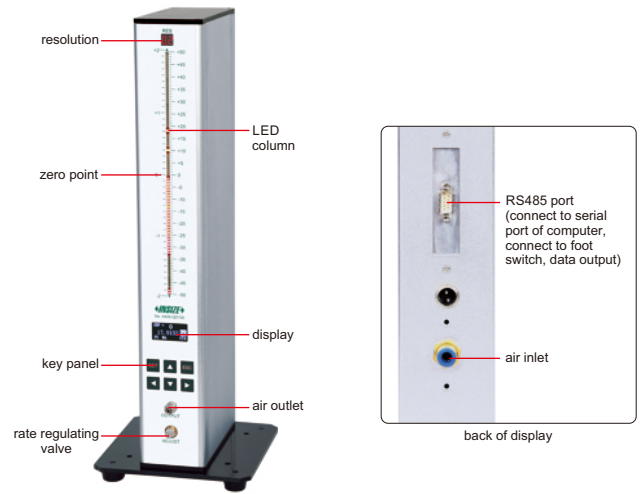
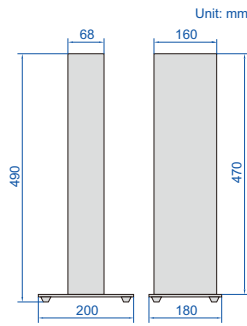

SPECIFICATION

LED quantity	101 pcs			
LED color	red, orange, green			
LED height	254mm			
Range, resolution and accuracy	range	resolution		accuracy
		LED	display	
	10μm	0.1μm	0.1μm	0.2μm
	20μm	0.2μm	0.1μm	0.4μm
	50μm	0.5μm	0.1μm	1μm
100μm	1μm	0.1μm	2μm	
Unit	mm, μm			
Air supply	dry and clean, 0.4~0.8MPa			
Data interface	RS485			
Operation temperature	-20~45°C			
Power supply	110~220V, 50/60Hz			
Dimension (L×W×H)	200×180×490mm			
Weight	4.5kg			

- Can store 10 measuring programs, and the program can be switched quickly
- Data storage function, support manual and automatic storing, 1500 groups data can be stored



STANDARD DELIVERY

Main unit	1 pc
-----------	------

OPTIONAL ACCESSORY

Air filter	9401-FILTER-A
Pressure regulating valve	9404-PRV
RS485 cable	9408-CB
Foot switch	9408-FS
Data output cable (keyboard format)	7302-9408

LASER SCAN MICROMETER CODE LDM-030

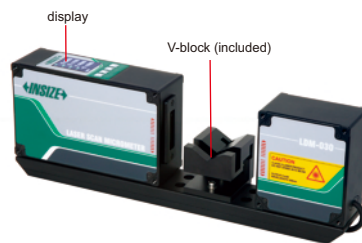
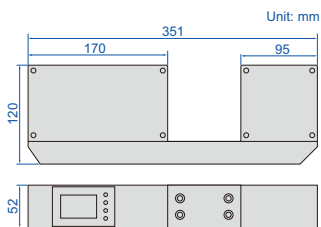

calibration gage (optional)

- Measure outer diameter, ellipticity, run-out, maximum diameter of tools, etc.
- Can be used for transparent or non transparent workpieces
- Tolerance measurement
- Online or offline measurement
- Connected with computer, PLC, control box

SPECIFICATION

Measuring range	0.1~30mm
Resolution	0.01/0.1/1/10/100μm selectable
25°C accuracy	±(0.5+10%D)μm, D is measuring diameter in mm
Repeatability	±(0.3+5%D)μm, D is measuring diameter in mm
Laser wave length	650nm
Measuring speed	800~3200times/s (adjustable)
Operation temperature	0~50°C
Operation humidity	35~85RH without condensation
Output	dual channel RS485
Alarm output	24V, 1A
Power supply	DC24V, 2A
Dimension (L×W×H)	351×52×120mm
Weight	5kg



connect to control box (optional)

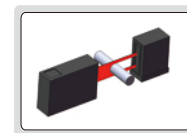

measure external diameter



two-axis measurement

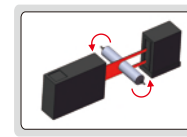

measure ellipticity and run-out

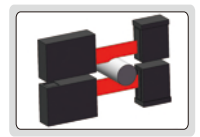

large size measurement

STANDARD DELIVERY

Main unit	1 pc
V-block	1 pc
AC/DC adapter	1 pc
RS485 cable	1 pc

OPTIONAL ACCESSORY

Calibration gage	custom made
Control box	custom made

TOOL PRESETTER (BASIC TYPE) CODE TLP-300H



- Absolute linear scales, zero setting is not needed after power on and off

SPECIFICATION

Maximum tool diameter (X axis)	Ø300mm
Height measuring range	60~300mm
Repeatability	0.005mm
Measuring accuracy	0.02mm
Linear scale resolution	0.005mm
Dial indicator graduation	0.01mm
Spindle holder	BT50
Power supply	110/220V, 50/60HZ
Dimension (L×W×H)	600x365x690mm
Weight	68kg



standard rod (included)



BT50/BT40 converter (optional)



BT50/BT30 converter (optional)

STANDARD DELIVERY

Main unit	1 pc
BT50 spindle holder	1 pc
Standard rod	1 pc
Dial indicator	2 pcs
Wrench	1 set
Anti-dust cover	1 pc

OPTIONAL ACCESSORY

BT50/BT30 converter	TLP-300H-C1
BT50/BT40 converter	TLP-300H-C2



Digital Ultrasonic Flaw Detectors
Page 164



Portable Magnetic Powder Flaw Detectors
Page 165



Rechargeable UV Flaw Detection Lights
Page 165

DIGITAL ULTRASONIC FLAW DETECTOR CODE UFD-T680

- The all-aluminum metal shell is strong and durable, and the electromagnetic shielding performance is very good
- Tempered glass panel, extremely hard, wear-resistant and scratch-resistant
- Full-digital multi-color high resolution (640×480 pixels) TFT LCD display
- 4 operation interface styles can be selected according to the environment
- Real-time screenshots of all pages and flaw detection reports, and save them as BMP pictures to U disk
- Export the flaw detection report as a PDF file
- Unique Fn multifunction key design
- There is no limit of the number and duration of video recording through U disk
- Memory of 500 channel files to store calibration setups and probe parameter
- Memory of 1000 wave report files to store A-Scan wave and settings
- Two fully independent gates offer a range of measurement options for signal height or distance using peak triggering
- Can choose to set the incoming wave alarm or lost wave alarm, accompanied by LED light display
- Selectable frequency ranges (automatically set by the instrument) to match probe for optimum performance
- The unique automatic gain adjustment and gain scanning function make flaw detection fast and accurate



FUNCTIONS

Flaw detection standard	built-in common flaw detection standards, direct call, convenient and fast
Auto calibration	automatic calibration of probe zero offset, probe angle (K value) and material velocity
Peak hold	compare frozen peak waveforms to live A-Scans to easily interpret test result
Flaw locating	live display sound-path, projection (surface distance), depth, amplitude
Flaw discrimination	automatic flaw sizing using AVG or DAC, speeds reporting of defect acceptance or rejection
Flaw sizing	the equivalent dB value of defects or equivalent size of defects are displayed in real time
Curved surface correction	used for flaw detection of curved workpiece, it can display the circumferential position of defects in real time
DAC/AVG	the curve is automatically generated, and the sampling points can be compensated and corrected. The curve automatically floats with the gain, automatically expands with the detection distance, and automatically moves with the delay time. It can display the AVG curve of any aperture
AWS D1.1	choosing this standard can reduce manual calculations and improve detection efficiency
Weld diagram	support V type, T type, L type and other weld types, acoustic path navigation real-time display, weld and defect location real-time display, scaling, easy to locate defects
Automatic rating	select different AWS standards, automatically calculate the rating of defects and display
Crack height	the crack height is measured and calculated automatically by the diffracted wave at the end
Gate magnify	spreading of the gate range over the entire screen width
Continuous record	video recording and playback
Echo coding	display 1~9 echo display area in different colors, used to analyze the defect position
Scan freeze	display freeze holds waveform and test distance data
Peak mark	capture and mark the peak in real time
B scan	intuitively display the defect shape of the workpiece and the detection result is more intuitive

SPECIFICATION

Measuring range	0~15000mm
Working frequency	0.2~20MHz
Material velocity	100~20000m/s
Repetition frequency	20~2000Hz
Dynamic range	≥36dB
Vertical linearity	≤1.5%
Horizontal linearity	≤0.1%
Resolving power	>42dB
Sensitivity leavings	>65dB
Suppression	0~80%
Noise	≤10%
Probe selection	single crystal probe, dual crystal probe, penetrating probe, climbing probe
Pulse energy	100V, 200V, 250V, 300V, 350V, 400V, 450V, 500V (selectable)
Pulse width	30ns-510ns
Probe damping	50Ω, 150Ω, 250Ω, 500Ω (selectable)
Rectification	positive half wave, negative half wave, full wave, RF
Gates	two independent gates controllable over entire sweep range
Interface	USB 2.0
Operation temperature	-10~50°C
Relative humidity	20~95%RH
Power	built-in rechargeable battery
Size	263×170×61mm
Weight	1.92kg



VIDEO



angle-beam probe (included)



straight-beam probe (included)



USB disk (included)



couplant (included)

STANDARD DELIVERY

Main unit	1 pc
Single-element straight probe UFD-T60	1 pc
Single-element angle probe UFD-T61	1 pc
USB cable	1 pc
Couplant	1 bottle
Probe connecting cable	1 pc
USB disk	1 pc
Power adapter	1 pc

SPECIFICATION OF PROBE

Code	Frequency	Size	Probe type	Transducer sensor angle
UFD-T60 (included)	2.5MHz	Ø20mm	single-element straight probe	90°
UFD-T61 (included)	4.0MHz	8x9mm	single-element angle probe	60°
UFD-T62 (optional)	5.0MHz	Ø10mm	dual-element straight probe	90°
UFD-T63 (optional)	5.0MHz	Ø10mm	single-element straight probe	90°
UFD-T64 (optional)	4.0MHz	8x9mm	single-element angle probe	45°
UFD-T65 (optional)	4.0MHz	8x9mm	single-element angle probe	70°

Note: Other types of the probes are available

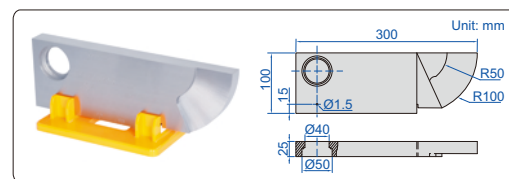

calibration block (optional)

OPTIONAL ACCESSORY

Calibration block	UFD-CSK1
--------------------------	-----------------

PORTABLE MAGNETIC POWDER FLAW DETECTORS



MPI-P110

- Conformity to standards JB/T7411-2012 ASTM E1444-05 ASTM E709 EN10228-1:1999 ISO 9934 ASTM E3024
- Multiple power supply modes available

SPECIFICATION

Code	MPI-P110	MPI-P220	MPI-P330
Magnetic field strength	>2KA/m		
Sensitivity	15/50 engraved groove clearly displayed on A1 standard sensitivity test piece		
Illumination	—	white light ≥2320Lux	UV lamp ≥5220μW/cm ²
Duty cycle	>50% maximum excitation time 90 seconds		>30%
Lifting power	AC	≥4.5kg (44N)	
	DC	≥18.1kg (177N)	
Magnetic pole spacing	0-230mm		
Magnetic pole size	22×22mm		
Power supply	AC220V, 50Hz (DC battery pack or AC battery pack are optional)		
Operation temperature	-10~40°C		
Relative humidity	<80% (no condensation)		
Dimension (L×W×H)	235×50×195mm		
Weight	2.3kg		



DC battery pack 4400mAh (optional)



AC battery pack 6600mAh (optional)



A1 standard sensitivity test piece (optional)



45N lifting force test block (optional)



177N lifting force test block (optional)



bag (optional)



magnetic pole slope angle A (optional)



magnetic pole slope angle B (optional)

OPTIONAL ACCESSORY

DC battery pack 4400mAh	MPI-PDC440
AC battery pack 6600mAh	MPI-PAC660
A1 standard sensitivity test piece	MPI-PA1
45N lifting force test block	MPI-P45N
177N lifting force test block	MPI-P177N
Magnetic pole slope angle A	MPI-PMA
Magnetic pole slope angle B	MPI-PMB
Bag	MPI-PBG

STANDARD DELIVERY

Main unit	1 pc
-----------	------

RECHARGEABLE UV FLAW DETECTION LIGHT CODE MPI-HF360



- UV-B content is 0
- Without preheating, instant start, instant on/off, no need to wait
- Supplied with glass filter
- External surface temperature increase <8K (8°C) for continuous working



SPECIFICATION

UV (Light) Lux	about 6000μW/cm ²
UV light power	UV LED-12VA
Covering area	diameter approximately 300mm (calibrated at 381mm distance)
FLUX error	±10% (at 0°C~40°C)
White light content	≤20LUX
Lighting characteristics	center lighting
Wavelength	room temperature 25°C, 365nm±3nm (UVA)
Power supply	12V rechargeable lithium battery
Battery capacity	3500mAh
Charging time	3~4h
Battery life	UV LED 5~6h
Dimension	175×75×170mm
Weight	750g (including battery)

STANDARD DELIVERY

Main unit	1 pc
Battery	2 pcs
Charger	1 pc
Goggles	1 pc

goggles (included)





CMM
Page 167-170



Jigs For CMM
Page 170-172

COORDINATE MEASURING MACHINES



FEATURES

- X&Z axis beam are made of aviation aluminum
- RENISHAW steel scale
- High precision, rigid, pre-loaded air bearings on all axis

RENISHAW UCC CONTROL SYSTEM

- High speed measurement & servo control system

RATIONAL-DMIS SOFTWARE

- Unique operation interface, complete drag-and-drop operation
- Instructional programming allows users to replace text
- Intelligent recognition of the construction, calculation and output of relevant geometric elements
- Seamless link with CAD data

RENISHAW PROBE BODY

- The TP20 is a touch trigger probe
- The TP200B is a touch triggered probe of electronic strain sensing technology, with high measurement accuracy and operate life
- The SP25M is high performance scanning and touch trigger probe



CMM-ST564A

SPECIFICATION

Code	Range (X*Y*Z)	Probe body	MPEE	MPEP	Max. dimension of workpiece	Max. weight of workpiece	Overall dimension	Weight
CMM-ST454A	400×500×400mm	TP20	±(2.1+3.3L/1000)μm	±2.2μm	525×995×600mm	500kg	1000×1240×2240mm	570kg
CMM-ST454B		TP200B	±(1.8+3.3L/1000)μm	±1.9μm				
CMM-ST454C		SP25M						
CMM-ST564A	500×600×400mm	TP20	±(2.1+3.3L/1000)μm	±2.2μm	625×1095×600mm	500kg	1100×1340×2240mm	700kg
CMM-ST564B		TP200B	±(1.8+3.3L/1000)μm	±1.9μm				
CMM-ST564C		SP25M						
CMM-ST686A	600×800×600mm	TP20	±(2.2+3.3L/1000)μm	±2.3μm	730×1400×800mm	700kg	1200×1650×2660mm	960kg
CMM-ST686B		TP200B	±(1.9+3.3L/1000)μm	±2.0μm				
CMM-ST686C		SP25M						
CMM-ST8106A	800×1000×600mm	TP20	±(2.2+3.3L/1000)μm	±2.3μm	930×1600×800mm	1000kg	1400×1850×2660mm	1270kg
CMM-ST8106B		TP200B	±(1.9+3.3L/1000)μm	±2.0μm				
CMM-ST8106C		SP25M						
CMM-ST10128A	1000×1200×800mm	TP20	±(2.7+3.3L/1000)μm	±2.7μm	1190×1814×1040mm	1800kg	1690×2370×3150mm	2460kg
CMM-ST10128B		TP200B	±(2.4+3.3L/1000)μm	±2.4μm				
CMM-ST10128C		SP25M						
CMM-ST10158A	1000×1500×800mm	TP20	±(2.7+3.3L/1000)μm	±2.7μm	1190×2114×1040mm	1800kg	1690×2670×3150mm	2820kg
CMM-ST10158B		TP200B	±(2.4+3.3L/1000)μm	±2.4μm				
CMM-ST10158C		SP25M						
CMM-ST10208A	1000×2000×800mm	TP20	±(2.7+3.3L/1000)μm	±2.7μm	1190×2614×1040mm	1800kg	1690×3270×3150mm	3410kg
CMM-ST10208B		TP200B	±(2.4+3.3L/1000)μm	±2.4μm				
CMM-ST10208C		SP25M						
CMM-ST121510A	1200×1500×1000mm	TP20	±(3.0+3.3L/1000)μm	±3.0μm	1390×2200×1200mm	2000kg	1890×2750×3330mm	3330kg
CMM-ST121510B		TP200B	±(2.7+3.3L/1000)μm	±2.7μm				
CMM-ST121510C		SP25M						
CMM-ST122010A	1200×2000×1000mm	TP20	±(3.0+3.3L/1000)μm	±3.0μm	1390×2700×1200mm	2000kg	1890×3350×3330mm	3910kg
CMM-ST122010B		TP200B	±(2.7+3.3L/1000)μm	±2.7μm				
CMM-ST122010C		SP25M						

To be continued

Continued from previous page

SPECIFICATION

Code	Range (X*Y*Z)	Probe body	MPEE	MPEP	Max. dimension of workpiece	Max. weight of workpiece	Overall dimension	Weight
CMM-ST152010A	1500×2000×1000mm	TP20	±(3.3+3.3L/1000)μm	±3.3μm	1690×2700×1200mm	3000kg	2190×3350×3370mm	5220kg
CMM-ST152010B		TP200B	±(3.0+3.3L/1000)μm	±3.0μm				
CMM-ST152010C		SP25M						
CMM-ST152510A	1500×2500×1000mm	TP20	±(3.3+3.3L/1000)μm	±3.3μm	1690×3200×1200mm	3000kg	2190×3850×3400mm	6680kg
CMM-ST152510B		TP200B	±(3.0+3.3L/1000)μm	±3.0μm				
CMM-ST152510C		SP25M						
CMM-ST153010A	1500×3000×1000mm	TP20	±(3.5+4L/1000)μm	±3.5μm	1690×3700×1200mm	3000kg	2260×3910×3420mm	8120kg
CMM-ST153010B		TP200B	±(3.2+4L/1000)μm	±3.2μm				
CMM-ST153010C		SP25M						
CMM-ST152512A	1500×2500×1200mm	TP20	±(3.5+4L/1000)μm	±3.5μm	1690×3200×1400mm	3000kg	2190×3850×3870mm	6730kg
CMM-ST152512B		TP200B	±(3.2+4L/1000)μm	±3.2μm				
CMM-ST152512C		SP25M						
CMM-ST152515A	1500×2500×1500mm	TP20	±(3.8+4L/1000)μm	±3.8μm	1680×3330×1700mm	3000kg	2190×3980×4500mm	6950kg
CMM-ST152515B		TP200B	±(3.5+4L/1000)μm	±3.5μm				
CMM-ST152515C		SP25M						
CMM-ST153015A	1500×3000×1500mm	TP20	±(4.0+4L/1000)μm	±4.0μm	1680×3830×1700mm	3000kg	2260×4040×4520mm	8440kg
CMM-ST153015B		TP200B	±(3.7+4L/1000)μm	±3.7μm				
CMM-ST153015C		SP25M						
CMM-ST163515A	1600×3500×1500mm	TP20	±(4.0+4L/1000)μm	±4.0μm	1780×4330×1700mm	3000kg	2360×4540×4520mm	9960kg
CMM-ST163515B		TP200B	±(3.7+4L/1000)μm	±3.7μm				
CMM-ST163515C		SP25M						
CMM-ST203015A	2000×3000×1500mm	TP20	±(4.5+4L/1000)μm	±4.5μm	2180×3930×1700mm	6000kg	2760×4240×4520mm	11200kg
CMM-ST203015B		TP200B	±(4.0+4L/1000)μm	±4.0μm				
CMM-ST203015C		SP25M						
CMM-ST203018A	2000×3000×1800mm	TP20	±(4.5+4L/1000)μm	±4.5μm	2180×3930×2000mm	6000kg	2760×4240×5120mm	11200kg
CMM-ST203018B		TP200B	±(4.0+4L/1000)μm	±4.0μm				
CMM-ST203018C		SP25M						

STANDARD DELIVERY

Main unit		1 pc
Probe system	probe head (Renishaw)	1 pc
	probe body (Renishaw)	1 pc
	styli (Renishaw)	1 set
Calibration sphere	Ø19mm	1 pc
Computer		1 pc
Printer		1 pc
Software		1 pc

OPERATION ENVIRONMENT

Air pressure	0.5~1.0MPa
Air supply	0.3~0.45m ³ /min
Temperature	20±2°C
Humidity	55%~65%
Power	220V±10%, 50/60Hz

STYLI INCLUDED IN SP25M

Material	Ball diameter	Length	Quantity
ruby ball/ stainless steel stem	SØ2mm	21mm	2 pcs
	SØ3mm	21mm	2 pcs
	SØ4mm	21mm	2 pcs
	SØ2mm	30mm	2 pcs
	SØ3mm	40mm	2 pcs
	SØ4mm	50mm	2 pcs
	SØ4mm	75mm	2 pcs
	stainless steel stem	—	20mm

PROBE HEAD SPECIFICATION

Probe head (PH10T)	angular movement with horizontal axis	0°~105° in 7.5 steps
	angular movement with vertical axis	±180° in 7.5 steps
	number of positions	720
	probe mounting	M8
	max. output torque	0.45N.m
	max. extension length	300mm
	weight	645g
Probe body	detect direction	±X, ±Y, +Z
	styli mounting	M2
	rating life	>1000000 times

STYLI INCLUDED IN TP20 AND TP200B

Material	Ball diameter	Length	Quantity
ruby ball/ stainless steel stem	SØ1mm	10mm	1 pc
	SØ2mm	20mm	1 pc
	SØ3mm	20mm	1 pc
	SØ3mm	30mm	1 pc
	SØ4mm	10mm	1 pc
	SØ4mm	30mm	1 pc
	SØ4mm	40mm	1 pc
	SØ5mm	20mm	1 pc
stainless steel stem	—	10mm	1 pc
	—	20mm	1 pc
	—	30mm	1 pc

COORDINATE MEASURING MACHINES



FEATURES

- Classic bridge structure, integrated workbench
- High precision air bearing
- Unique Z-axis anti torque design to reduce rotation error

RENISHAW SYSTEMS

- Precision grating system, including grating and data acquisition device
- UCC control system, including control box and manual operator
- Probe system, including probe head, probe body and styli

VISUAL DMIS CNC CAD+SOFTWARE

- The software is designed and developed based on the DMIS standard, with excellent compatibility and versatility
- Geometric element measurement, evaluation of shape and position
- Bidirectional data transfer with mainstream CAD systems, complete graphical display
- Optional specialized modules, such as gear module, worm module, pipeline module, blade module, SPC data analysis module, etc.



CMM-LM564A

SPECIFICATION

Code	Range (X×Y×Z)	Probe system		Accuracy		Max. weight of workpiece	Overall dimension	Weight
		head	body	MPEE	MPEP			
CMM-LM564A	500×600×400mm	MH20i	TP20	±(2.3+L/250)μm	2.4μm	500kg	1420×1135×2350mm	900kg
CMM-LM564B		PH10T						
CMM-LM686A	600×800×600mm	MH20i	TP20	±(2.6+L/250)μm	2.7μm	800kg	1740×1420×2760mm	1300kg
CMM-LM686B		PH10T						
CMM-LM686C		PH10M	SP25M	±(2.1+L/250)μm	2.1μm			
CMM-LM8106A	800×1000×600mm	MH20i	TP20	±(2.7+L/250)μm	2.8μm	1000kg	1940×1620×2760mm	1700kg
CMM-LM8106B		PH10T						
CMM-LM8106C		PH10M	SP25M	±(2.2+L/250)μm	2.2μm			
CMM-LM8126A	800×1200×600mm	MH20i	TP20	±(2.7+L/250)μm	2.8μm		2140×1620×2760mm	1900kg
CMM-LM8126B		PH10T						
CMM-LM8126C		PH10M	SP25M	±(2.2+L/250)μm	2.2μm			
CMM-LM8156A	800×1500×600mm	MH20i	TP20	±(2.7+L/250)μm	2.8μm	2440×1620×2760mm	2200kg	
CMM-LM8156B		PH10T						
CMM-LM8156C		PH10M	SP25M	±(2.2+L/250)μm	2.2μm			

STANDARD DELIVERY

Main unit	1 pc	
Probe system	probe head	1 pc
	probe body	1 pc
	styli	1 set
Control system	1 set	
Calibration sphere	1 pc	
Universal sphere seat	1 pc	
Computer	1 pc	
Printer	1 pc	
Software	1 set	
Table and chair	1 set	

OPERATION ENVIRONMENT

Air pressure	0.6-0.8MPa
Air supply	200L/min
Temperature	20°C±2°C; <0.5°C/h, <1°C/24h
Humidity	30%~70%
Max. power	1000W
Power supply	220V±5%, 50HZ

PH10T AND PH10M SPECIFICATION

Angular movement with horizontal axis	0°~105° in 7.5 steps
Angular movement with vertical axis	±180° in 7.5 steps
Number of positions	720
Steering mode	motorized
Max. output torque	0.45N.m
Max. extension length	300mm
Weight	649g

MH20i SPECIFICATION

Angular movement with horizontal axis	0°~105° in 15 steps
Angular movement with vertical axis	±180° in 15 steps
Number of positions	168
Steering mode	manual
Max. extension length	75mm
Weight	210g

To be continued

Continued from previous page

STYLI SET INCLUDED IN TP20

Name	Material	Ball diameter	Length	Stem diameter	Effective working length	Quantity
Styli	ruby ball/stainless steel stem	SØ2.5mm	20mm	SØ1.4mm	14mm	4 pcs
		SØ4mm		SØ1.5mm	20mm	
		SØ3mm	10mm		7.5mm	1 pc

Name	Material	Diameter	Length	Quantity
Extension	stainless steel	Ø3mm	20mm	1 pc
			30mm	
Center base		Ø7mm	7.5mm	

STYLI SET INCLUDED IN SP25M

Name	Material	Ball diameter	Length	Stem diameter	Effective working length	Quantity
Styli	ruby ball/stainless steel stem	SØ1.5mm	21mm	Ø1mm	14mm	1 pc
		SØ2mm		Ø1.4mm	8mm	1 pc
		SØ3mm		Ø1.5mm	12mm	4 pcs
		SØ4mm	31mm	Ø2.5mm	27mm	1 pc
	ruby ball/carbon fiber stem	SØ5mm	50mm	Ø3mm	42.5mm	1 pc
		SØ6mm	75mm	Ø4mm	75mm	1 pc

Name	Material	Diameter	Length	Quantity
Extension	stainless steel	Ø5mm	10mm	1 pc
		Ø4mm	20mm	
Center base		Ø10mm	13mm	

JIGS FOR CMM (ANVIL Ø2.5mm)

CAN BE CUSTOMIZED

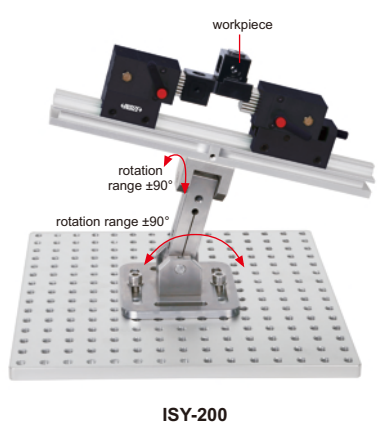

ISY-200-1



ISY-200-2



ISY-200-3



ISY-200-4



ISY-200-5



ISY-200-6

Code	Product	Remark
ISY-200	jig set	including 1 pc ISY-200-1, 1 pc ISY-200-2, 1 pc ISY-200-3, 1 pc ISY-200-4, 1 pc ISY-200-5 and 2 pcs ISY-200-6



Code	Product	Size	Anvil area	Anvil stroke
ISY-200-1	spring anvil	60×40×57	20.5×23	14
ISY-200-2	adjustable spring anvil (range 0-20mm)	70×40×57	20.5×23	14

Code	Product	Size
ISY-200-4	guide	300×40×27
ISY-200-5	two-way adjustable stand	110×110×142
ISY-200-6	clamp handle	—

Code	Product	Size	Hole size
ISY-200-3	base plate	300×300×12	M8

JIG SET FOR CMM CODE ISY-100



ISY-100

application examples

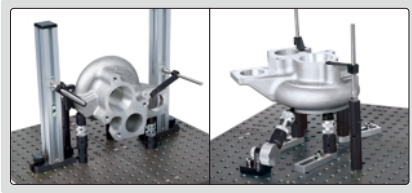





Product	Code	Size (mm)	Quantity	Application
stand	ISY-100-1001	Ø16×30	5	
	ISY-100-1002	Ø16×50	5	
	ISY-100-1003	Ø16×100	3	
stand	ISY-100-1004	Ø20×30	5	
	ISY-100-1005	Ø20×50	5	
	ISY-100-1006	Ø20×100	3	
stand with fine adjustment	ISY-100-2001	Ø16×45~60	2	height adjustment: 45~60mm
stand with fine adjustment	ISY-100-2003	Ø20×45~60	2	
horizontal spring stand	ISY-100-4001	—	2	
horizontal screw stand	ISY-100-5001	—	2	
magnetic stand (magnetic top surface)	ISY-100-7001	Ø20×25	3	
stand for slice parts	ISY-100-8001	Ø20×25	2	ISY-100-8001 and ISY-100-8002 use cooperatively
clamping stand for slice parts	ISY-100-8002		1	
clip	ISY-100-1201	—	2	
clip	ISY-100-1301	—	2	
clip stand	ISY-100-1401	Ø6×60	2	
	ISY-100-1402	Ø6×100	2	
vertical square column	ISY-100-3003	30×30×250	2	

Product	Code	Size (mm)	Quantity	Application
sliding support plate	ISY-100-1801	78×20×10	3	
clamping screw	ISY-100-2301	Ø8×20	6	
screw	ISY-100-2302	Ø8×20	6	
base plate	ISY-600-400200	400×400×12 hole size: M8×1.25 hole center distance: 20	2 pieces	—
wrench	ISY-100-3701	Ø3.8×70	1	—
wrench	ISY-100-3801	M2.5	1	—
	ISY-100-3802	M5	1	—
	ISY-100-3803	M6	1	—
45° stand	ISY-100-9001	—	2	
V shaped support	ISY-100-1901	—	2	
V shaped support	ISY-100-1902	—	2	
marker	ISY-6100-1501	—	52*	
dust cleaner	ISY-100-3501	—	1	—
lubricating oil	ISY-100-3601	—	1	—

* Letter A~Z, number 0~25

To be continued

Continued from previous page

Product	Code	Quantity	Material	Application
	ISY-100-27016	2	aluminum	
	ISY-100-27018	2	nylon	
	ISY-100-27026	2	aluminum	
	ISY-100-27028	2	nylon	
	ISY-100-27036	2	aluminum	
	ISY-100-27038	2	nylon	

Product	Code	Quantity	Material	Application
	ISY-100-27046	2	aluminum	
	ISY-100-27048	2	nylon	
	ISY-100-27056	2	aluminum	
	ISY-100-27058	2	nylon	
	ISY-100-27066	2	aluminum	
	ISY-100-27068	2	nylon	
	ISY-100-27076	2	aluminum	
	ISY-100-27078	2	nylon	

JIG SET FOR CMM CODE ISY-600



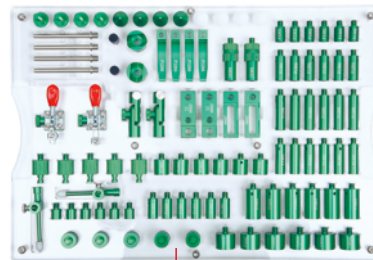





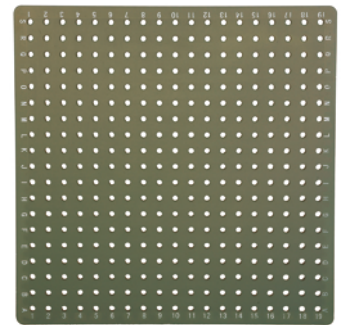

application example









acrylic tray (included)

ISY-600

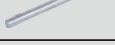

Product	Code	Size (mm)	Quantity
	ISY-600-P1301	Ø13×13	6
	ISY-600-P1302	Ø13×20	6
	ISY-600-P1303	Ø13×26	6
	ISY-600-P1304	Ø13×32	6
	ISY-600-P1305	Ø13×40	6
	ISY-600-P1306	Ø13×45	6
	ISY-600-P1902	Ø20×20	6
	ISY-600-P1905	Ø20×38	6
	ISY-600-P2602	Ø26×20	6
	ISY-600-P1522	—	2
	ISY-600-J1560	—	2
	ISY-600-J1501	48~60	2
 (magnetic top surface)	ISY-600-J2020	Ø20×20	4
	ISY-600-J2021	Ø20×19	2
	ISY-600-J2520	Ø25×20	2
	ISY-600-P2003	M8x1.25	4

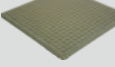
Product	Code	Size (mm)	Quantity
	ISY-600-J2060	60×20×10	2
	ISY-600-J2060-2	60×20×10	2
	ISY-600-P1266	12×66	4
	ISY-600-JS201	—	2
	ISY-600-P0684	Ø6×74	4
	ISY-600-P2002	—	4
	ISY-600-P2001	—	4
	ISY-600-400	400×400×18 hole size: M8X1.25	1



Profile Projectors
Page 174



Quick Measurement Systems
Page 175-176



Vision Measuring Systems
Page 177-178

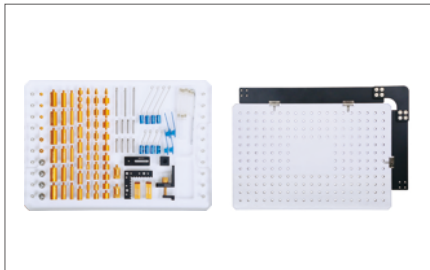

Jig Sets For Vision Measuring Systems
Page 179

PROFILE PROJECTOR CODE ISP-Z3015



OPTIONAL ACCESSORY



lens



holder with clamp



demo sample

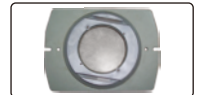

rotary table
(glass plate diameter 100mm)



swivel center support



V-block with clamp



blue filter



50mm reading scale
(check magnification accuracy)

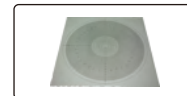

overlay chart
(protractor with 1° graduation,
radius with 1mm increment)



300mm calibration scale
(check magnification accuracy
together with 50mm reading
scale or calibrate
measuring accuracy)

SPECIFICATION

Lens	magnification	10X (included)	20X (optional)	50X (optional)	100X (optional)
	view field	Ø30mm	Ø15mm	Ø6mm	Ø3mm
	working distance	77.7mm	44.3mm	38.4mm	25.3mm
Max. workpiece height		90mm	90mm	90mm	90mm
Magnification accuracy		±0.08%			
Image		erect image			
Projector screen		diameter: Ø300mm			
		rotation range: 0°~360°, resolution: 1" or 0.01°			
		reference lines: cross-hairs			
Stage	metal stage size	340×152mm			
	glass stage size	196×96mm			
	X-Y stage travel	range: 150×50mm			
		resolution: 0.5µm			
	Z (focus) travel range	accuracy: (4+L/25)µm L is the measuring length in mm			
max. load capacity	90mm				
Illumination		contour illumination: 24V/150W halogen lamp, brightness is adjustable			
		surface illumination: 24V/150W halogen lamp			
Data processing unit	display	X-Y stage travel, screen rotation			
	output	RS232C			
Data processing unit	function	measure coordinate of point			
		measure coordinate of line			
		measure center coordinate, radius of circle with three points			
		measure distance between two objects			
		measure angle with four points or two lines			
		set origin of coordinate			
		coordinate transform			
		set midpoint of coordinate			
Power supply		110/220V, 50/60Hz			
Dimension (L×W×H)		550×770×1100mm			
Weight		135kg			

STANDARD DELIVERY

Main unit	1 pc
10X lens with half-reflection mirror and oblique illuminator mirror	1 pc
Overlay chart clip	4 pcs
Foot-switch	1 pc
Anti-dust cover	1 pc

OPTIONAL ACCESSORY

20X lens with half-reflection mirror and oblique illuminator mirror	ISP-Z3015-LENS20X
50X lens with half-reflection mirror	ISP-Z3015-LENS50X
100X lens with half-reflection mirror	ISP-Z3015-LENS100X
Rotary table	ISP-Z3015-TABLE
Overlay chart	ISP-Z3015-CHART
Holder with clamp	ISP-Z3015-HOLDER
Swivel center support	ISP-Z3015-SUPPORT
V-block with clamp	ISP-Z3015-VBLOCK
50mm reading scale	ISP-Z3015-SCALE50
300mm calibration scale	ISP-Z3015-RULE
Blue filter	ISP-Z3015-FILTER
Demo sample	ISP-Z3015-DEMO

QUICK MEASUREMENT SYSTEM (WITHOUT STITCHING) CODE QMS-A110

NOTE: NOT SUITABLE FOR SMALL SIZES
SUCH AS THREADS, CHAMFERS, ETC



- One or more workpieces can be measured by one step operation
- Place workpieces at any position
- Focus and measure automatically
- Measurement of 999+dimensions and 200+workpieces
- Suitable for measuring small flat parts



SPECIFICATION

Optical lens	low-distortion lens, single-field telecentric Ø100mm	
View field range	100×80mm	
Measurement range (X×Y)	98×78mm	
Measurement accuracy *	±3µm	
Repeatability	±1µm	
Max. weight of workpiece	5kg	
Measurement time	<2s	
Measurement data	2D measurement	
Power supply	220V, 50Hz, 600W	
Illumination system	back light	telecentric illuminator, green light
	ring light	4-zone circular white high light circular (directional) low-angle green light (electric)
	coaxial light (optional)	vertical illuminator, white light
Environmental requirement	temperature: 20°C±2°C, relative humidity: 30%~80%, vibration: <0.002g, less than 15Hz	
Dimension (L×W×H)	580×235×790mm	
Weight	40kg	

* The optimum temperature is 20°C±1°C
Within 80×64mm, on focal position and environment temperature at 20°C±1°C

STANDARD DELIVERY

Main unit	1 pc
Computer	1 pc
Software	1 pc

OPTIONAL ACCESSORY

Coaxial light illumination	QMS-23-A3
Data transmission function of software	QMS-23-D1
CAD import function of software	QMS-23-C1
Foot-switch	QMS-43-FS1
11.6" LCD	QMS-23-B1 (must be installed in factory)



11.6" LCD (optional)

Software (included)

- Automatically measure widths, holes, rings, angles at the same time, simple and efficient.
- Measuring result can be stored automatically. OK items and NG items can be counted automatically.

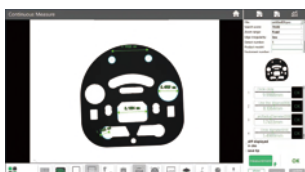

QUICK MEASUREMENT SYSTEM (WITH STITCHING) CODE QMS-A220

SMALL VIEW FIELD SUITABLE FOR SMALL SIZES SUCH AS THREADS, CHAMFERS, ETC

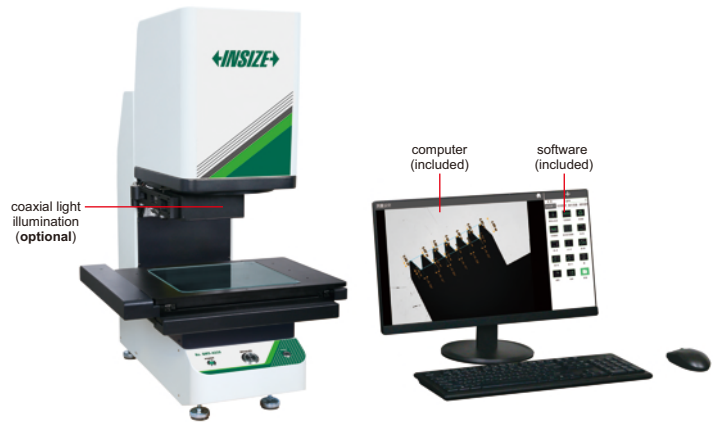

- One or more workpieces can be measured by one step operation
- Place workpieces at any position
- Focus and measure automatically
- Measurement of 999+dimensions and 200+workpieces
- Suitable for small and medium-size parts with high precision requirements

SPECIFICATION

Optical lens		dual-field dual-telecentric low-distortion lens	
		wide view field: Ø100mm small view field: Ø25mm	
View field range		wide view field	small view field
		93×62mm	20×16mm
Measurement range		200×200mm	130×130mm
Measurement accuracy	without stitching	±3µm ①	±1µm ②
	with stitching	±(5+0.02L)µm ③	±(3+0.02L)µm ④
Repeatability	without stitching	±1µm	±0.5µm
	with stitching	±2µm	±1.5µm
Max. weight of workpiece		5kg	
Measurement time		<2s	
Measurement data		2D measurement	
Power supply		220V, 50Hz, 600W	
Illumination system	back light	telecentric illuminator, green light	
	ring light	4-zone circular white high light circular (directional) low-angle green light (electric)	
	coaxial light (optional)	vertical illuminator, white light	
Environmental requirement		temperature: 20°C±2°C, relative humidity: 30%~80%, vibration: <0.002g, less than 15Hz	
Dimension (L×W×H)		532×480×766mm	
Weight		50kg	



11.6" LCD (optional)

* The optimum temperature is 20°C±1°C

① Within 80×64mm, on focal position and environment temperature at 20°C±1°C

② Within 20×16mm, on focal position and environment temperature at 20°C±1°C

③ Within 180×180mm, on focal position, environment temperature at 20°C±1°C, and workpiece is less than 2kg, L is the travel of stage

④ Within 117×117mm, on focal position, environment temperature at 20°C±1°C, and workpiece is less than 2kg, L is the travel of stage

OPTIONAL ACCESSORY

Coaxial light illumination	QMS-23-A3
Data transmission function of software	QMS-23-D1
CAD import function of software	QMS-23-C1
Foot-switch	QMS-43-FS1
11.6" LCD	QMS-23-B1 (must be installed in factory)

STANDARD DELIVERY

Main unit	1 pc
Computer	1 pc
Software	1 pc

Software (included)

- Automatically measure widths, holes, rings, angles at the same time, simple and efficient.
- Measuring result can be stored automatically. OK items and NG items can be counted automatically.

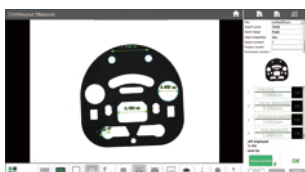

VISION MEASURING SYSTEMS (MANUAL TYPE)



ISD-V250A

computer is included



lens with coaxial light (optional, must be installed in factory)

SPECIFICATION

Code	ISD-V150A	ISD-V250A	ISD-V300A
Measuring range (X×Y×Z)	150×100×150mm	250×150×150mm	300×200×150mm
Stage size	354×228mm	450×280mm	500×330mm
Glass stage size	210×160mm	306×196mm	350×250mm
Resolution of X/Y/Z axis	0.5μm		
Accuracy of X/Y axis	≤(3.5+L/100)μm (L is the measuring length in mm)		
Repeatability of X/Y axis	2μm		
Objective	0.7X~4.5X (zoom)		
Working distance	92mm		
Magnification	33X~195X (on 19" monitor)		
Camera	1/3" color CCD, 0.3M pixel		
Illumination	surface and contour with adjustable LED		
Max. height of workpiece	150mm		
Max. weight of workpiece	20kg		
Operation system	Windows 7/8/10		
Drive method	manual		
Power supply	110/220V, 50/60Hz		
Dimension (L×W×H)	560×540×850mm	760×600×900mm	760×600×900mm
Weight	100kg	120kg	140kg

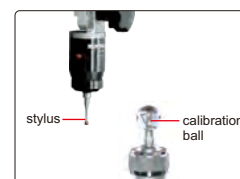

probe (optional), includes Ø2mm and Ø3mm styli, Ø25mm calibration ball, measuring accuracy is 10μm

STANDARD DELIVERY

Main unit	1 pc
Computer	1 pc
Calibration glass chart	1 pc
Clay	1 pc
Foot switch	1 pc
Anti-dust cover	1 pc

OPTIONAL ACCESSORY

0.5X auxiliary objective	code: ISD-V-OB05X working distance: 175mm magnification: 16.5~97.5X (on 19" monitor)
2X auxiliary objective	code: ISD-V-OB2X working distance: 36mm magnification: 66~390X (on 19" monitor)
Probe	code: ISD-V-PROBE includes Ø2mm and Ø3mm styli, Ø25mm calibration ball
Vision measuring system with coaxial light lens (with computer)	code: ISD-V150ACL, ISD-V250ACL, ISD-V300ACL
Office software	code: 7313-OFFICE

SOFTWARE (INCLUDED)

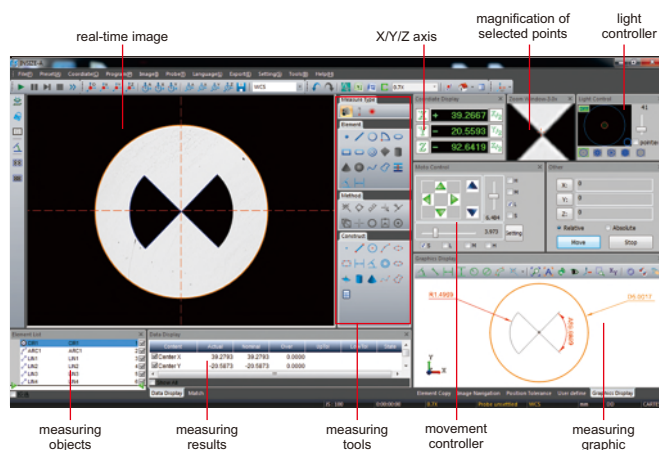

CNC VISION MEASURING SYSTEM

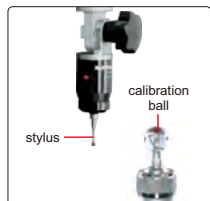

probe (optional), includes Ø2mm and Ø3mm styli, Ø25mm calibration ball, measuring accuracy is 10µm



laser probe (optional) measuring accuracy is 5µm



lens with built-in coaxial light (included)

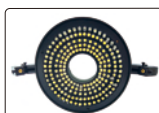

programmable segmented ring light (included)



ISD-V220CNCA

controller



software flash disk (included)

computer is included



- Automatic edge-detection, focus, measuring, contour scanning, calibration, etc.
- Servo motors for X, Y, Z axis
- SPC function for large quantity measurement
- Measuring software is included

SPECIFICATION

Code (manual zoom lens)	ISD-V220CNCA	
Measuring range (X*Y*Z)	220×120×150mm	
Stage size	450×280mm	
Glass stage size	306×196mm	
Resolution of X/Y/Z axis	0.5µm	
Accuracy of X/Y axis	≤(2.5+L/100)µm (L is the measuring length in mm)	
Repeatability of X/Y axis	2µm	
Objective	0.7X~4.5X (zoom)	
Working distance	92mm	
Magnification	33.0X~208.6X (with manual zoom lens, on 24" monitor); 31.9X~188.7X (with motorized zoom lens, on 24" monitor)	
Camera	giga-bit network camera	
Illumination	surface	coaxial light, programmable segmented ring light
	contour	adjustable LED light
View field (diagonal length)	1.5~10.8mm	
Max. height of workpiece	150mm	
Max. weight of workpiece	30kg	
Operation system	Windows 7/8/10	
Drive method	automatic	
Power supply	220V, 50/60Hz	
Dimension (L*W*H)	760×600×900mm	
Weight	146kg	



desk (optional)

STANDARD DELIVERY

Main unit	1 pc
Software	1 pc
Computer	1 pc
24" display	1 pc
Len with coaxial light	1 pc
Controller	1 pc
Calibration glass chart	1 pc
Laser positioner	1 pc
Clay	1 pc
Anti-dust cover	1 pc

OPTIONAL ACCESSORY

0.5X auxiliary objective	code: ISD-V-OB05X working distance: 175mm magnification: 16.5~104.3X (with manual zoom lens, on 24" monitor), 16.0~94.4X (with motorized zoom lens, on 24" monitor)
2X auxiliary objective	code: ISD-V-OB2X working distance: 36mm magnification: 66~417.2X (with manual zoom lens, on 24" monitor), 63.8~377.4X (with motorized zoom lens, on 24" monitor)
Probe	code: ISD-V-PROBE includes Ø2mm and Ø3mm styli, Ø25mm calibration ball
Laser probe	code: ISD-V-LASER
Office software	code: 7313-OFFICE
Desk	code: ISD-V-DESK

SOFTWARE (INCLUDED)

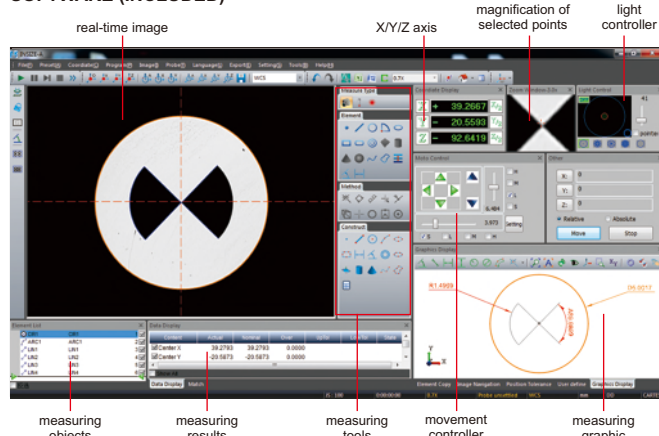

JIG SET FOR VISION MEASURING SYSTEMS CODE ISY-700

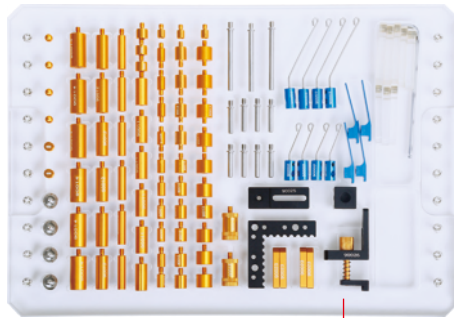



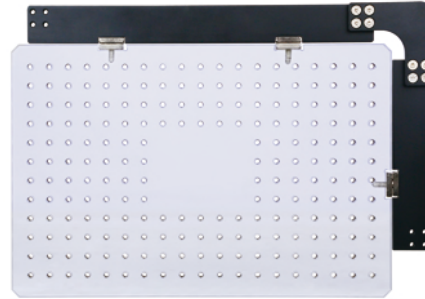





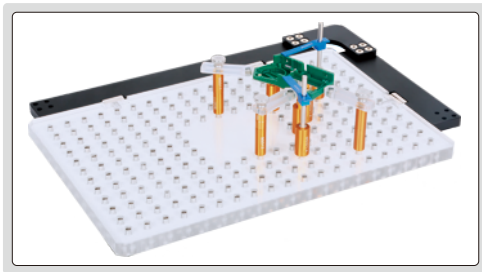

acrylic tray (included)



ISY-700

application example



Product	Code	Size (mm)	Quantity
clip 	ISY-700-90001	7×34	4
clip 	ISY-700-90002	Ø1.5×24	4
	ISY-700-90003	Ø1.5×50	4
clip stand 	ISY-700-90004	Ø4×20	8
	ISY-700-90005	Ø4×46	3
spherical support head 	ISY-700-90006	—	4
stand 	ISY-700-90007	Ø6×10	6
	ISY-700-90008	Ø6×25	6
	ISY-700-90019	Ø6×6	3
stand 	ISY-700-90009	Ø9×7	3
	ISY-700-90010	Ø9×10	6
	ISY-700-90011	Ø9×20	6
	ISY-700-90012	Ø9×25	6
stand 	ISY-700-90013	Ø12×10	6
	ISY-700-90014	Ø12×25	6
stand for slice parts 	ISY-700-90015	Ø6×10	4
	ISY-700-90016	Ø9×10	4
	ISY-700-90017	Ø12×10	4
stand with fine adjustment 	ISY-700-90018	Ø12×20~25	2

Product	Code	Size (mm)	Quantity
adapter for square support 	ISY-700-90020	—	2
clamping screw 	ISY-700-90021	—	4
L-shaped positioning plate 	ISY-700-90022	50×50×6	1
sliding support plate 	ISY-700-90023	30×12×5	4
square support 	ISY-700-90024	20×16×16	1
base for square support 	ISY-700-90025	45×16×6	1
spring stand 	ISY-700-90026	—	1
acrylic sliding support plate 	ISY-700-90028	45×12×5	8
wrench 	ISY-700-90029	M3	1
acrylic base plate 	ISY-700-90030	300×200×12 hole size: M4×0.7	1



Toolmaker Microscopes
Page 181



Digital Microscopes
Page 182-191

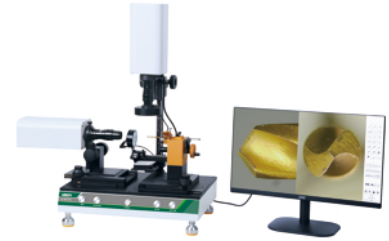

Cutting Tools Microscopes
Page 187



Metallurgical Microscopes
Page 192-193



Zoom Stereo Microscopes
Page 193-195



Portable Measuring Microscopes
Page 196



Table Magnifiers With Illumination
Page 196



Digital Magnifiers
Page 197



Magnifiers
Page 197-199



Telescoping Inspection Mirrors
Page 200



Telescoping Pick-up
Page 200



TOOLMAKER MICROSCOPE

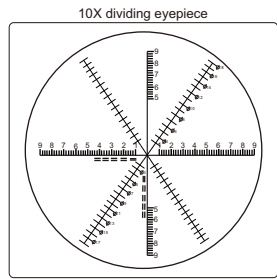
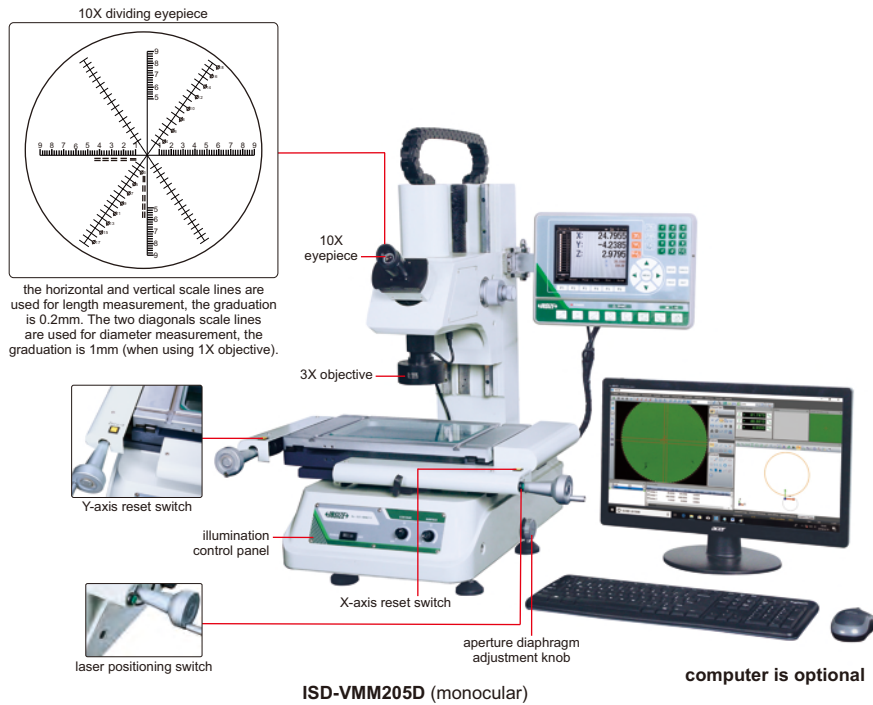

the horizontal and vertical scale lines are used for length measurement, the graduation is 0.2mm. The two diagonals scale lines are used for diameter measurement, the graduation is 1mm (when using 1X objective).

ISD-VMM205D (monocular)

computer is optional

SPECIFICATION

Code	ISD-VMM205D (monocular)
X/Y axis travel	150×100mm
Z axis travel	150mm
Metal stage size	354×228mm
Glass stage size	210×160mm
Resolution of X/Y/Z axis	0.5μm
Accuracy of X/Y axis	≤(3.5+L/100)μm (L is the measuring length in mm)
Repeatability	2μm
Camera	1/3" color CCD, 0.3M pixel
Optical magnification	30X (with 3X objective)
Image magnification	114X (on 19" monitor)
Illumination	surface and contour with adjustable LED
Max. weight of workpiece	25kg
Power supply	100V~240V, 50/60Hz
Operation system	Windows 7/8/10
Drive method	manual
Dimension (L×W×H)	540×667×850mm
Weight	100kg

DATA PROCESSING UNIT

Output	RS232
Function	simple measuring tools
	measure coordinate of points
	measure lines
	measure center coordinate, radius of circle with three points
	measure distances between two objects
	measure angles
	set origin of coordinate
	skew and calibrate the workpiece
	measure rectangle (including length, width, perimeter and center coordinate)
	measure thread (including thread diameter, screw pitch, screw angle)
	measure slot (including center coordinate, length, width)

STANDARD DELIVERY

Main unit	1 pc
Video card with dongle	1 pc
Software disc	1 pc
Calibration glass chart	1 pc
Demo sample	1 pc
Foot switch	1 pc
3X objective	1 pc

OPTIONAL ACCESSORY

1X objective	ISD-VMM-LENS1X
5X objective	ISD-VMM-LENS5X
10X objective	ISD-VMM-LENS10X
Toolmaker microscopes (with computer)	code: ISD-VMM205DA (monocular)

SOFTWARE (INCLUDED)

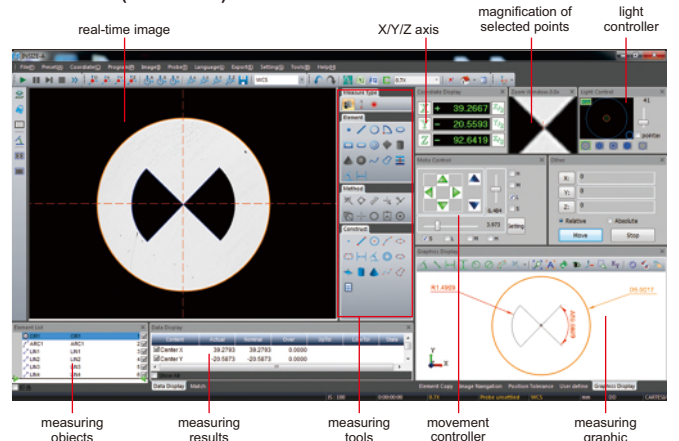

AUTO FOCUS DIGITAL MICROSCOPE (LARGE VIEW FIELD) CODE 5302-AF105

CAN BE CONNECTED TO PC
AND TV AT THE SAME TIME

MEASUREMENT

AUTO FOCUS

TAKE PICTURES
AND VIDEOS



- Auto focus camera
- Take pictures and videos
- Can be connected to TV (HDMI port) and computer (RJ45 port) at the same time
- Built-in measuring software for TV
- Measuring software for computers is included
- Automatic exposure and white balance
- Brightness, contrast ratio, gain are adjustable
- Display cross hair (blue/green/red/yellow/black/brown colors)

SPECIFICATION

Code	5302-AF105 (standard type)
Pixel	2M
Resolution	1920×1080
Magnification	1.4X~25.8X (on 28" TV)
Sensor	1/2.8" CMOS
Auto focus distance	100mm~∞
Output	HDMI, RJ45
Frame rate	HDMI: 60fps, RJ45: 50fps
Power supply	power adapter
Dimension (L×W×H)	500×280×410mm
Weight	17kg

STANDARD DELIVERY

Main unit (with stand)	1 pc
LED illumination	1 pc
16G USB flash disk	1 pc
Mouse	1 pc
HDMI cable (for TV)	1 pc
Network cable (for computer)	1 pc
Switch	1 pc
Software for computer	1 pc
Power adapter	2 pcs

VIEW FIELD

Focus distance	Adjustable magnification (on 28" TV)	View field
100mm	3.9~25.8X	24×14~168×91mm
150mm	2.6~20X	30×17~240×128mm
200mm	2.1~17X	37×20~315×170mm
250mm	1.7~14.7X	42×24~385×210mm
270mm	1.4~14X	43×25~415×225mm

controller (optional, for TV)

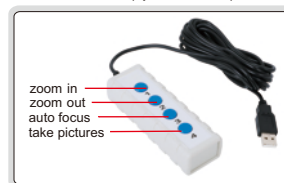

TV SOFTWARE (INCLUDED)

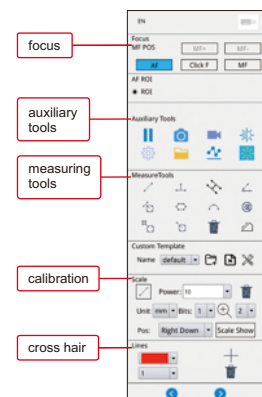

MEASURING ACCURACY

Optical magnification	Measuring accuracy
2X	±0.1mm
4X	±0.1mm
6X	±0.04mm
8X	±0.02mm
14X	±0.02mm

OPTIONAL ACCESSORY

28" 4K TV	5302-AF-TV28
32" 4K TV	5302-AF-TV32
Computer	5302-AF-COMPUTER
Controller	5302-AF-CONTROLLER

3D MANUAL ROTATION MICROSCOPE CODE 5313-S407



SUITABLE TO CHECK CONVEX
OBJECTS AND WALL OF HOLES

TAKE PICTURES
AND VIDEOS

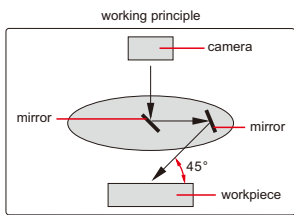
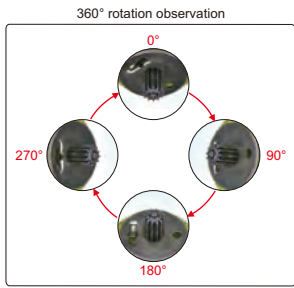
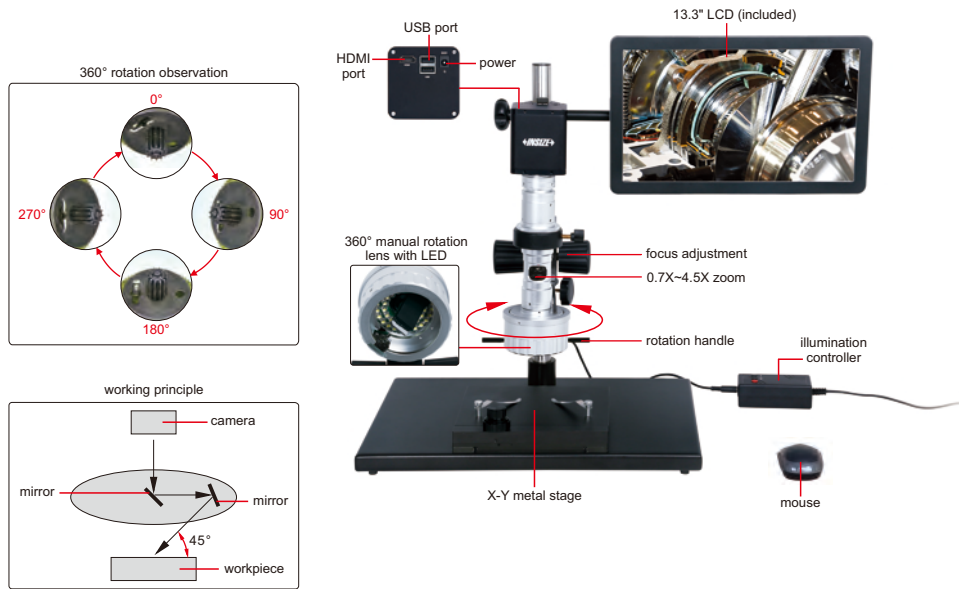

SPECIFICATION

Magnification	18X~120X
View field	2.4×1.5mm~16×9mm
Focus distance	20mm
View angle	45°
Sensor	1/2.8" CMOS
Pixel	2M
Resolution	1920×1080
Frame rate	60fps
Output	HDMI
Power supply	220V, 50/60Hz
Dimension (L×W×H)	570×300×430mm
Weight	10kg

STANDARD DELIVERY

Main unit	1 pc
X-Y metal stage	1 pc
16G USB flash disk	1 pc
White/black plate	1 pc
Mouse	1 pc
Power adapter	2 pcs

DIGITAL MEASURING MICROSCOPE (BASIC TYPE) CODE 5318-MD60

MEASUREMENT

TAKE PICTURES

BUILT-IN SOFTWARE
WITHOUT COMPUTER

- 1080P high-definition image
- Built-in software without computer, operated by mouse
- Take pictures, save to USB flash disk
- Measurement results can be sent to Excel
- Brightness, contrast ratio, gain are adjustable



POPULAR
MODEL

SPECIFICATION

Magnification	12.5X~80X
Sensor	1/2.8" CMOS
Pixel	2M
Resolution	1920×1080
Frame rate	60fps
Measuring accuracy	±0.02mm
Lines	cross lines, scale lines (number, color and position of lines are adjustable)
Output	HDMI
Power supply	power adapter
Dimension (L×W×H)	380×260×350mm
Weight	4.5kg

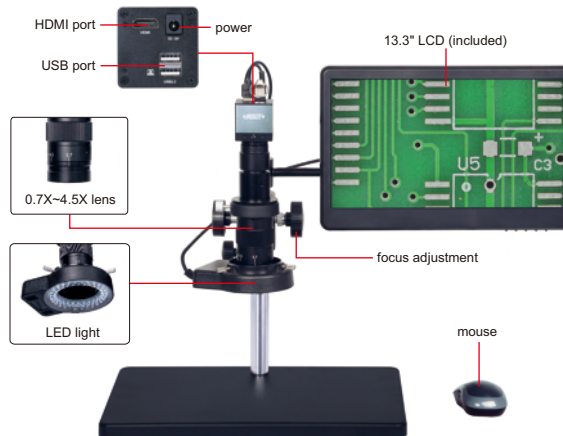

STANDARD DELIVERY

Main unit	1 pc
0.5X camera adapter	1 pc
1X auxiliary objective	1 pc
White/black plate	1 pc
Glass calibration rule	1 pc
16G USB flash disk	1 pc
Mouse	1 pc
HDMI cable	1 pc
Power adapter	3 pcs

MAGNIFICATION AND VIEW FIELD

Auxiliary objective	Specification	Camera adapter
		0.5X (included)
0.5X (optional)	magnification	6.2~40X
	view field	47×26~7.4×4mm
1X (included)	magnification	12.5~80X
	view field	23.5×13~3.7×2mm
2X (optional)	magnification	25~160X
	view field	11.8×6.5~1.8×1mm

OPTIONAL ACCESSORY

0.5X auxiliary objective	5318-OB05X
2X auxiliary objective	5318-OB2X



glass calibration rule
(graduation 0.1mm,
included)



white/black plate
(included)



16G USB flash disk
(included)

MEASURING SOFTWARE (INCLUDED)

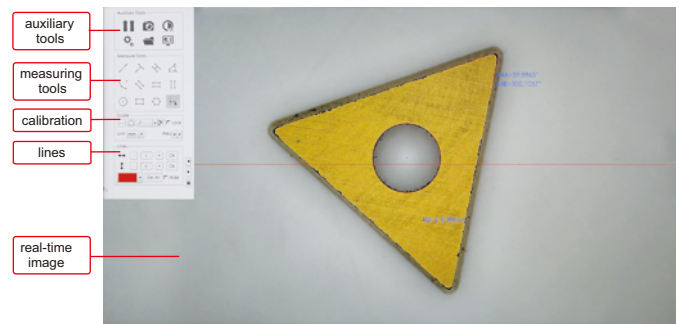

DIGITAL MEASURING MICROSCOPE

TAKE PICTURES MEASUREMENT BUILT-IN SOFTWARE WITHOUT COMPUTER

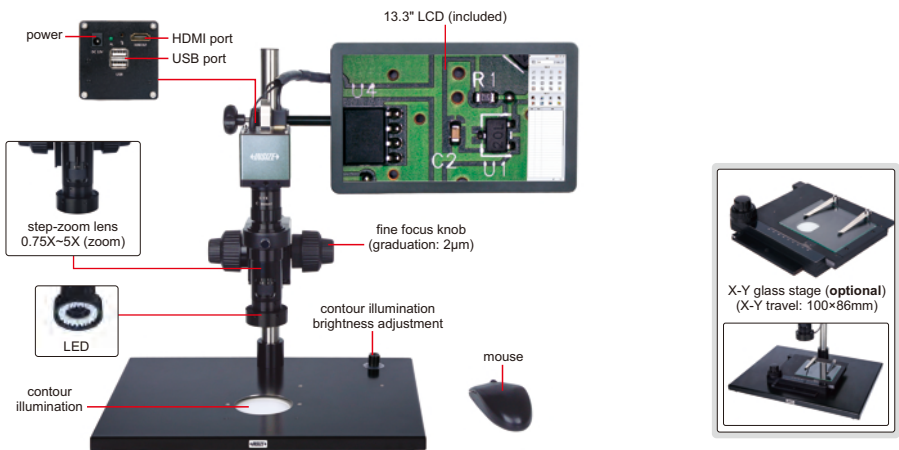

ISM-DL301 (with contour illumination)

- 1080P high-definition image
- Built-in software without computer, operation by mouse
- Take pictures, saved to USB flash disk
- Measurement results can be output to Excel
- Automatic white balance and exposure
- Brightness, contrast ratio, gain are adjustable

SPECIFICATION

Code	ISM-DL301 (with contour illumination)
Magnification	15X~100X
Sensor	1/2" CMOS
Pixel	2M
Resolution	1920×1080
Frame rate	60fps
Output	HDMI
Power supply	power adapter
Dimension (L×W×H)	570×300×430mm
Weight	6.5kg



STANDARD DELIVERY

Main unit	1 pc
0.5X camera adapter	1 pc
1X auxiliary objective	1 pc
Calibration plate	1 pc
16G USB flash disk	1 pc
White/black plate	1 pc
Mouse	1 pc
HDMI cable	1 pc
Power adapter	3 pcs

MAGNIFICATION AND MEASURING ACCURACY

Objective magnification	Image magnification	Measuring accuracy
0.75X	15X	±8µm
1X	20X	±7µm
1.5X	30X	±6µm
2X	40X	±6µm
2.5X	50X	±6µm
3X	60X	±5µm
3.5X	70X	±5µm
4X	80X	±4µm
4.5X	90X	±4µm
5X	100X	±4µm

OPTIONAL ACCESSORY

1X camera adapter	ISM-DL-CA1X
2X auxiliary objective	ISM-DL-OB2X
X-Y glass stage (travel: 100×86mm)	ISM-DL-STAGE
X-Y metal stage	ISM-DL-STAGE1
LED light	see details
Auxiliary objective	see details

MAGNIFICATION, FOCUS DISTANCE AND VIEW FIELD

Auxiliary objective	Specification	Camera adapter	
		0.5X (included)	1X (optional)
1X (included)	magnification	15~100X	30~200X
	focus distance	70±2mm	70±2mm
	view field	16×11~2.5×1.6mm	7.8×5.3~1.2×0.8mm
2X (optional)	magnification	30~200X	60~400X
	focus distance	29±2mm	29±2mm
	view field	7.8×5.3~1.2×0.8mm	3.8×2.7~0.6×0.4mm

SOFTWARE (INCLUDED)

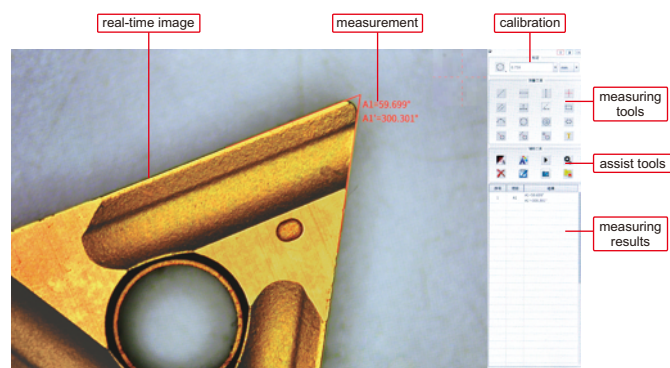

AUTO FOCUS DIGITAL MICROSCOPE CODE 5303-AF103

- 1080P high-definition image
- Auto focus camera
- Take pictures and videos, saved to USB flash disk
- Picture review, picture compare
- Automatic exposure and white balance
- Brightness, contrast ratio, gain are adjustable
- Display cross hair (blue/green/red/yellow/black/brown colors)
- Built-in software without computer, operation by mouse

SPECIFICATION

Magnification	20X~123X
Sensor	1/2.8" CMOS
Pixel	2M
Resolution	1920×1080
Frame rate	60fps
Output	HDMI
Power supply	power adapter
Dimension (L×W×H)	570×300×430mm
Weight	6.5kg

STANDARD DELIVERY

Main unit	1 pc
0.5X camera adapter	1 pc
1X auxiliary objective	1 pc
Calibration plate	1 pc
16G USB flash disk	1 pc
White/black plate	1 pc
Mouse	1 pc
HDMI cable	1 pc
Power adapter	2 pcs

AUTO FOCUS DISTANCE

Zoom objective scale	0.75X	1X	1.5X	2X	2.5X	3X	3.5X	4X	4.5X	5X
Auto focus distance	48~84mm	50~78mm	55~73mm	62~71mm	65~70mm	66~70mm	67~70mm	68~70mm	68~70mm	68~70mm

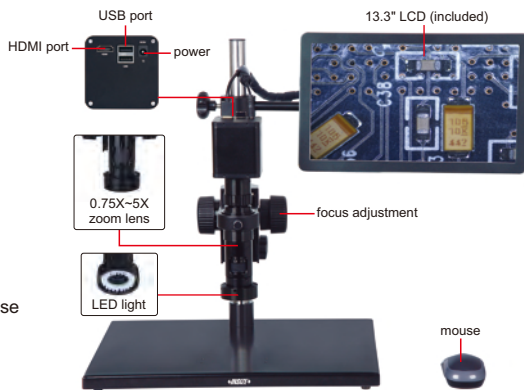

MEASUREMENT

AUTO FOCUS

TAKE PICTURES AND VIDEOS

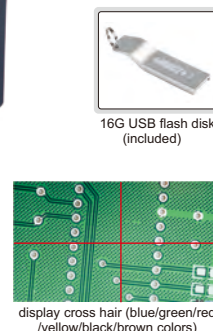

MAGNIFICATION, FOCUS DISTANCE AND VIEW FIELD

Auxiliary objective	Specification	Camera adapter	
		0.5X (included)	1X (optional)
1X (included)	magnification	20~123X	40~246X
	focus distance	48~84mm	48~84mm
	view field	13×7~2.2×1mm	6.3×3.5~1.1×0.5mm
	measuring accuracy	±0.02mm	±0.02mm
2X (optional)	magnification	40~246X	80~492X
	focus distance	24~42mm	24~42mm
	view field	6.5×3.5~1.1×0.5mm	3.3×1.8~0.6×0.3mm
	measuring accuracy	±0.02mm	±0.02mm

OPTIONAL ACCESSORY

1X camera adapter	ISM-DL-CA1X
2X auxiliary objective	ISM-DL-OB2X
X-Y glass stage (travel: 100×86mm)	ISM-DL-STAGE
X-Y metal stage	ISM-DL-STAGE1
LED light	see details
Auxiliary objective	see details



HORIZONTAL MICROSCOPE CODE 5316-HM810

- 1080P high-definition image
- Built-in software without computer, operated by mouse
- Take pictures, save to USB flash disk
- Automatic white balance and exposure
- Brightness, contrast ratio, gain are adjustable
- Display cross hair (blue/green/red/yellow/black/brown colors)

SPECIFICATION

Magnification	10.5X~62.5X
View field	4.5×2.5~28×12.3mm
Focus distance	115mm
Measuring accuracy	±0.02mm
Sensor	1/2.8" CMOS
Pixel	2M
Resolution	1920×1080
Frame rate	1080P: 60fps/50fps
Output	HDMI
Power supply	110/220V, 50/60Hz
Dimension (L×W×H)	500×200×200mm
Weight	7kg

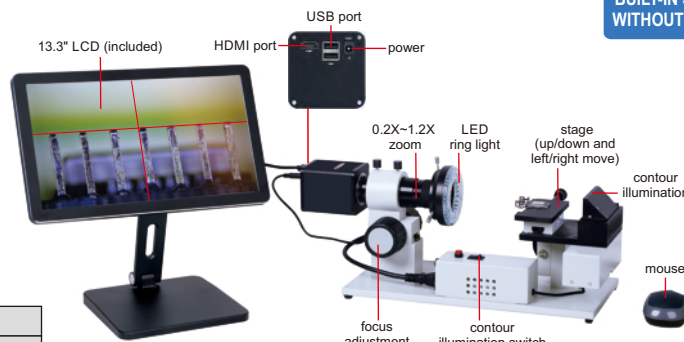

BUILT-IN SOFTWARE WITHOUT COMPUTER

TAKE PICTURES



SOFTWARE (INCLUDED)

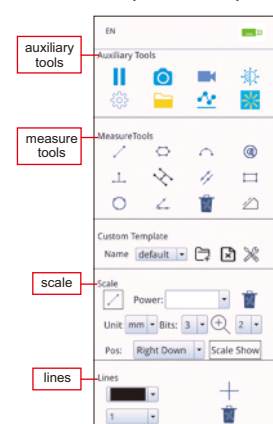

STANDARD DELIVERY

Main unit	1 pc
1X camera adapter	1 pc
1X auxiliary adapter	1 pc
Plastic calibration rule	1 pc
16G USB flash disk	1 pc
Mouse	1 pc
LED ring light	1 pc

FLEXIBLE ARM AUTO FOCUS DIGITAL MICROSCOPES

MEASUREMENT

AUTO FOCUS

TAKE PICTURES AND VIDEOS

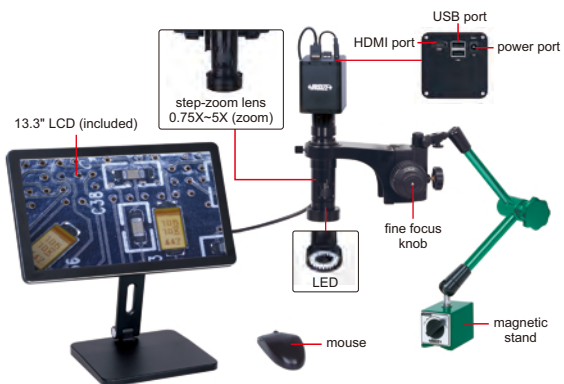

5317-AF109

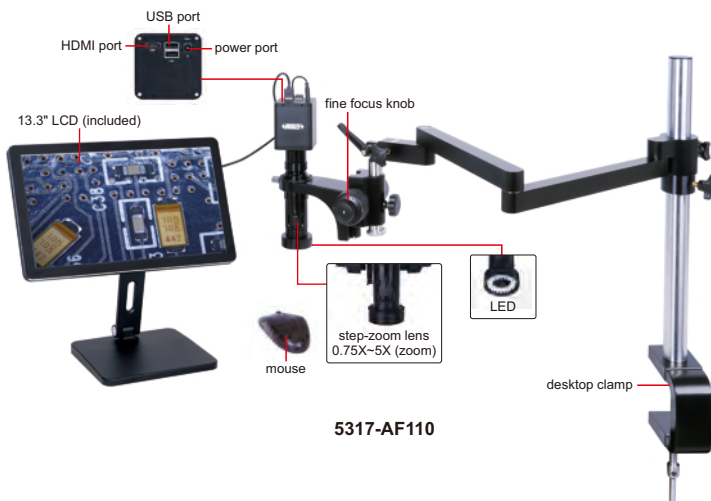

5317-AF110

- 1080P high-definition image
- Auto focus camera
- Take pictures and videos, saved to USB flash disk
- Picture review, picture compare
- Automatic exposure and white balance
- Brightness, contrast ratio, gain are adjustable
- Display cross hair (blue/green/red/yellow/black/brown colors)
- Built-in software without computer, operation by mouse
- Flexible arm

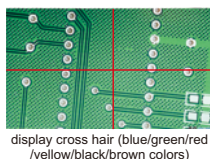

SPECIFICATION

Code	5317-AF109 (with magnetic stand)	5317-AF110 (with desktop clamp)
Magnification	20X~123X	
Sensor	1/2.8" CMOS	
Pixel	2M	
Resolution	1920×1080	
Frame rate	60fps	
Power supply	power adapter	
Dimension (height)	480mm	600mm
Weight	5.6kg	8.5kg

MAGNIFICATION, FOCUS DISTANCE AND VIEW FIELD

Auxiliary objective	Specification	Camera adapter	
		0.5X (included)	1X (optional)
1X (included)	magnification	20~123X	40~246X
	focus distance	48~84mm	48~84mm
	view field	13×7~2.2×1mm	6.3×3.5~1.1×0.5mm
	measuring accuracy	±0.02mm	±0.02mm
2X (optional)	magnification	40~246X	80~492X
	focus distance	24~42mm	24~42mm
	view field	6.5×3.5~1.1×0.5mm	3.3×1.8~0.6×0.3mm
	measuring accuracy	±0.02mm	±0.02mm

AUTO FOCUS DISTANCE

Zoom objective scale	0.75X	1X	1.5X	2X	2.5X	3X	3.5X	4X	4.5X	5X
Auto focus distance	48~84mm	50~78mm	55~73mm	62~71mm	65~70mm	66~70mm	67~70mm	68~70mm	68~70mm	68~70mm

STANDARD DELIVERY

Main unit	1 pc
0.5X camera adapter	1 pc
1X auxiliary objective	1 pc
Calibration plate	1 pc
16G USB flash disk	1 pc
White/black plate	1 pc
Mouse	1 pc
HDMI cable	1 pc
Power adapter	2 pcs

OPTIONAL ACCESSORY

1X camera adapter	ISM-DL-CA1X
2X auxiliary objective	ISM-DL-OB2X
Auxiliary objective	see details

MEASURING SOFTWARE (INCLUDED)

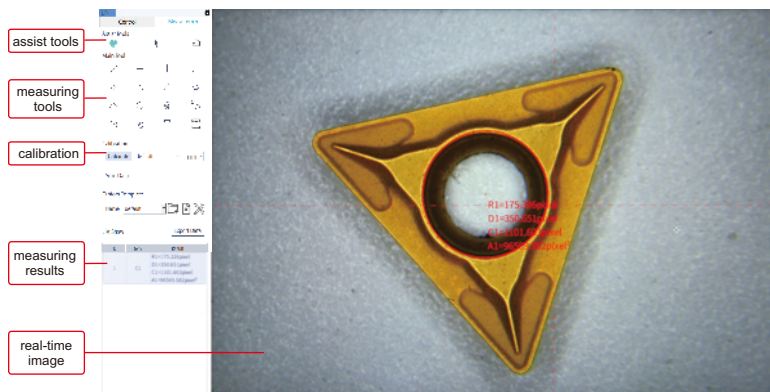

DIGITAL MEASURING MICROSCOPE (BASIC TYPE) CODE 5307-ID100A

ELECTRONIC MAGNIFICATION
FEEDBACK LENS

BUILT-IN SOFTWARE
WITHOUT COMPUTER

- Electronic magnification feedback lens: when the objective lens magnification is changed manually, the software automatically selects the corresponding pre-calibration data and calibration is not needed
- Two methods of LED brightness adjustment, knob adjustment and software adjustment
- Built-in software without computer, operated by mouse
- Take pictures, save to USB flash disk
- Measuring results can be sent to Excel

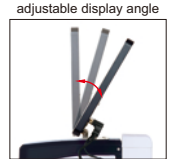

SPECIFICATION

Sensor	1/2" CMOS
Pixel	2M
Resolution	1920×1080
Magnification	12~77X
Focus distance	65mm
View field	3.2×1.8~20.9×11.7mm
Max workpiece height	60mm
Frame rate	60fps
Output	USB/HDMI
Power supply	power adapter
Dimension (L×W×H)	260×320×500mm
Weight	5.2kg

STANDARD DELIVERY

Main unit	1 pc
Calibration plate	1 pc
Power adapter	1 pc
Mouse	1 pc
16G USB flash disk	1 pc

MAGNIFICATION AND MEASURING ACCURACY

Objective magnification	Magnification	Measuring accuracy
0.7X	12X	±9μm
1X	17X	±9μm
1.5X	26X	±8μm
2X	35X	±7μm
2.5X	43X	±7μm
3X	51X	±7μm
3.5X	60X	±6μm
4X	68X	±6μm
4.5X	77X	±5μm

OPTIONAL ACCESSORY

0.5X auxiliary objective	5307-ID100A-OB05X
0.75X auxiliary objective	5307-ID100A-OB075X
2X auxiliary objective	5307-ID100A-OB2X

CUTTING TOOLS MICROSCOPE CODE ISM-CT820

TAKE PICTURES
AND VIDEOS

SPLIT SCREEN
DESIGN

BUILT-IN SOFTWARE
WITHOUT COMPUTER

- Split screen design, zoom in and out independently
- One mouse can operate two cameras
- Display cross hairs
- Brightness, contrast ratio, white balance are adjustable
- Basic measuring tools including point to point, point to line, line to line, angle, three-point circle, etc.

SPECIFICATION

Cutting tools range	Ø4~12mm, length 30-75mm
Lens	step-zoom lens
Output	HDMI
Resolution	1920×1080
Frame rate	60fps
Focus distance	85mm
View field	2×3.5~13.2×23.9mm
Magnification	20-132X
Power supply	AC 100-240V
Dimension (L×W×H)	450×300×700mm
Weight	20kg

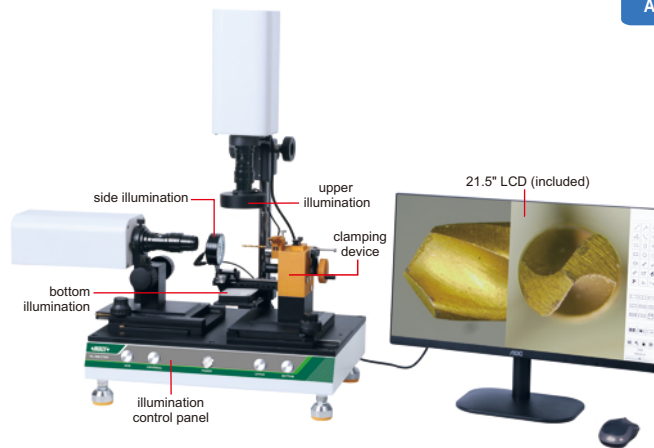

display cross hairs separately (movable)

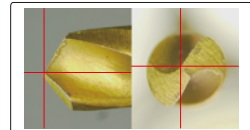

glass calibration plate (included)



screen display

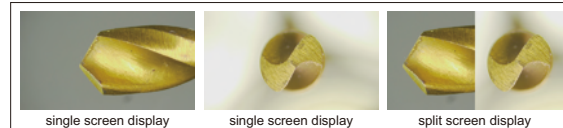

SOFTWARE (INCLUDED)

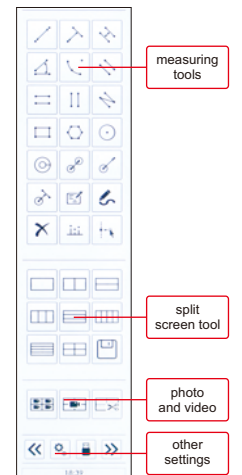

STANDARD DELIVERY

Main unit	1 pc
Display	1 pc
32G USB flash disk	1 pc
Mouse	1 pc
HDMI cable	1 pc
Glass calibration plate	1 pc
Anti-dust cover	1 pc

AUTO FOCUS DIGITAL MICROSCOPE (PROFESSIONAL TYPE) CODE 5319-AF290

- MOTORIZED ZOOM
- MOTORIZED LIGHT CONTROL
- NO CALIBRATION AFTER ZOOM
- AUTO FOCUS
- TAKE PICTURES AND VIDEOS
- MEASUREMENT

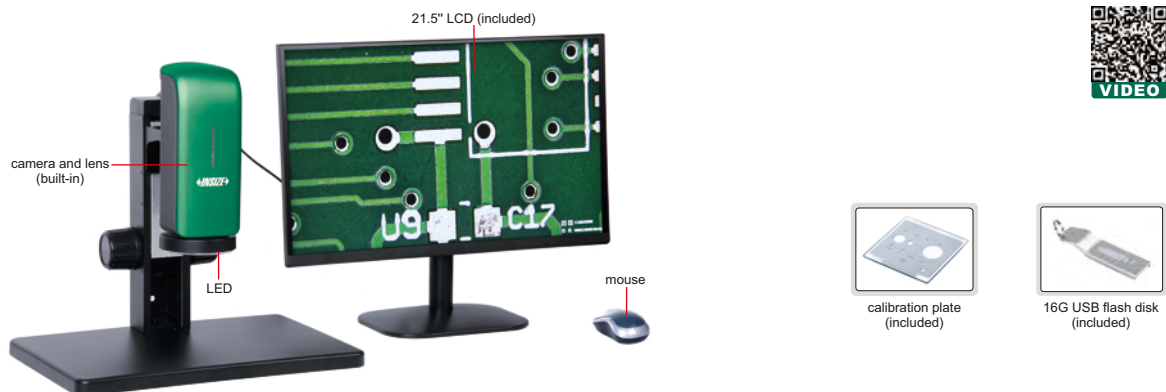

- Auto focus camera
- Take pictures and videos
- Built-in measuring software
- Automatic exposure and white balance
- Brightness, contrast ratio, gain are adjustable
- Display actual magnification
- Digital magnification
- Shortcut keyboard operation
- Display cross hair and gridline (blue/green/red/yellow/black/white colors)

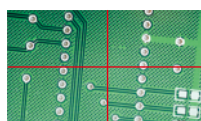

display cross hair and gridline (blue/green/red/yellow/black/white colors)

Shortcut keyboard function

- Take picture: take a picture and save it
- Video: record a video
- Freeze: the image can be frozen
- Manual focus-: reduce the manual focus value
- Manual focus+: increase the manual focus value
- Zoom+: increase the magnification
- Zoom-: reduce the magnification
- AF/MF: switch to auto focus or manual focus
- FBL: center the camera motor
- Mirror: image horizontal flipover
- Flip: image vertical flipover
- Focus: achieve one-key focus
- Zoom 1, 2, 3, 4: save the current magnification
- Brightness+: increase the brightness of the light
- Brightness-: reduce the brightness of the light



shortcut keyboard (included)

SPECIFICATION

Magnification	27.4X~163X
Sensor	1/2.8" CMOS
Pixel	2M
Measuring accuracy	±0.02mm
Resolution	1920×1080
Frame rate	50/60fps
Output	HDMI
Power supply	power adapter
Dimension (L×W×H)	600×280×390mm
Weight	6.5kg

STANDARD DELIVERY

Main unit (with stand)	1 pc
21.5" LCD	1 pc
16G USB flash disk	1 pc
Mouse	1 pc
HDMI cable	1 pc
Calibration plate	1 pc
White/black plate	1 pc
Shortcut keyboard	1 pc
Power adapter	2 pcs

FOCUS DISTANCE AND VIEW FIELD

Optical magnification*	0.8X	1X	2X	3X	4X	4.76X
Focus distance	88~133mm	88~133mm	98~123mm	103~115mm	108~111mm	108~111mm
View field (mm)	19.4×11~15.8×8.8	15×8.3~12.7×7.2	7.1×4~6.7×3.8	4.8×2.7~4.5×2.5	3.6×2~3.3×1.8	3×1.7~2.8×1.6

* The optical zoom lens can be arbitrarily zoomed between 0.8X and 4.76X

SOFTWARE (INCLUDED)

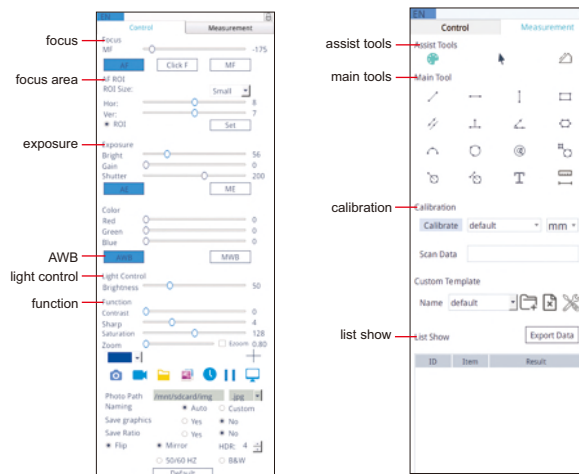

MINI DIGITAL MICROSCOPE (ECONOMIC TYPE) CODE 5311-M710

BUILT-IN LITHIUM BATTERY

TAKE PICTURES AND VIDEOS



8G memory card and holder (included)



infrared ray remote controller (included)

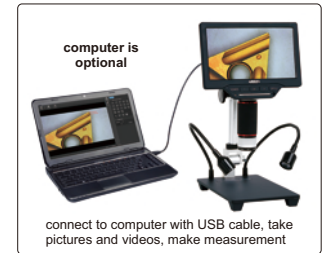
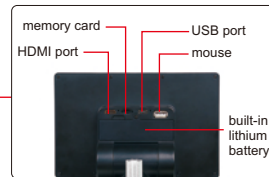

SPECIFICATION

Display resolution	1024×600
Sensor	1/3" CMOS
Sensor resolution	1280×960
Single pixel size	2μm×2μm
Frame rate	60fps/30fps
Magnification	1X~16X
White balance	auto/manual (10 levels RGB)/calibration
Exposure control	AE lock/exposure compensation (10 levels)
Image control	contrast/saturation/sharpness
Record media	memory card
Output	HDMI
Power supply	built-in lithium battery/power adapter
Dimension (L×W×H)	174×200×350mm
Weight	1.5kg

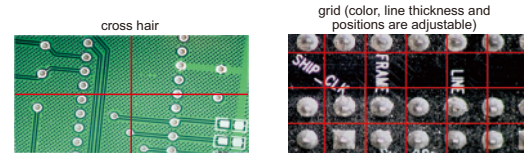

STANDARD DELIVERY

Main unit	1 pc
USB cable	1 pc
HDMI cable	1 pc
IR remote controller	1 pc
8G memory card and holder	1 pc
Plastic calibration rule	1 pc
Power adapter	1 pc

SOFTWARE FOR COMPUTER (included)

- Language: Chinese (Simplified), English
- Operation system: Windows 7/8/8.1/10 (64bit)
- Port: USB2.0 or above
- Measuring accuracy: 0.02mm

- | | | | |
|------------------------|------------------------------|----------------------------|---|
| point counting | center distance of 2 circles | straight line length | point-line distance |
| continuous line length | radius of a circle | distance between 2 lines | distance between parallel lines |
| area of a rectangle | cross line | radius of a 2-point circle | distance between line and first parallel line |
| area of a polygon | double cross line | radius of a 3-point circle | center distance of concentric circle |
| angle | arc | | |

Screen freezing:

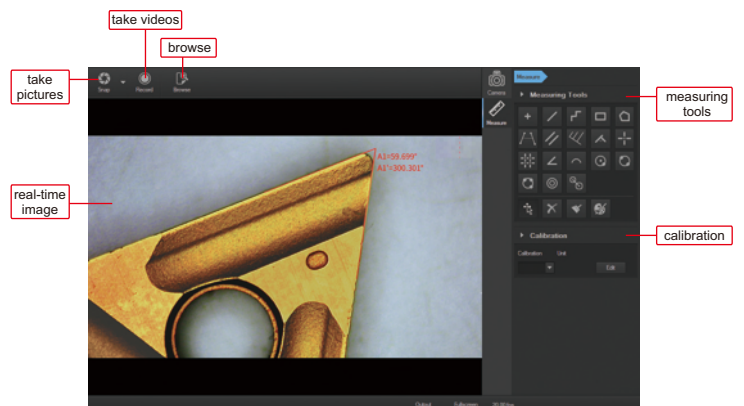
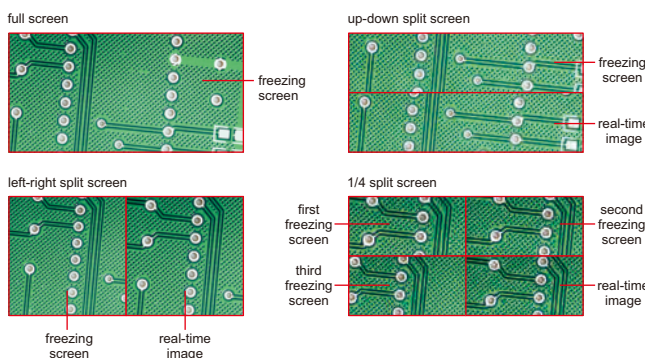

DIGITAL MEASURING MICROSCOPE

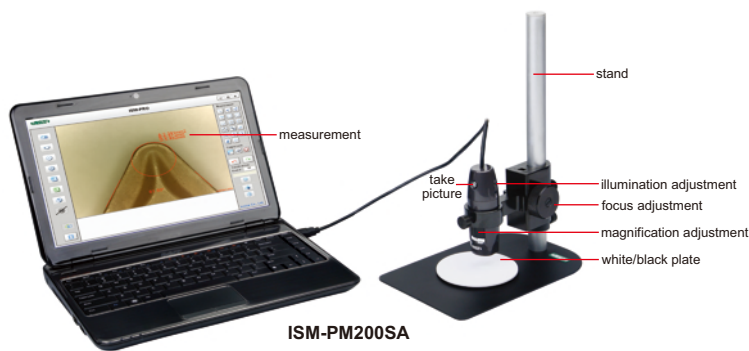

ISM-PM200SA
computer is optional

- Can take pictures and videos
- Supplied with software
- Calibration rules (graduation 0.1 and 1mm) are included
- With focus support

SPECIFICATION

Code	ISM-PM200SA
Magnification	10X~200X
Stand	standard
Pixel	2M (resolution: 1600×1200)
Illumination	built-in adjustable LED
Power supply	USB 2.0 cable (voltage required: 5±0.1V)



filter (optional)

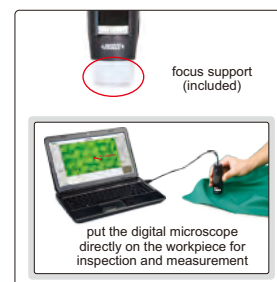

focus support (included)

put the digital microscope directly on the workpiece for inspection and measurement

MAGNIFICATION, FOCUS DISTANCE, VIEW FIELD AND ACCURACY

Magnification	Focus distance	View field (mm)	Accuracy
50X	21mm	8.1×6.4	30μm
100X	13mm	3.9×3.1	15μm
150X	16mm	2.6×2.1	10μm
200X	19mm	1.8×1.5	8μm

OPTIONAL ACCESSORY

Green filter	ISM-PM-GREEN
Yellow filter	ISM-PM-YELLOW
Blue filter	ISM-PM-BLUE

SOFTWARE

- **Language:** English, Japanese, Korean, German, Turkey, Portuguese, Chinese
- **Operation system:** Windows 7/8/XP/Vista
- **Measurement tools:**

- measure length of line or distance between two points
- measure distance between point and line
- measure distance between two parallel lines
- measure length of continuous line
- measure area of rectangle
- measure radius, girth and area of circle
- measure radius, length and angle of arc
- measure distance between two circles
- measure angle with three points
- measure angle with two lines
- add text
- add number with circle

■ Edge detection measurement tools:

- detect line automatically, and calculate length
- detect arc automatically, and calculate radius, angle and arc length
- detect two lines automatically, and calculate angle
- detect circle automatically, and calculate radius, girth and area
- detect two parallel lines automatically, and calculate distance

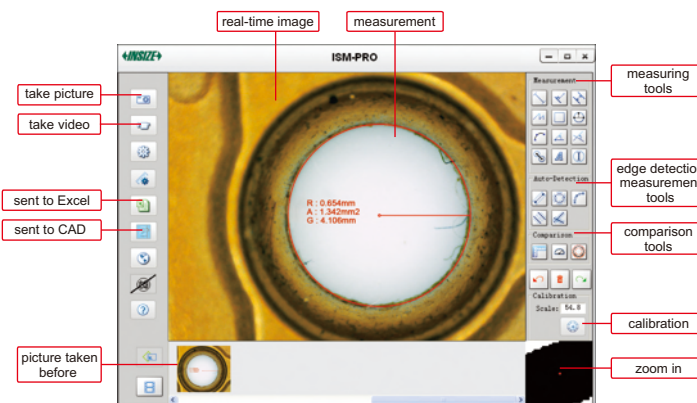

■ Comparison tools:

Create line, angle or circle with desired size, to compare with workpieces.

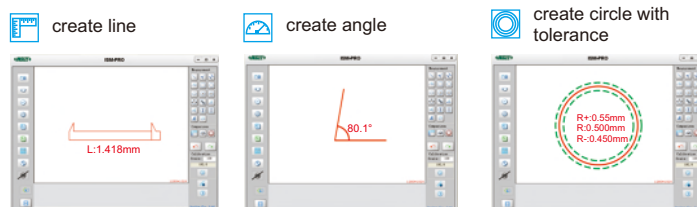

■ Data sent to CAD or Excel:

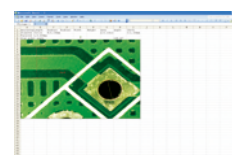
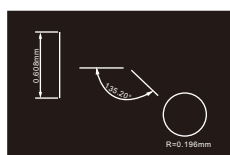

DIGITAL MEASURING MICROSCOPE CODE ISM-WF200



plastic calibration rule
(graduation 1mm, included)

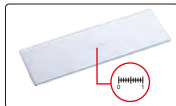

glass calibration rule
(graduation 0.1mm, included)



software flash disk
(included)

- Maximum working distance is 5m under WiFi mode
- Can be connected to multiple iPads, Android devices or computers at the same time under WiFi mode
- Take pictures and videos
- Supplied with software

SPECIFICATION

Magnification	10X~200X
Pixel	1.3M (resolution: 1280x1024)
Illumination	built-in adjustable LED
Power supply	built-in rechargeable battery

STANDARD DELIVERY

Microscope	1 pc
Focus support ring for 80X/150X	1 pc
Focus support ring for 60X/200X	1 pc
Glass calibration rule (graduation 0.1mm)	1 pc
Plastic calibration rule (graduation 1mm)	1 pc
Software and USB cable	1 pc
AC/DC adapter	1 pc

OPTIONAL ACCESSORY

Stand	ISM-PM-STAND
Green filter	ISM-PM-GREEN
Yellow filter	ISM-PM-YELLOW
Blue filter	ISM-PM-BLUE



stand (code
ISM-PM-STAND, optional)



filter (optional)



connected to iPad
by WiFi

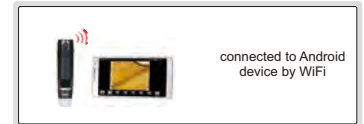

connected to Android
device by WiFi



connected to computer by WiFi



connected to computer by USB cable

MAGNIFICATION, FOCUS DISTANCE, VIEW FIELD AND ACCURACY

Magnification	Focus distance	View field	Accuracy
50X	21mm	8.1×6.4mm	30μm
100X	13mm	3.9×3.1mm	15μm
150X	16mm	2.6×2.1mm	10μm
200X	19mm	1.8×1.5mm	8μm

1 Software ISM-PAD (for iPad by WiFi)

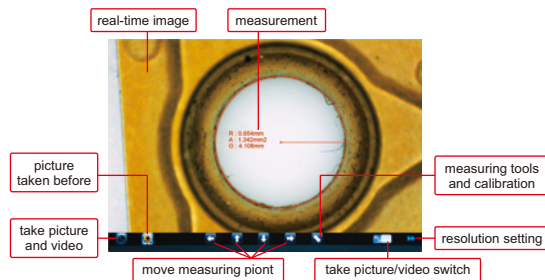

2 Software ISM-APK (for Android devices by WiFi)

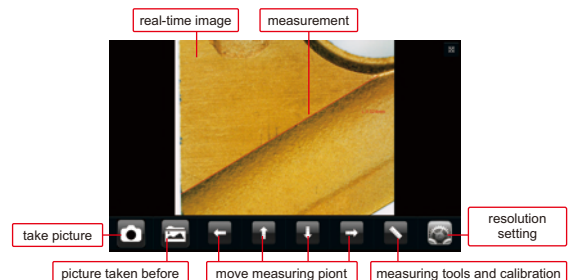

3 Software ISM-WF Partner (for computer by WiFi)

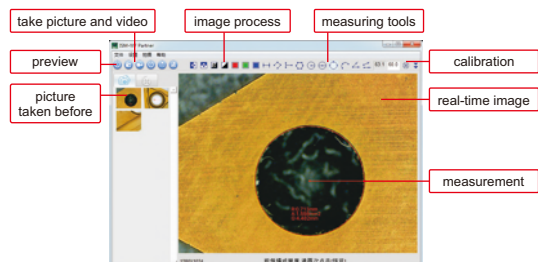

4 Software ISM-PRO (for computer by USB cable)

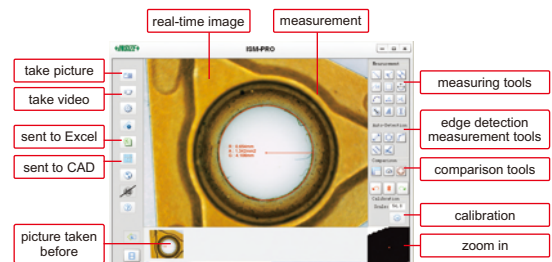

METALLURGICAL MICROSCOPES (PROFESSIONAL TYPE)

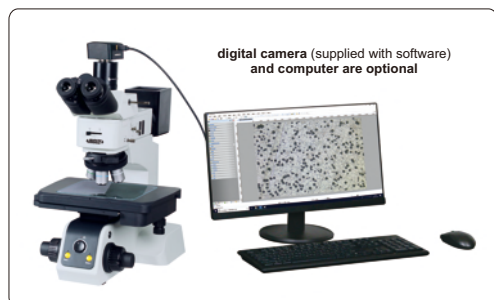

5108-M3000

- Infinite chromatic aberration correction optical system
- Three way observation tube with infinite hinge
- Translucent and reflective frame, front low-hand position coarse and fine coaxial focus adjustment mechanism, with adjustment elastic device to prevent sliding and random upper limit device
- Bright and dark field five-hole converter with DIC slot
- Adopt digital dimming, with light intensity reset and setting function
- With polarizer insert plate and 360° rotating analyzer insert slot

SPECIFICATION

Code	5108-M3000 (standard type)				5108-M3000H (high-definition type)			
Eyepiece	high eye point large field SWH10X-H (view field: Ø25mm, adjustable visibility)							
Objective (infinite long working distance bright and dark field semi achromatic)	5X	10X	20X	50X	5X	10X	20X	50X
Working distance	15mm	8.4mm	10.3mm	3.0mm	20mm	11mm	3.0mm	1.0mm
Numerical aperture	0.15	0.30	0.40	0.75	0.15	0.30	0.45	0.80
Optical magnification	50X~500X (up to 1000X with optional 100X objective)							
Digital magnification	170X~1700X (on 21.5" monitor), up to 3400X with optional 100X objective							
Stage	double layer size: 310×240mm travel: 150×100mm							
Condenser	roll-out achromatic condenser (numerical aperture 0.9)							
Illumination	5W LED, transmitted and reflected							
Observation tube	inverse image, distance adjustment: 50~76mm, two grade spectral ratio binocular: trinocular=100:0							
Diopter adjustment	±5 diopter (two eyepieces)							
Power supply	AC 100-240V							
Dimension (L×W×H)	310×600×500mm							
Weight	27kg							

OPTIONAL ACCESSORY

Camera and software	ISM-CM63
Glass calibration rule	ISM-MAS-SCALE
Computer	5108-M-COMPUTER
2.5X infinite long working distance bright field semi achromatic objective	5108-M-OB2D5X
100X infinite long working distance bright and dark field semi achromatic objective	5108-M-BD100X
50X infinite long working distance bright and dark field achromatic objective	5108-M-APO50X
100X infinite long working distance bright and dark field achromatic objective	5108-M-APO100X
Differential interference module (DIC)	5108-M-DIC

STANDARD DELIVERY

Main unit	1 pc
Anti-dust cover	1 pc
0.65X camera adapter (adjustable focus)	1 pc
Polarizer and analyzer	1 pc of each

METALLURGICAL MICROSCOPE



- Infinite optical system, polarization observation
- Kohler illumination system provides uniform illumination field
- Objectives 50X, 100X are spring type

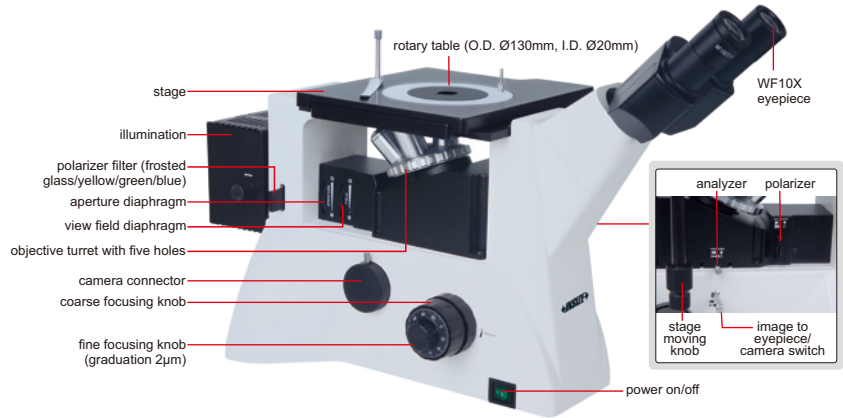

5103-M1000

SPECIFICATION

Code	5103-M1000 (bright field objectives)			
Illumination	6V/30W halogen lamp, brightness is adjustable			
Objective (infinite plan achromatic)	bright field objectives			
	10X	20X	50X	100X
Working distance	20.2mm	8.80mm	3.68mm	0.40mm
Numerical aperture	0.25	0.40	0.70	0.85
Magnification	100X~1000X			
Eyepiece (wide field)	10X (view field: Ø22mm)			
Stage	double layer			
	size: 242×200mm			
	travel: 30x30mm			
Pupil distance	53~75mm			
Diopter adjustment	±5 diopter (one eyepiece)			
Power supply	220V, 50/60Hz			
Dimension (L×W×H)	614×250×394mm			
Weight	13kg			

STANDARD DELIVERY

Main unit	1 pc
Polarizer and analyzer	1 pc of each
Anti-dust cover	1 pc

OPTIONAL ACCESSORY

Bright field objective	PL5X	5101-M-OB5X
	PL40X	5101-M-OB40X
	PL60X	5101-M-OB60X
	PL80X	5101-M-OB80X
10X dividing eyepiece (0.1mm/div.)		5103-M-EPD10X
Camera adapter *		5101-M-ADAPTER
Digital camera		ISM-CM63

*Digital camera must be used with camera adapter

ZOOM STEREO MICROSCOPE (ADVANCED TYPE)

LARGE ZOOM RATIO



SPECIFICATION

Code	ISM-ZS100T
Optical tube	trinocular
Eyepiece (wide field)	10X (view field: Ø23mm)
Objective	0.6X~5X (zoom)
Zoom ratio	1:8.3
Pupil distance	55~75mm
Diopter adjustment	±5 diopter (two eyepieces)
Working distance of objective	115mm
Max. workpiece height	75mm
Illumination	adjustable reflected and transmitted LED light
Power supply	110/220V, 50/60HZ
Dimension (L×W×H)	260×310×490mm
Weight	4.9kg

STANDARD DELIVERY

Main unit	1 pc
Digital camera adapter 0.55X	1 pc
WF10X eyepiece	2 pcs
Ø100mm glass plate	1 pc
Ø100mm white/black plate	1 pc
Anti-dust cover	1 pc

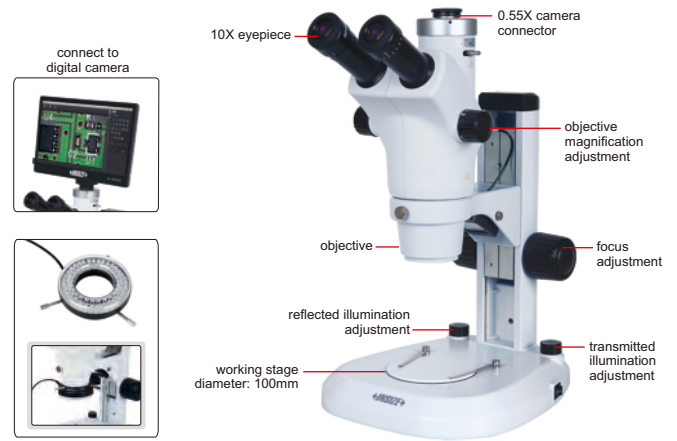

ISM-ZS100T

OPTIONAL ACCESSORY

Auxiliary objective	0.5X (focus distance: 220mm)	ISM-ZS100-OB05X *
	0.7X (focus distance: 125mm)	ISM-ZS100-OB07X
	2X (focus distance: 45mm)	ISM-ZS100-OB2X
Eyepiece	WF15X (view field: Ø16mm)	ISM-ZS100-EP15X
	WF20X (view field: Ø12mm)	ISM-ZS100-EP20X
	WF30X (view field: Ø8mm)	ISM-ZS100-EP30X
Sleeve for auxiliary objective		ISM-ZS200-ADAPTER
LED ring light		ISM-ZSRL
Digital camera adapter 1X		ISM-ZS100-DA
Digital camera		ISM-CM20, ISM-CM63, ISM-ZS70-S

*0.5X auxiliary objective must be used with ISM-ZS200-ADAPTER

ZOOM STEREO MICROSCOPE (STANDARD TYPE)



SPECIFICATION

Code	ISM-ZS50
Optical tube	binocular
Eyepiece (wide field)	10X (view field: Ø22mm)
Objective	0.8X~5X (zoom)
Zoom ratio	1:6.3
Pupil distance	55-75mm (adjustable)
Diopter adjustment	±5 diopter (two eyepieces)
Working distance of objective	115mm
Max. workpiece height	75mm
Illumination	adjustable reflected and transmitted LED light
Power supply	110/220V, 50/60Hz
Dimension (L×W×H)	290x260x480mm
Weight	4.9kg

STANDARD DELIVERY

Main unit	1 pc
WF10X eyepiece	2 pcs
Ø100mm glass plate	1 pc
Ø100mm white/black plate	1 pc
Anti-dust cover	1 pc

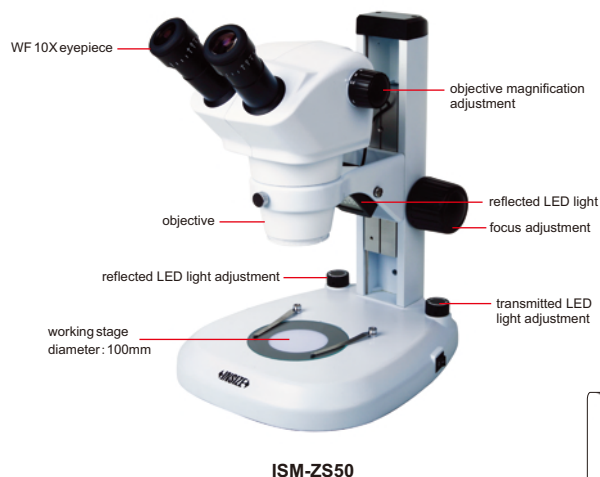

LED ring light (optional)

OPTIONAL ACCESSORY

Auxiliary objective	0.5X	ISM-ZS50-OB05X*
	2X	ISM-ZS50-OB2X
Eyepiece	10X dividing eyepiece (graduation 0.1mm/div.)	ISM-ZS50-EPD10X
	WF15X (view field: Ø16mm)	ISM-ZS50-EP15X
	WF20X (view field: Ø12mm)	ISM-ZS50-EP20X
LED ring light		ISM-ZS-RL
Sleeve for auxiliary objective		ISM-ZS30-ADAPTER

* 0.5X auxiliary objective must be used with ISM-ZS200-ADAPTER

ZOOM STEREO MICROSCOPE (WITH UNIVERSAL STAND)



SPECIFICATION

Code	5106-M50
Optical tube	binocular
Eyepiece (wide field)	10X (view field: Ø22mm)
Objective	0.8X~5X (zoom)
Zoom ratio	1:6.3
Pupil distance	55~75mm
Diopter adjustment	±5 diopter (two eyepieces)
Working distance of objective	115mm
Max. workpiece height	300mm
Illumination	adjustable reflected LED ring light
Power supply	power adapter
Dimension (L×W×H)	790×230×430mm
Weight	20kg

STANDARD DELIVERY

Main unit (with stand)	1 pc
WF10X eyepiece	2 pcs
LED ring light	1 pc
Anti-dust cover	1 pc

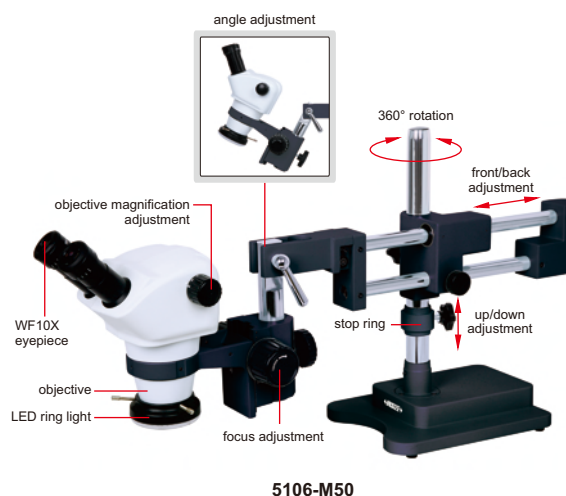

OPTIONAL ACCESSORY

Auxiliary objective	0.5X	ISM-ZS50-OB05X*
	2X	ISM-ZS50-OB2X
Eyepiece	10X dividing eyepiece (0.1mm/div.)	ISM-ZS50-EPD10X
	WF15X (view field: Ø16mm)	ISM-ZS50-EP15X
	WF20X (view field: Ø12mm)	ISM-ZS50-EP20X
Adapter sleeve		ISM-ZS30-ADAPTER

* 0.5X auxiliary objective must be used with ISM-ZS30-ADAPTER

ZOOM STEREO MICROSCOPE (BASIC TYPE) CODE ISM-ZS30



SPECIFICATION

Optical tube	binocular
Eyeiece (wide field)	10X (view field: Ø20mm)
Objective	1X~4.5X (zoom)
Zoom ratio	1:4.5
Pupil distance	55~75mm (adjustable)
Diopter adjustment	±5 diopter (two eyepieces)
Working distance of objective	97mm
Max. workpiece height	60mm
Illumination	adjustable reflected and transmitted LED light
Power supply	110/220V, 50/60Hz
Dimension (L×W×H)	260×190×400mm
Weight	4.3kg

STANDARD DELIVERY

Main unit	1 pc
WF10X eyepiece	2 pcs
Ø95mm glass plate	1 pc
Ø95mm white/black plate	1 pc
Anti-dust cover	1 pc



OPTIONAL ACCESSORY

Auxiliary objective	0.5X	ISM-ZS30-OB05X *
	0.63X	ISM-ZS30-OB06X *
	0.75X	ISM-ZS30-OB07X *
	2X	ISM-ZS30-OB2X
Eyepiece	10X dividing eyepiece (graduation 0.1mm/div.)	ISM-ZS30-EPD10X
	WF15X (view field: Ø16mm)	ISM-ZS50-EP15X
	WF20X (view field: Ø12mm)	ISM-ZS50-EP20X
LED ring light		ISM-ZS-RL
Sleeve for auxiliary objective		ISM-ZS30-ADAPTER
Digital camera		ISM-CM63
Camera adapter 0.75X **		ISM-AD-0D75

* 0.5X, 0.63X and 0.75X auxiliary objectives must be used with ISM-ZS30-ADAPTER
** Digital camera must be used with camera adapter 0.75X

LONG WORKING DISTANCE STEREO MICROSCOPES (LOW MAGNIFICATION)



SPECIFICATION

Code	5305-ZS80 (with metal base)	5305-ZS90 (with magnetic base)
Magnification	8X	
Eyeiece (wide field)	10X (view field: Ø20mm)	
Objective	0.8X	
Pupil distance	55~75mm	
Diopter adjustment	±5 diopter (one eyepiece)	
Working distance of objective	115mm	
Max. workpiece height	100mm	140mm
Dimension (L×W×H)	280x160x370mm	280x180x410mm
Weight	3.7kg	2.1kg

STANDARD DELIVERY

Main unit	1 pc
10X eyepieces	1 pair
0.8X objective	1 pc
Anti-dust cover	1 pc



OPTIONAL ACCESSORY

Eyepiece	WF5X (view field: Ø20mm)	5305-ZS80-EP5X
	WF15X (view field: Ø15mm)	5305-ZS80-EP15X
	WF20X (view field: Ø10mm)	5305-ZS80-EP20X
LED ring light		ISM-ZS-RL



PORTABLE MEASURING MICROSCOPE

SPECIFICATION

Code	ISM-PM100
Total magnification	100X
Eyeiece	10X with graduation
Objective (achromatic)	10X (numerical aperture: 0.25)
Working distance	7mm
Graduation	0.01mm
Viewing field	Ø1.8mm
Focus range	30mm
Illumination	LED light
Diameter of base	Ø63mm
Height	210mm
Weight	650g



ISM-PM100

STANDARD DELIVERY

Main unit	1 pc
Pen light	1 pc
Battery (AAA)	2 pcs

TABLE MAGNIFIER WITH ILLUMINATION CODE 7517-3D

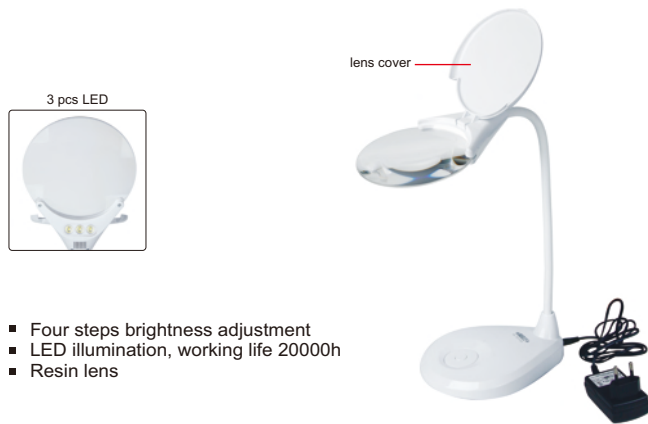

SPECIFICATION

Magnification	1.75X
Diopter	3D
Lens diameter	Ø125mm
Illumination	power: 3W, illuminance: 260lm
Power supply	power adapter 12V, 1A

TABLE MAGNIFIER WITH ILLUMINATION CODE 7516-5D

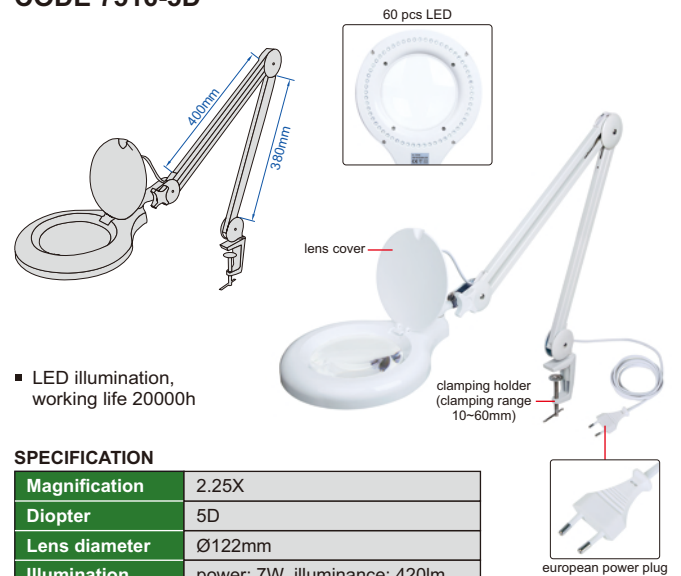

SPECIFICATION

Magnification	2.25X
Diopter	5D
Lens diameter	Ø122mm
Illumination	power: 7W, illuminance: 420lm
Power supply	100~240V, 50~60Hz

TABLE MAGNIFIERS WITH ILLUMINATION

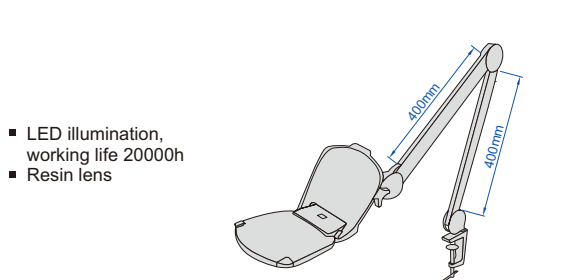

SPECIFICATION

Code	7520-320D	7521-3D
Magnification	two magnifications 1.75X/6X	1.75X
Diopter	3D/20D	3D
Lens diameter	160×127mm	Ø126mm
Illumination	power: 6W, illumination: 550lm	
Power supply	power adapter 12V, 1A	



7520-320D



7521-3D

DIGITAL MAGNIFIER CODE 7525-D4

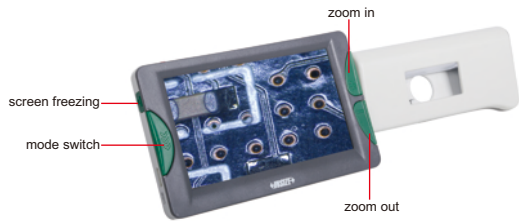

- 720P60 camera
- Auto focus
- With screen freezing function
- 26 color modes can be switched to meet the needs of different people
- Port to TV
- Automatic shutdown after 3 minutes



after the handle is folded, the magnifier can be directly placed on the object for observation

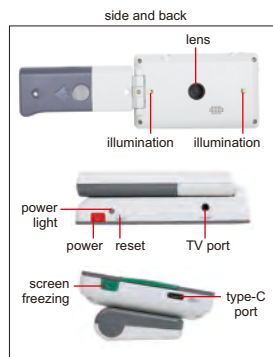

SPECIFICATION

Screen size	4.3 inch
Screen resolution	480x272
Magnification	2X-32X
Pixel	8M
Focus	manual/automatic
Color mode (26 modes)	color mode, color enhancement mode, negative mode, monochrome mode, black on white, white on black, blue on white, white on blue, yellow on black, black on yellow, yellow on blue, blue on yellow, green on white, white on green, orange on white, white on orange, red on black, black on red, orange on black, black on orange, yellow on green, green on yellow, red on white, white on red, yellow on white, white on yellow
Output	TV
Charging port	type-C
Lithium battery	1600mAH (for 4 hours working)
Dimension (LxWxH)	123x39x76mm (when the handle is folded)
Weight	210g

STANDARD DELIVERY

Main unit	1 pc
Video output cable	1 pc
USB charging cable	1 pc
Power adapter	1 pc

FOLDING MAGNIFIER

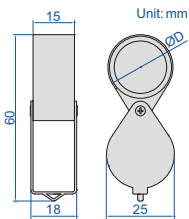

7511-8

closed



- Glass lens

Code	Magnification	Lens diameter (ØD)
7511-8	10X	Ø21mm

FOLDING MAGNIFIER WITH ILLUMINATION

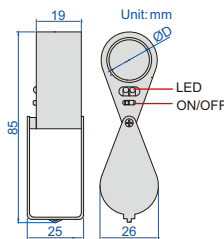

7515-10



2 pcs LED

closed



- Resin lens
- Powered by 3xLR927 batteries (included)

Code	Magnification	Lens diameter (ØD)
7515-10	10X	Ø21mm

FOLDING MAGNIFIER WITH ILLUMINATION

- Resin lens
- Powered by 2xCR1620 batteries (included)
- LED lights up automatically when opened



7514-1

Unit: mm

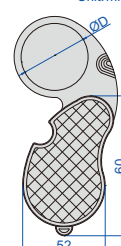

LED

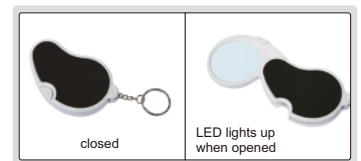

closed

LED lights up when opened

Code	Magnification	Lens diameter (ØD)
7514-1	2.5X	Ø45mm

MEASURING MAGNIFIERS (WITH ILLUMINATION)

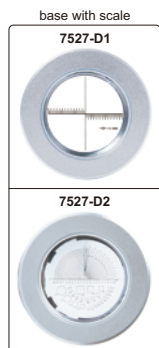

7527-D1

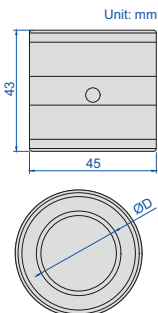

Unit: mm

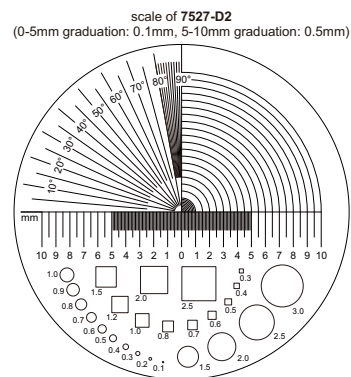
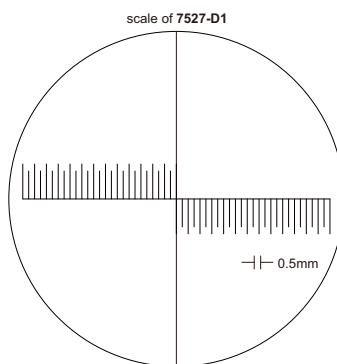

- Base with scale
- With 5 white LED and 5 UV LED
- Charging port: Type-C
- Work for 1.5h after fully charged

Code	Magnification	Lens diameter (ØD)
7527-D1	10X	Ø30mm
7527-D2	10X	Ø30mm

MAGNIFIER WITH ILLUMINATION

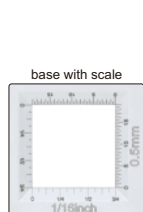

7524-10

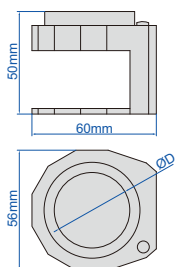

- Glass lens
- Powered by 3xAG7 batteries
- 3 pcs LED and 3 pcs UV
- Base with scale, graduation: 0.5mm, 1/16"

Code	Magnification	Lens diameter (ØD)
7524-10	10X	Ø30mm

MAGNIFIER WITH ILLUMINATION



7529-24

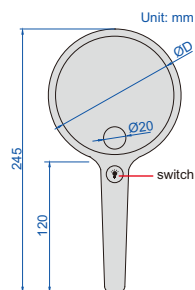

- Resin lens
- With 20 white LED, three levels brightness adjustment
- Charging port: Type-C

Code	Magnification	Lens diameter (ØD)
7529-24	2X/4X	Ø105mm

MAGNIFIER WITH ILLUMINATION



7528-3

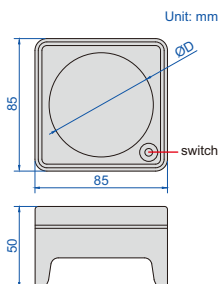

Unit: mm

- Glass lens
- With 4 white LED, three levels brightness adjustment
- Charging port: Type-C

Code	Magnification	Lens diameter (ØD)
7528-3	3X	Ø70mm

MAGNIFIERS WITH ILLUMINATION



7513-2

7513-4

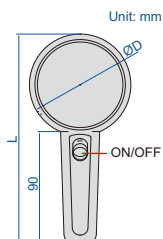

Unit: mm

- Glass lens
- Powered by 3xAAA batteries (included)

Code	Magnification	Lens diameter (ØD)	L
7513-2	2X	Ø75mm	170mm
7513-4	4X	Ø50mm	145mm



MAGNIFIER WITH TWO LENSES



- Resin lens
- Interchangeable lenses
- Powered by 3 pcs AAA batteries (included)

Code	Lens number	Magnification	Lens diameter (ØD)
7522-610	2 pcs	10X	37mm
		6X	50mm

MAGNIFIER

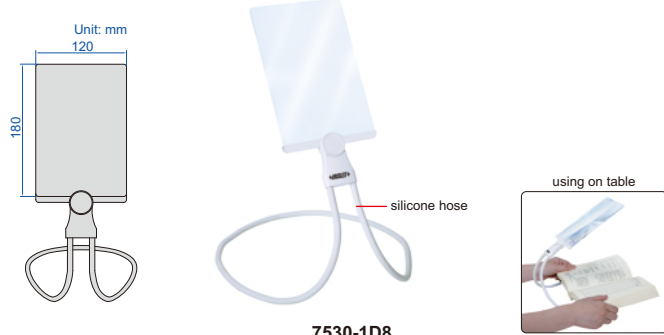

- Resin lens
- Silicone hose can be shaped according to needs
- Can be used on table or hanging around neck

Code	Magnification	Lens size
7530-1D8	1.8X	180x120mm

THREE WAYS MAGNIFIER WITH ILLUMINATION



- Resin lens
- Powered by 2xAAA batteries (included) or power adapter (110~240V, 50~60Hz)

Code	Magnification	Lens diameter (ØD/Ød)
7512-1	2X/4X	Ø120mm/Ø28mm



MAGNIFICATION GLASSES

- Resin lens
- Interchangeable lenses
- Powered by 3 pcs AAA batteries (included)



7523-3D5

Code	Lens number	Magnification
7523-3D5	5 pcs	1X
		1.5X
		2X
		2.5X
		3.5X

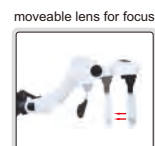
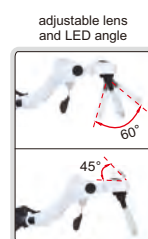

TELESCOPING INSPECTION MIRRORS

- Inspect hidden areas
- Rotation of the mirror: 360°
- Length of handle is adjustable, handle is made of stainless steel

Code	Size of mirror	Length
7160-1	Ø32mm	178~515mm
7160-2	50x90mm	330~490mm

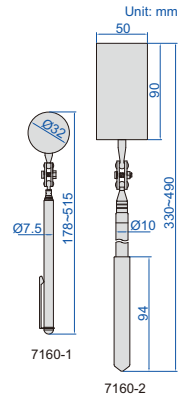
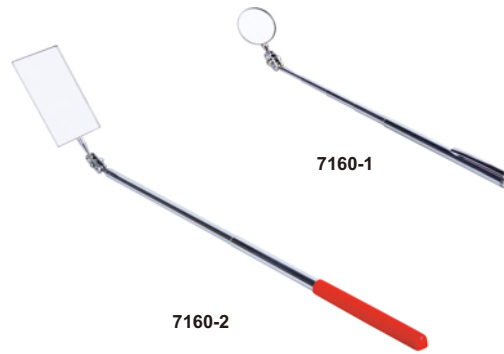

TELESCOPING INSPECTION MIRROR (WITH ILLUMINATION)

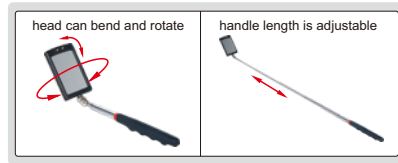

- Inspect hidden areas
- Head can bend and rotate
- Telescoping handle, made of stainless steel
- With two CR2032 batteries

Code	Size of mirror	Length
7162-1	65x42mm	285~875mm

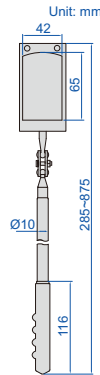

TELESCOPING MAGNETIC PICK-UP



7161-1

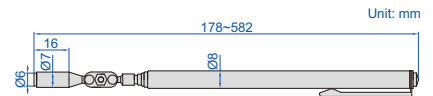

- Pick up metal parts from hidden areas
- Rotation of the magnetic head: 360°
- Length of handle is adjustable, handle is made of stainless steel

Code	Size of magnetic tip	Magnetic force	Length
7161-1	Ø6mm	0.45kgf	178~582mm

TELESCOPING MAGNETIC PICK-UP AND FLASHLIGHT



- Magnetic force of the head: 2kgf
- Magnetic force of the end: 4kgf
- For illumination and pick up steel parts in hidden areas
- Head can bend
- Telescoping handle, made of stainless steel
- Magnetic head and end
- With four LR44 batteries

Code	Flashlight range	Battery life	Length
7163-1	3m	8h	172~568mm

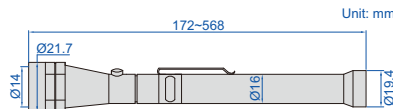

FLEXIBLE PICK-UP AND FLASHLIGHT

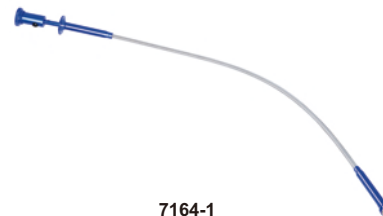

7164-1

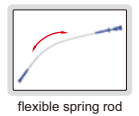
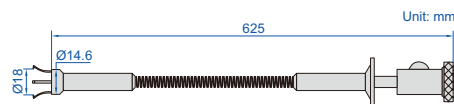

flexible spring rod



4 retractable claws



flashlight head



magnetic head

- For illumination and pick up steel parts in hidden areas
- Flexible spring rod, made of stainless steel
- Three LR44 batteries

Code	Magnetic force	Flashlight range	Battery life
7164-1	0.9kgf	1m	24h



VIDEOSCOPES

REAR FIBER ILLUMINATION

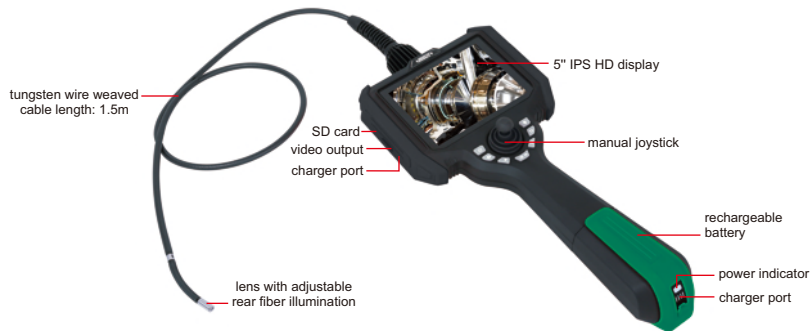

ISV-K6015

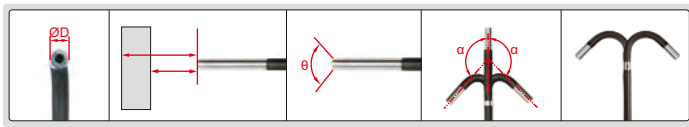

diameter (ØD) depth of field (DOF) angle of view (θ) bend range (α) bend

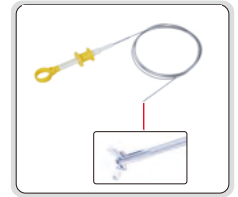

SPECIFICATION

Code		ISV-K1810	ISV-K2410	ISV-K2810	ISV-K3915	ISV-K6015
Lens	diameter (ØD)	1.8mm	2.4mm	2.8mm	3.9mm	6.0mm
	pixel	0.16M			0.92M	
	resolution	400×400			1280×720	
	depth of field	3-30mm	3-70mm	3-70mm	8-150mm	12-200mm
	bending direction	two directions	two directions	four directions	four directions	four directions
	bending range (α)	±160°				
	angle of view (θ)	120°				
	illumination	rear fiber				
	lens	sapphire glass lens				
	dust/waterproof	IP65			IP67	
Cable	bend control	manual joystick				
	length	1m	1m	1m	1.5m	1.5m
Main unit	type	tungsten wire weaved cable				
	display	5" high definition LCD				
	function	take pictures, take videos				
	file format	picture: JPG, video: MP4				
	image process	image zoom (1X, 2X, 3X, 4X)				
	image control	freeze, flip over, playback and analog ruler				
	memory	memory card				
	output	USB, HDMI				
power supply	rechargeable lithium battery (working time ≥ 4hours), AC/DC adapter (for continuous working)					
Weight	1000g					

STANDARD DELIVERY

Main unit	1 pc
32G SD card	1 pc
Card reader	1 pc
USB cable	1 pc
Tripod	1 pc
AC/DC adapter	1 pc

OPERATION ENVIRONMENT

Main unit	-10~50°C, no preheat
Operation temperature	-20~70°C
Storage temperature	-20~60°C
Relative humidity	maximum 90%, no condensation

OPTIONAL ACCESSORY

WiFi output	ISV-K-WIFI (must be installed in factory, only for Android OS)
Temperature alarm	ISV-K-HTALARM (must be installed in factory, for ISV-K3915 and ISV-K6015)
Hook	ISV-K-HOOK (must be installed in factory, for ISV-K3915 and ISV-K6015)
Magnet	ISV-K-MAGNET (must be installed in factory, for ISV-K3915 and ISV-K6015)
Clamp	ISV-K-CLAMP

MOBILE PHONE VIDEOSCOPE



■ For Android and IOS mobile phones

SPECIFICATION

Code	ISV-P6
Diameter of lens (ØD)	6±0.2mm
Length of cable	1m
Resolution	960×720, 1280×720 (switchable)
Depth of field	20mm~∞
Angle of view (θ)	100°
Bending range (α)	0~180°
Illumination	LED with 3 levels control
Cable type	wear resistant
Interface	USB, type-C
Mobile phone system	Android, IOS
Power supply	rechargeable battery (for 2 hours working)
Dimension (L×W×H)	195×57×105mm
Weight	450g

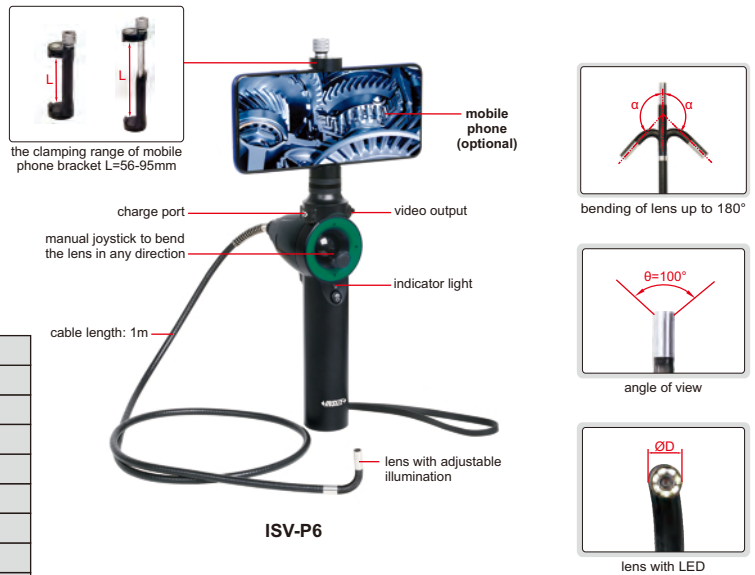

STANDARD DELIVERY

Main unit (with cable)	1 pc
Type-C cable	1 pc
Micro USB cable	1 pc
Iphone cable	1 pc
Charging cable	1 pc

VIDEOSCOPIES (BASIC TYPE)

TUNGSTEN WIRE WEAVED CABLE
BREAK AND WEAR RESISTANCE



SPECIFICATION

Code		ISV-T105	ISV-S106
Lens	diameter (ØD)	6mm	
	pixel	1M	
	resolution	1280×720	
	depth of field	20~150mm	
	bending direction	360°	
	bending range (α)	0°~220°	
	angle of view (θ)	120°	
	illumination	7 pcs LED, with 6 levels control	
	illuminance	25000Lux	
	lens	sapphire glass lens	
	dust/waterproof	IP67	
	bend control	manual joystick	
	temperature alarm	temperature sensor (optional)	
Cable	length	1m	1.5m
	type	tungsten wire weaved cable	
Main unit	display	3.5" IPS full-view display	
	display resolution	640×480	
	function	take pictures, take videos	
	file format	picture: JPG, video: MP4	
	image process	image zoom (1X, 2X, 3X, 4X, 5X)	
	memory	memory card (maximum: 64G)	
	output	USB, HDMI, WIFI (optional)	
	dust/waterproof	IP65	
power supply	rechargeable lithium battery (working time ≥ 3 hours; optional: additional battery, working time ≥ 9 hours) AC/DC adapter (for continuous working)		
Weight	1000g		

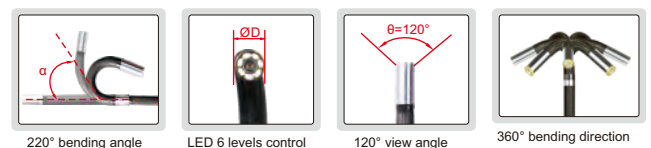

STANDARD DELIVERY

Main unit (with cable & lens)	1 pc
16G SD card	1 pc
Card reader	1 pc
USB cable	1 pc
Battery	1 pc
AC/DC adapter	1 pc

OPTIONAL ACCESSORY

Additional battery	ISV-S106-BATTERY (must be installed in factory)
WIFI output	ISV-S106-WIFI
Temperature alarm	ISV-S106-HT-ALARM

VIDEOSCOPE (BASIC TYPE)
CODE ISV-E40



MEMORY CABLE CAN BE FIXED AT ANY SHAPE

IP67
WATERPROOF

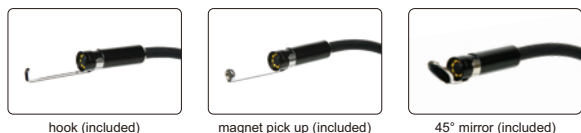

hook (included) magnet pick up (included) 45° mirror (included)

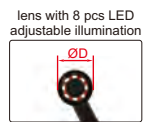

lens with 8 pcs LED adjustable illumination



memory cable

SPECIFICATION

Lens	diameter (ØD)	8mm
	pixel	0.92M
	resolution	1280x720
	depth of field	30~80mm
	angle of view	77°
	illumination	3 levels
	dust/waterproof	IP67
Cable	length	1180mm
	type	memory (can be set at any shape)
Main unit	display	5" IPS LCD
	function	take picture, take video
	file format	picture: JPG, video: MOV
	image process	image zoom (1.5X, 2X, 3X, 4X)
	memory	memory card (optional)
	output	type-C
	power supply	rechargeable lithium battery (for 5 hours working)
dimension	217×155×131mm	
Weight	506g	

STANDARD DELIVERY

Main unit	1 pc
45° mirror	1 pc
Hook	1 pc
Magnet pick up	1 pc

OPTIONAL ACCESSORY

32G memory card	ISV-E40-CARD
Card reader	ISV-E40-READER

OPERATION ENVIRONMENT

Operation temperature	-10~50°C
Storage temperature	-20~60°C
Operation humidity	15%~85%

VIDEOSCOPE (ECONOMIC TYPE)
CODE ISV-E30

MEMORY CABLE CAN BE FIXED AT ANY SHAPE

IP67
WATERPROOF

SPECIFICATION

Lens	diameter	5.2mm
	pixel	0.4M
	depth of field	30~80mm
	angle of view	72°
	illumination	8 levels
	dust/waterproof	IP67
	length	1m
Cable	type	memory (can be set at any shape)
	display	4.3" LCD
Main unit	function	take picture, take video
	file format	picture: JPG, video: AVI
	image zoom	2X
	memory card	memory card (optional)
	output	micro USB
	power supply	AA battery
	dimension	154×32.5×87.5mm
Weight	280g	

lens (adjustable illumination)

memory cable length: 1m



cable can be wrapped around the main unit



hook (included)



magnet pick up (included)

STANDARD DELIVERY

Main unit	1 pc
Hook	1 pc
Magnet pick up	1 pc
AA battery	4 pcs

OPTIONAL ACCESSORY

32G memory card	ISV-E40-CARD
Card reader	ISV-E40-READER

OPERATION ENVIRONMENT

Operation temperature	-10~50°C
Storage temperature	-20~60°C
Operation humidity	15%~85%



Coating Thickness Gages
Page 206-208



Surface Profile Gages
Page 209



Wet Film Gages
Page 209

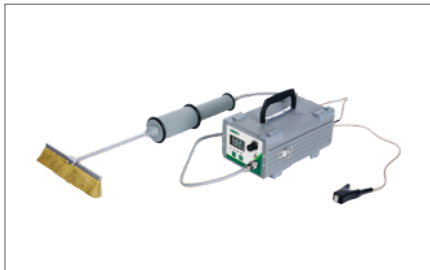

Holiday Detectors
Page 209



Gloss Meters
Page 210



Colorimeters
Page 210-211



Pencil Hardness Testers
Page 212



Cross Cut Adhesion Testers
Page 212



Digital Adhesion Testers
Page 213



Rotational Abrasion Testers
Page 213



Paint Film Flexibility Testers
Page 214



Impact Testers
Page 214

COATING THICKNESS GAGE (HIGH PRECISION) CODE ISO-8000FN

SUITABLE FOR THIN
COATING BELOW 10µm

FOR MAGNETIC AND
NON-MAGNETIC SUBSTRATES



calibration foils (included)



stand (optional)



eddy current probe N2000
(optional)



zero calibration plate
(included)



eddy current probe N1500
(optional)



magnetic induction
probe (included)

- Can measure thickness of thin coating below 10µm
- High repeatability
- Magnetic induction probe measures the thickness of non-magnetic coating and non-metallic coating on magnetic metal substrate
Substrate: iron, steel, magnetic stainless steel (not for non-magnetic stainless steel)
Coating: zinc, aluminum, copper, chrome, tin, plastic, powder, paint (not for nickel)
- Eddy current probe measures the thickness of non-conductive coating on non-magnetic metal substrate
Substrate: copper, aluminum, zinc, non-magnetic stainless steel
Coating: plastic, powder, paint, anodizing (not for chrome and zinc plating)
- Maximum, minimum, average and variance values can be calculated automatically

SPECIFICATION

Probe	magnetic induction probe (included)		eddy current probe (optional)*
Measuring range	0~500µm		0~1500µm 0~2000µm
Resolution	0.1µm (range<100µm) 1µm (100µm≤range≤500µm)		0.1µm (range<100µm) 1µm (100µm≤range<1000µm) 0.01mm (1.00mm≤range≤1.50mm) 0.1µm (range<100µm) 1µm (100µm≤range<1000µm) 0.01mm (1.00mm≤range≤2.00mm)
Accuracy	±(0.5+2%L)µm L is measuring thickness in µm		
Repeatability	≤(0.2+0.8%L)µm L is measuring thickness in µm		≤(0.2+1%L)µm L is measuring thickness in µm
Measuring mode	single and continuous		
Measure interval	single mode	1.5s	0.8s
	continuous mode	0.4s	0.4s
Calibration mode	zero calibration and multi-points calibration (1~5 points)		
Minimum substrate thickness	0.1mm		0.05mm
Minimum measuring area	Ø7mm		Ø25mm
Minimum radius of curvature workpieces	convex surface	1.5mm	
	concave surface	10mm	
Unit	µm/mil		
Power supply	4×1.5V AAA batteries		
Dimension	148×76×26mm		
Weight	148g		

STANDARD DELIVERY

Main unit	1 pc
Magnetic induction probe	1 pc
Zero calibration plate	1 pc
Calibration foils (5.6µm, 11.6µm, 24.6µm, 50.0µm, 100µm, 252µm, 390µm)	1 set
1.5V AAA battery	4 pcs

OPTIONAL ACCESSORY

Eddy current probe (with zero calibration plate)	ISO-8000FN-N1500*
	ISO-8000FN-N2000
Stand	ISO-8000FN-STAND

*For precision measurement of thin coating below 10µm, please use the stand for eddy current probe

COATING THICKNESS GAGE CODE 9501-1200

FOR MAGNETIC AND
NON-MAGNETIC SUBSTRATES

DATA
OUTPUT

POPULAR
MODEL

BLUETOOTH



- Magnetic induction probe (FE) measures the thickness of non-magnetic coating and non-metallic coating on magnetic metal substrate.
Substrate: iron, steel, magnetic stainless steel (not for non-magnetic stainless steel)
Coating: zinc, copper, chrome, tin, plastic, powder, paint (not for nickel)
- Eddy current probe (NFE) measures the thickness of non-conductive coating on non-magnetic metal substrate.
Substrate: copper, aluminum, zinc, non-magnetic stainless steel
Coating: plastic, powder, paint, anodizing (not for chrome and zinc plating)
- Tolerance measurement
- Data statistic, including average, variance, maximum and minimum values
- Data can be sent to Excel by connecting to computers via bluetooth or cable of receiver
- Support bluetooth printer
- Automatic power off



eddy current probe NFE (optional) with zero calibration block



magnetic induction probe FE90 for bores and grooves (optional)



calibration foils (included)



magnetic induction probe FE10 for large range (optional)



zero calibration block for FE (included)



receiver (optional)

SPECIFICATION

Probe type	FE (included) magnetic induction probe	NFE (optional) eddy current probe	FE90 (optional) magnetic induction probe for bores and grooves	FE10 (optional) magnetic induction probe for large range
Measuring range	0~1250μm	0~1250μm	0~1250μm	500~10000μm
Accuracy	$\pm(3\%L+1)\mu\text{m}$ (range $\leq 1250\mu\text{m}$) $\pm(3\%L+10)\mu\text{m}$ (range $> 1250\mu\text{m}$) L is measuring thickness in μm			
Resolution	0.1μm (range $< 100\mu\text{m}$) 1μm (range $\geq 100\mu\text{m}$)			
Measuring mode	continuous and single			
Minimum substrate thickness	0.5mm	0.3mm	0.5mm	2mm
Minimum measuring area	Ø7mm	Ø5mm	Ø7mm	Ø40mm
Minimum curvature radius of convex workpiece	1.5mm	3mm	—	10mm
Memory	600			
Output	USB			
Power supply	2×1.5V AA batteries			
Dimension	135×77×32mm			
Weight	172g			

STANDARD DELIVERY

Main unit	1 pc
Magnetic induction probe (FE)	1 pc
Zero calibration block for FE probe	1 pc
Calibration foils (50/100/250/500/1000μm)	1 set
1.5V AA battery	2 pcs
Software and USB cable	1 pc

OPTIONAL ACCESSORY

Receiver	ISR-C300-RECEIVER
Cable of receiver	9501-1200-CABLE
Bluetooth printer	ISR-C002-PRINTER
Eddy current probe (NFE) with zero calibration block	9501-1200-NFE
Magnetic induction probe (FE90) for bores and grooves	9501-1200-FE90
Magnetic induction probe (FE10) for large range	9501-1200-FE10

COATING THICKNESS GAGE (BASIC TYPE) CODE ISO-1200FN

FOR MAGNETIC AND
NON-MAGNETIC SUBSTRATES

- Probe is suitable for both magnetic and non-magnetic metal substrates
- Can measure the thickness of non-magnetic coating and non-metallic coating on magnetic metal substrate
Substrate: iron, steel, magnetic stainless steel (not for non-magnetic stainless steel)
Coating: zinc, aluminum, copper, chrome, tin, plastic, powder, paint (not for nickel)
- Can measure the thickness of non-conductive coating on non-magnetic metal substrate
Substrate: copper, aluminum, zinc, non-magnetic stainless steel
Coating: plastic, powder, paint, anodizing (not for chrome and zinc plating)
- 3 measuring modes: Fe, NFe, Fe/NFe
- Store 9 measuring records
- Small and portable, easy for operation

SPECIFICATION

Measuring range	0~2000µm	
Resolution	0.1µm (range<100µm)	
	1µm (100µm≤range<1000µm)	
	0.01mm (1mm≤range≤2mm)	
Accuracy	±(2µm+3%L) L is measuring thickness in µm	
Measure interval	0.5s	
Calibration mode	zero calibration	
Measuring mode	Fe, NFe, Fe/NFe	
Minimum substrate thickness	Fe	0.2mm
	NFe	0.05mm
Minimum measuring area	Ø25mm	
Minimum radius of curvature workpieces	convex surface	5mm
	concave surface	25mm
Unit	µm/mil	
Power supply	2×1.5V AAA batteries	
Main unit dimension	101×62×28mm	
Probe dimension	71×26×22mm	
Weight	114g	

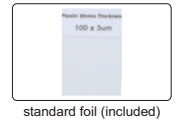
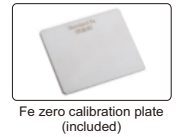

STANDARD DELIVERY

Main unit	1 pc
Fe zero calibration plate	1 pc
NFe zero calibration plate	1 pc
Standard foil (100µm)	1 pc
1.5V AAA battery	2 pcs

COATING THICKNESS GAGE (BASIC TYPE) CODE ISO-1000FN

FOR MAGNETIC AND
NON-MAGNETIC SUBSTRATES

- Probe is suitable for both magnetic and non-magnetic metal substrates
- Can measure the thickness of non-magnetic coating and non-metallic coating on magnetic metal substrate
Substrate: iron, steel, magnetic stainless steel (not for non-magnetic stainless steel)
Coating: zinc, aluminum, copper, chrome, tin, plastic, powder, paint (not for nickel)
- Can measure the thickness of non-conductive coating on non-magnetic metal substrate
Substrate: copper, aluminum, zinc, non-magnetic stainless steel
Coating: plastic, powder, paint, anodizing (not for chrome and zinc plating)
- 3 measuring modes: Fe, NFe, Fe/NFe
- Store 9 measuring records
- Small and portable, easy for operation

SPECIFICATION

Measuring range	0~2000µm	
Resolution	0.1µm (range<100µm)	
	1µm (100µm≤range<1000µm)	
	0.01mm (1mm≤range≤2mm)	
Accuracy	±(2µm+3%L) L is measuring thickness in µm	
Measure interval	0.5s	
Calibration mode	zero calibration	
Measuring mode	Fe, NFe, Fe/NFe	
Minimum substrate thickness	Fe	0.2mm
	NFe	0.05mm
Minimum measuring area	Ø25mm	
Minimum radius of curvature workpieces	convex surface	5mm
	concave surface	25mm
Unit	µm/mil	
Power supply	2×1.5V AAA batteries	
Dimension	101×62×28mm	
Weight	79g	

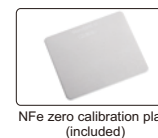

STANDARD DELIVERY

Main unit	1 pc
Fe zero calibration plate	1 pc
NFe zero calibration plate	1 pc
Standard foil (100µm)	1 pc
1.5V AAA battery	2 pcs

SURFACE PROFILE GAGE

measure peak-to-valley height of blast cleaned surface

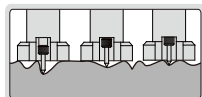

- Measure peak-to-valley height of blast cleaned surface. If the profile is too low, the adhesion of the coating to the surface will be reduced. If the profile is too high, there is the danger that the profile peaks will remain uncoated, allowing rust spots to occur.
- Meet ASTM D 4417-B
- Zero set block is included, set zero before measurement
- Stainless steel base



2344-1

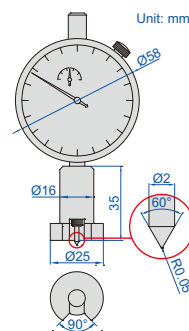

Code	Range	Dial indicator stroke	Dial indicator graduation	Accuracy
2344-1	0-1mm	1mm	0.001mm	$\pm 0.005\text{mm}$

WET FILM GAGES



4845-1

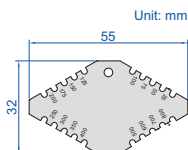

4845-1



4845-2

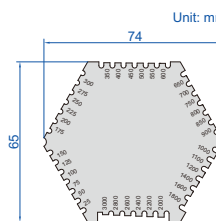

4845-2

- Made of stainless steel

Code	Range	Accuracy	Thickness
4845-1	25-800 μm	$\pm 5\mu\text{m}$	1.8mm
4845-2	25-3000 μm	25-100 μm : $\pm 5\mu\text{m}$ 100 μm -3000 μm : $\pm 5\%$	1mm

HOLIDAY DETECTOR CODE 9511-HA30



- Inspect anti-corrosion coating status of different thickness with adjustable pulse high-voltage, coating includes insulating paint, glass lining, rubber lining, glass fiber reinforced plastic, coal tar epoxy, etc
- When the brush with pulse high-voltage moves near the crack, pinhole or thin area on the coating surface, which results in gap gas breakdown and discharge spark, sound and light alarm will appear on the probe and the alarm sound can be heard with the headphone
- LCD display with light-control backlight
- Built-in rechargeable battery, easy to carry and suitable for outdoor inspection
- Automatic power off



strip brush (included)

SPECIFICATION

Measuring range	0.05~10mm (customization for inspecting coating thicker than 10mm is available)
Output voltage	0.6~30.0kV (stepless adjustable)
Resolution	0.1kV
Power	$\leq 5\text{W}$
Power supply	12V rechargeable Ni-MH battery
Dimension	220×130×88mm
Weight	2.5kg

STANDARD DELIVERY

Main unit	1 pc
Probe	1 pc
Strip brush*	1 pc
Flat brush	1 pc
Ground wire	1 pc
Ground rod	1 pc
Headphone	1 pc
AC/DC adapter	1 pc

* Arc brush and circular probe can be customized



headphone (included)



flat brush (included)

60° GLOSS METER (BASIC TYPE) CODE 5702-DG6



base with calibration block (included)

SPECIFICATION

Incidence angle	60°
Measuring range	0~200GU
Resolution	0.1GU
Accuracy	±1.5GU (range<120GU) ±1.5% (range≥120GU)
Repeatability	0.2GU (range<120GU) 0.2% (range≥120GU)
Zero error	0.1GU
Measuring area	20×10mm
Power supply	rechargeable battery
Data port	USB
Dimension	135×45×75mm
Weight	237g

STANDARD DELIVERY

Main unit	1 pc
Base with calibration block	1 pc
U disk	1 pc
AC/DC adapter	1 pc
USB data cable	1 pc
Cleaning cloth	1 pc

- To test the gloss of coating, such as painting, varnish, printing ink, etc.
- To test the material surfaces, such as metal, granite, ceramic, plastic, paper, etc.
- According to ISO 2813, ISO 7668, ASTM D523, ASTM D2457, DIN 67530
- Automatic judgement after setting high and low limits
- Automatic power off

software (included), test can be controlled from the software, display test data and report

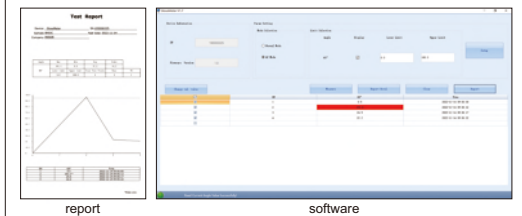

report

software

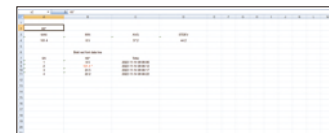

measurement data is sent to Excel

60° GLOSS METER CODE ISQ-DG6



base with calibration block (included)



connect mobile phone via bluetooth (only Android system)

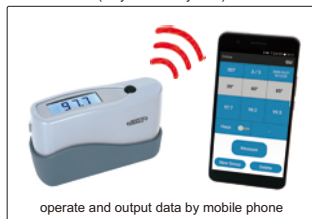

operate and output data by mobile phone

- To test the gloss of coating, such as painting, varnish, printing ink, etc.
- To test the material surfaces, such as metal, granite, ceramic, plastic, paper, etc.
- According to ISO 2813, ASTM D2457, ASTM D523
- Automatic power off

SPECIFICATION

Incidence angle	60°
Measuring range	0~150GU
Resolution	0.1GU
Accuracy	±1.2GU
Repeatability	0.4GU
Zero set error	0.2GU
Measuring area	20×10mm
Output	bluetooth
Power supply	1×1.5V AA battery
Dimension	123×38×65mm
Weight	300g

STANDARD DELIVERY

Main unit	1 pc
Base with calibration block	1 pc
Spare calibration block	1 pc

COLORIMETER (BASIC TYPE) CODE 5700-LS35



- Conforms with CIE 15, CIE S 005, ISO 7724-1 and ISO 13655 standards
- 3.5-inch IPS display and capacity touch panel
- Contains multiple color cards and can match the closest color code quickly
- QC testing function, can set color difference threshold
- Able to store 1000 colors and 1000 color comparison
- 3.7V/4000mAh battery, 10000 continuous measurements

SPECIFICATION

Illumination geometry	D/8, specular component include (SCI)
Illumination light source	full spectrum LED light source
Measurement conditions	light source D65, field of view 10°
Measuring time	about 1s
Color space	CIE Lab, Luv, LCh, Yxy, CMYK, RGB, He
Color difference formula	ΔE^*ab , ΔE^*uv , ΔE^*94 , ΔE^*cmc (2:1), ΔE^*cmc (1:1), ΔE^*00
Repeatability	standard deviation ΔE^*ab is within 0.03 (measurement condition: the average value of 30 measurements on the whiteboard at an interval of 3s after calibration)
Charging interface	USB (type-C)
Dimension	86×63×158mm
Weight	245g

STANDARD DELIVERY

Main unit	1 pc
White calibration cavity	1 pc
USB cable	1 pc
AC/DC adapter	1 pc
Cleaning cloth	1 pc
Locating plate	1 pc



white calibration cavity (included)

SPECTROPHOTOMETER CODE 5701-D40

THREE KINDS
OF APERTURE

MATCHING COLOR
CARD QUICKLY

GRATING
SPECTROPHOTOMETRIC

DATA
OUTPUT

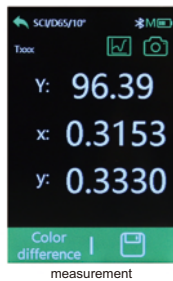
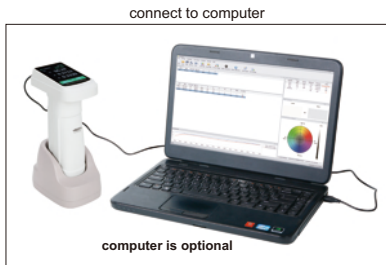

- Conforms with CIE No.15, ISO7724-1, ASTM E1164 and DIN5033 Teil7 standards
- Grating spectrophotometric, 3.5" IPS full color screen, dual optical path high precise CMOS array sensor
- Use long life and low power consumption combined LED light source, include UV and exclude UV measurement
- Camera locating function, switchable 11mm/6mm/1×3mm aperture
- Large capacity storage space, over 20,000 measurement data
- Two standard observer angles, a variety of illuminant, a variety of color indexes, conforms with a variety of standard colorimetric data
- Measure sample spectra, accurate Lab data, can be used in color matching and accurate color transmission

SPECIFICATION

Optical geometry	D/8 (diffused illumination/8° direction reception) SCI+SCE (specular component included+specular component excluded)	
Integrating sphere size	Ø40mm	
Light source	LED (full band balanced LED)+UV	
Spectrophotometric mode	grating	
Sensor	dual optical path high precise CMOS array sensor	
Wavelength range	400~700nm	
Wavelength interval	10nm	
Reflectance measurement range	0~200%	
Reflectance resolution	0.01%	
Display resolution	0.01	
Illumination area/Aperture	MAV: Ø11mm; SAV: Ø6mm; MINI: 1×3mm	
Color space	CIE-Lab, CIE-LCh, HunterLab, CIE Luv, XYZ, Yxy, RGB	
Color difference formula	ΔE^*ab , ΔE^*cmc , ΔE^*94 , ΔE^*00	
Other colorimetric index	whiteness (ASTM E313-00, ASTM E313-73, CIE/ISO, AATCC, Hunter, Taube Berger Stensby), Yellowness (ASTM D1925, ASTM 313-00, ASTM E313-73), Blackness (My, dM), Color fastness, Tint (ASTM E313-73) Color density CMYK (A, T, E, M), Milm, Munsell, Opacity, Color strength	
Observer angle	2°/10°	
Illuminant	A, B, C, D50, D55, D65, D75, F1, F2, F3, F4, F5, F6, F7, F8, F9, F10, F11, F12, CWF, U30, U35, DLF, NBF, T183, T184, Id50, Id65, LED-B1, LED-B2, LED-B3, LED-B4, LED-B5, LED-BH1, LED-RGB1, LED-V1, LED-V2	
Measuring time	about 1.5s	
Repeatability	spectral reflectance	within 0.08% of standard deviation
	colorimetric values	$\Delta E^*ab \leq 0.025$ (after whiteboard correction, measuring the whiteboard 30 times at 5s interval)
Inter-instrument error	$\Delta E^*ab \leq 0.25$ (BCRA series II, average value of 12 color plates)	
Output	USB, Bluetooth	
Light source lifetime	10 years, more than 1 million times measurements	
Battery	3.7V/3000mAh, rechargeable 8000 times continuous tests	
Dimension	95×129×231mm	
Weight	750g	

software (included), test can be controlled from the software, display test data, report



text report

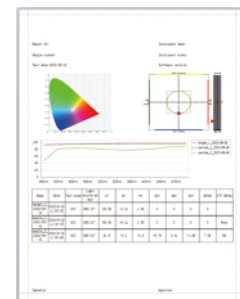

graphic report

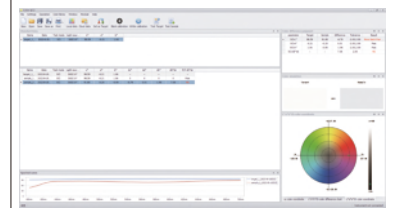

software

STANDARD DELIVERY

Main unit	1 pc
White calibration cavity	1 pc
Measuring aperture	3 pcs
USB cable	1 pc
USB disk	1 pc
AC/DC adapter	1 pc

PENCIL HARDNESS TESTER CODE PHT-C751



- For flat coating surfaces
- Conform to ASTM D3363, ISO 15184, BS3900-E19 and ECCA-T4/1



SPECIFICATION

Pressure of pencil on coating	500g, 750g, 1000g (main unit is 500g, one weight is 750g, two weights are 1000g)
Angle between pencil and measured surface	45°
Dimension (L×W×H)	95×80×110mm
Weight	2kg

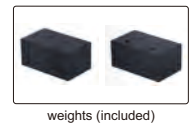
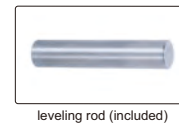

STANDARD DELIVERY

Main unit	1 pc
Weights	2 pcs
Leveling rod	1 pc
Level	1 pc
Pencil	12 pcs (4B, 3B, 2B, B, HB, F, H, 2H, 3H, 4H, 5H, 6H)
Pencil sharpener	1 pc

OPTIONAL ACCESSORY

Pencil (12 pcs: 4B-6H)	PHT-C751-P
400 grade abrasive paper	PHT-C751-S

CROSS CUT ADHESION TESTER CODE ISQ-PK100



- To test the adhesion of paint coating on metal, wood, plastic, etc.
- According to ISO 2409, ASTM D3359, DIN53151

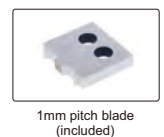
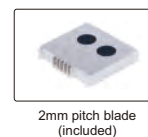
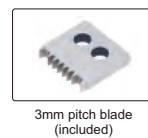
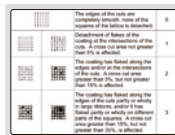

SPECIFICATION

Blade		1mm pitch	2mm pitch	3mm pitch
Applied paint thickness	on hard substrate (like metal)	0~60μm	61~120μm	121~250μm
	on soft substrate (like wood, plaster)	-	0~120μm	121~250μm
Minimum substrate thickness	hard substrate (like metal)	0.25mm	0.25mm	0.25mm
	soft substrate (like wood, plaster)	-	10mm	10mm
Minimum size of test sample		150×100mm	150×100mm	150×100mm
Dimension		170×28×40mm		
Weight		430g		

STANDARD DELIVERY

Handle	1 pc
1mm pitch blade	1 pc
2mm pitch blade	1 pc
3mm pitch blade	1 pc
Test tape (ISQ-PK100-1)	1 pc
2X magnifier	1 pc
Brush	1 pc

DIGITAL ADHESION TESTER CODE SPT-AD21

- Pull-off test
- Built-in rechargeable lithium battery, no need external power source
- Portable design, can be used anywhere
- Standard USB interface, can directly transmit the stored data to computer, no need to install software
- Conforms to GB/T 5210, ASTM D4541/D7234, ISO 4624/16276-1
- Store all test results, includes maximum pull-off force, pull-off rate, dolly size and time
- Built in real-time clock, all saved data have corresponding date and time
- Selectable four different sizes dolly for different resolution and testing range
- No need conversion, the instrument can calculate pull-off force according to the dolly size
- Get the testing results from LCD directly
- Two units MPa and psi for selection and can be converted automatically



SPECIFICATION

Range	0~20MPa
Dolly diameter	Ø20mm
Resolution	0.01MPa (1psi)
Accuracy	±1% full scale
Pull-off force	0.7~20MPa
Power	built-in rechargeable lithium battery
Dimension (LxWxH)	360x75x115mm
Weight	3kg

STANDARD DELIVERY

Main unit	1 pc
Ø20mm dolly	20 pcs
Cutting tool	1 pc
Charger	1 pc
USB cable	1 pc
Glue gun	1 pc
3M glue	1 pc



cutting tool (included) for Ø10mm, Ø14mm, Ø20mm dolly



Ø20mm dolly (included)



glue gun and glue (included)

OPTIONAL ACCESSORY

Ø10mm dolly	SPT-AD21-10	10 pcs/package pull-off force: 2.8~80MPa
Ø14mm dolly	SPT-AD21-14	10 pcs/package pull-off force: 1.4~40MPa
Ø20mm dolly	SPT-AD21-20	10 pcs/package pull-off force: 0.7~20MPa
Ø50mm dolly	SPT-AD21-50*	10 pcs/package pull-off force: 0.4~3.5MPa
Cutting tool	SPT-AD21-CUTTER1	for Ø10mm, Ø14mm, Ø20mm dolly
Cutting tool	SPT-AD21-CUTTER2*	for Ø50mm dolly
Sleeve	SPT-AD21-SLEEVE*	for Ø50mm dolly
Glue	SPT-AD21-GLUE	3M DP420 epoxy glue/50ml

*Ø50mm dolly requires corresponding cutter and sleeve

ROTATIONAL ABRASION TESTER CODE QMY-AP32



- To test flat paint film
- Comply with ISO 7784-2, ISO 9352, GB/T1768, ASTM D3884, ASTM D1175 standards



STANDARD DELIVERY

Main unit	1 pc
Vacuum cleaner	1 pc
1000g weight	2 pcs
750g weight	2 pcs
500g weight	2 pcs
TABER CS-10 grinding wheel	1 pair
Sandpaper	10 pcs
Glass plate	5 pcs

SPECIFICATION

Platform rotary speed	60±2 r/min, 72±2 r/min (selectable)
Load weight	500g, 750g, 1000g
Sample size	Ø100mm
Grinding wheel	external diameter (51.6±0.1)mm, thickness (12.7±0.1)mm
Counting range of platform rotation	0~9999 times
Motor power	25W
Power supply	220V, 50Hz
Dimension	260×410×280mm
Weight	14kg

OPTIONAL ACCESSORY

TABER CS17 grinding wheel (1 pair)	QMY-AP32-CS17
Glass plate (Ø100mm with a 9mm center hole, 100 pcs/box)	QMY-AP32-GP
Aluminum plate (Ø100mm with a 9mm center hole, 100 pcs/box)	QMY-AP32-AP
180# emery cloth strip (100 pcs/box)	QMY-AP32-EC

PAINT FILM FLEXIBILITY TESTER CODE PPF-BF62

- To test the flexibility of paint and varnish
- Bend the coated test plates on the shaft rods with different diameter, the minimum shaft rod diameter that does not cause damage to the film is the film flexibility



SPECIFICATION

Shaft rod length	35mm
Shaft rod 1	Ø15mm
Shaft rod 2	Ø10mm
Shaft rod 3	Ø5mm
Shaft rod 4	Ø4mm
Shaft rod 5	cross section 3×10mm, radius of curved surface 1.5mm
Shaft rod 6	cross section 2×10mm, radius of curved surface 1.0mm
Shaft rod 7	cross section 1×10mm, radius of curved surface 0.5mm
Dimension	450×75×100mm
Weight	3.1kg

STANDARD DELIVERY

Main unit	1 pc
Test plate	1 box (500 pcs)
4X magnifier	1 pc

OPTIONAL ACCESSORY

Test plate (dimension: 120×25×0.28mm, 500 pcs/box)	PPF-BF62-TP
--	-------------

IMPACT TESTER CODE THD-PF34

- For paint and varnish dry coating. To test the ability to resist cracking or peeling from the substrate when deformation is caused by weights impact under standard conditions
- Indenter, base and weight can be replaced quickly
- Conform to ISO 6272-2:2002, ASTM D 2794



300g main weight (included)



1000g main weight (included)



2lb main weight (included)



2lb additional weight (included)



1000g additional weight (included)

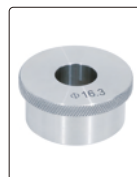

Ø16.3mm die base (included)



Ø12.7mm indenter (included)



Ø15.9mm indenter (included)



SPECIFICATION

Impact height range	0-100cm (0-40inch)
Graduation	1cm
Impact depth	2.5cm
Weight	1000g (2 pcs), 300g (1 pc), 2lb (2 pcs)
Indenter diameter	Ø12.7mm (1/2 inch DIA), Ø15.9mm (5/8 inch DIA)
Die base diameter	Ø16.3mm

OPTIONAL ACCESSORY

Base plate (120×70×0.5mm, 180 pcs/box) *	TD-PF34-T
--	-----------

* Can be customized according to the needs of different thickness, size and processing

STANDARD DELIVERY

Main unit	1 pc
1000g main weight	1 pc
300g main weight	1 pc
2lb main weight	1 pc
1000g additional weight	1 pc
2lb additional weight	1 pc
Ø12.7mm indenter	1 pc
Ø15.9mm indenter	1 pc
Ø16.3mm die base	1 pc



Ultrasonic Thickness Gages
Page 217



Tachometers
Page 218-219



Vibration Pens
Page 219



Laser Distance Meters
Page 220



Portable pH Meters
Page 220-221



Portable Conductivity/TDS Meters
Page 221-222



Refractometers
Page 222-223



Digital Stopwatches
Page 223



Stroke Counters
Page 223



Digital Moisture Meters
Page 223-224



Differential Pressure Manometers
Page 224



Anemometers
Page 225



Bourdon Tube Pressure Gages
Page 226



Digital Sound Level Meters
Page 226



Light Meters
Page 227



Gas Detectors
Page 227-228



Teslameters
Page 228



Laser Belt Tension Meters
Page 229



Digital Glass Thickness Meters
Page 229



Light Transmittance Meters
Page 229

ULTRASONIC THICKNESS GAGE CODE ISU-250C

INSPECTION
CERTIFICATE

DATA
OUTPUT



- Measure the thickness from one side of objects, suitable for pipes, tanks, etc.
- Applicable material: metal, plastic, glass, nylon, resin, ceramic, ice
- Tolerance measurement
- Average calculation of maximum 9 readings
- Data can be input to Excel and Word as keyboard signal



transducer ISU-T12
(optional)



transducer ISU-T06
(optional)



transducer ISU-T04
(optional)



transducer ISU-T13
(optional)

SPECIFICATION (ON STEEL)

Measuring range	refer to specification of transducers
Resolution	0.1/0.01mm
Accuracy	±0.04mm (H<10mm) ±(0.04+H/1000)mm (10≤H<100mm) ±H/333mm (H≥100mm) H is the thickness to be measured in mm
Velocity	1000-9999m/s
Operation temperature of main unit	-20~50°C
Output	USB
Measuring unit	mm/inch
Power supply	2×1.5V AAA batteries
Dimension	64×116×27mm
Weight	220g

STANDARD DELIVERY

Main unit	1 pc
Transducer ISU-T08	1 pc
Battery (AAA)	2 pcs
Couplant (for ISU-T04, ISU-T06, ISU-T08, ISU-T12)	1 bottle
USB cable	1 pc

OPTIONAL ACCESSORY

Transducer	ISU-T04, ISU-T06, ISU-T12, ISU-T13
Couplant (for ISU-T13)	ISU-HT5-COUPPLANT

SPECIFICATION OF TRANSDUCERS (ON STEEL)

Code	Frequency	Diameter (Ød)	Measuring range	Minimum size of pipes for measurement (diameter × wall thickness)	Applicable temperature	Application
ISU-T08 (included)	5.0MHz	11mm	0.8~300mm	Ø25×1.2mm	-20~60°C	general use
ISU-T04 (optional)	10.0MHz	6mm	0.7~20mm	Ø15×1mm	-20~60°C	for small tubes
ISU-T06 (optional)	7.5MHz	9mm	0.7~50mm	Ø15×1.2mm	-20~60°C	for thin workpieces
ISU-T12 (optional)	2.0MHz	17mm	2~400mm	Ø40×3mm	-20~60°C	for casting iron
ISU-T13 (optional)	5.0MHz	15mm	3~100mm	Ø25×2mm	0~350°C	for high temperature

ULTRASONIC THICKNESS GAGE (BASIC TYPE) CODE ISU-100D

ATTENTION: NOT SUITABLE FOR
CASTINGS AND ALUMINUM WORKPIECES

POPULAR
MODEL

INSPECTION
CERTIFICATE



- Measure the thickness from one side of objects, suitable for pipes, tanks, etc.
- Applicable material: steel, stainless steel, glass, copper, brass, polystyrene, titanium, etc.

SPECIFICATION (ON STEEL)

Measuring range	0.8~300mm
Resolution	0.1/0.01mm
Accuracy	±0.05mm (H<10mm) ±(0.05+H/1000)mm (10≤H<100mm) ±H/333mm (H≥100mm) H is the thickness to be measured in mm
Transducer	frequency 5MHz diameter (Ød) 10.8mm
Minimum size of pipes	20×1.2mm (diameter×wall thickness)
Velocity	1000-9999m/s
Operation temperature	main unit: -20~50°C transducer: -20~60°C
Measuring unit	mm/inch
Power supply	2×AAA batteries
Dimension	114×64×28mm
Weight	200g

STANDARD DELIVERY

Main unit	1 pc
Transducer	1 pc
Couplant	1 bottle
Battery (AAA)	2 pcs



CONTACT/NON-CONTACT TACHOMETER CODE 9225-405

- 2 measuring methods, contact and non-contact
- Can measure rotary speed and line speed
- Automatically save the maximum value, minimum value and the last value, 500 data can be stored during continuous measurement
- Automatic power off



cone cavity head (included)



small cone head (included)



wheel with 0.1m perimeter (included)



cone head (included)



clamping sleeve (included)



reflection sticker (included)



SPECIFICATION

Measuring method		non-contact	contact
Measuring range	rotary speed	2.5~99999RPM	0.5~19999RPM
	line speed	—	0.05~500m/min
Resolution	rotary speed	0.1RPM (range 2.5~999.9RPM) 1RPM (range 1000~99999RPM)	0.1RPM (range 0.5~999.9RPM) 1RPM (range 1000~19999RPM)
	line speed	—	0.01m/min (range 0.05~99.99m/min) 0.1m/min (range 100~500m/min)
Accuracy	rotary speed	$\pm(0.05\%n+1d)$ RPM n is rotary speed, d is resolution	$\pm(0.4\%n+1d)$ RPM (n<300RPM) $\pm(0.05\%n+1d)$ RPM (n≥300RPM) n is rotary speed, d is resolution
	line speed	—	$\pm(1\%+1d)$ m/min d is resolution
Laser power		Class 3R, 3mW~4mW	—
Sampling time		0.6s (above 100RPM)	
Measuring distance		50~500mm	—
Operation temperature		0~40°C	
Power supply		3×AA batteries	
Dimension		206×71×36mm	
Weight		170g	

STANDARD DELIVERY

Main unit	1 pc
Reflection sticker	3 pcs
Wheel with 0.1m perimeter	1 pc
Clamping sleeve	1 pc
Cone head	1 pc
Small cone head	1 pc
Cone cavity head	1 pc
Battery (AA)	3 pcs

NON-CONTACT TACHOMETER CODE 9223-120

- Accurately measure the rotary speed without contact
- Automatically save the maximum value, minimum value and the last value, 500 data can be stored during continuous measurement

SPECIFICATION

Measuring range	2.5~99999RPM
Resolution	0.1RPM (range 2.5~999.9RPM) 1RPM (range 1000~99999RPM)
Accuracy	$\pm(0.05\%n+1d)$ RPM n is rotary speed, d is resolution
Laser power	Class 3R, 3mW~4mW
Sampling time	0.6 second (above 100RPM)
Measuring distance	50~500mm
Operation temperature	0~40°C
Power supply	3×AA batteries
Dimension	180×71×29.9mm
Weight	145g



reflection sticker (included)

STANDARD DELIVERY

Main unit	1 pc
Reflection sticker	3 pcs
Battery (AA)	3 pcs

CONTACT TACHOMETER CODE 9224-213



- Can measure rotary speed, line speed and line length
- Automatically save the maximum value, minimum value and the last value, 96 data can be stored during continuous measurement
- With backlight display



wheel with 0.1m perimeter (included)



clamping sleeve (included)



cone cavity head (included)



cone head (included)



small cone head (included)

SPECIFICATION

Measuring range	rotary speed	0.5~19999RPM
	line speed	0.05~500m/min
	line length	0.05~99999m
Resolution	rotary speed	0.1RPM (range 0.5~999.9RPM) 1RPM (range 1000~19999RPM)
	line speed	0.01m/min (range 0.05~99.99m/min) 0.1m/min (range 100~500m/min)
	line length	0.02m
Accuracy	rotary speed	$\pm(0.4\%n+1d)$ RPM ($n<300$ RPM) $\pm(0.05\%n+1d)$ RPM ($n\geq 300$ RPM) n is rotary speed, d is resolution
	line speed	$\pm(1\%+1d)$ m/min d is resolution
	line length	$\pm(1\%+1d)$ m d is resolution
Sampling time		0.8s (above 60RPM)
Operation temperature		0~40°C
Power supply		3×AA batteries
Dimension		171×71×35mm
Weight		162g

STANDARD DELIVERY

Main unit	1 pc
Wheel with 0.1m perimeter	1 pc
Clamping sleeve	1 pc
Cone head	1 pc
Small cone head	1 pc
Cone cavity head	1 pc
Battery (AA)	3 pcs

VIBRATION PEN (THREE PARAMETERS) CODE 0020-A199



- Acceleration, velocity and displacement can be tested
- Automatic power off

STANDARD DELIVERY

Main unit	1 pc
LR44 battery	2 pcs

SPECIFICATION

Parameter	acceleration	velocity	displacement
Measuring range	0.01~199.9m/s ² (peak value)	0.01~199.9mm/s (virtual value)	0.001~1.999mm (peak-peak value)
Frequency	10Hz~1kHz	10Hz~1kHz	10Hz~500Hz
Frequency response	$\pm 5\%$ (≥ 20 Hz) $-20\% \sim +10\%$ (< 20 Hz)		
Linearity	$\pm(5\%+2\text{unit})$		
Indeterminacy of sensitivity	$\leq 3\%$		
Operation temperature	0°C~40°C/32°F~104°F		
Operation humidity	<85%		
Power supply	2×LR44 battery (for 10 hours working)		
Dimension	150×22×18mm		
Weight	55g		

VIBRATION PEN CODE 9720-199



- Measure vibration of motors, fans, pumps, compressors and machine tools to prevent mechanical failure
- Small size, light weight, low energy consumption, easy operation, easy to carry
- One key control
- Automatic power off



VIDEO

STANDARD DELIVERY

Main unit	1 pc
LR44 battery	2 pcs

SPECIFICATION

Measured parameter	speed
Measuring range	0.1~199.9mm/s
Frequency	10Hz~1KHz
Accuracy	$\pm(5\% \pm 2)$ mm/s
Operation temperature	0°C~40°C
Operation humidity	<85%
Power supply	2×LR44 batteries (for 10 hours working)
Dimension	150×22×18mm
Weight	55g

LASER DISTANCE METERS

- Low accuracy models
- Large display with backlight
- Unit: m, ft, in, ft+in
- Distance, area, volume and height measurement
- Continuous measuring mode to track maximum and minimum value
- Memory of 30 measurement values
- Automatic power off: laser 30s, main unit 180s



9561-50B-F

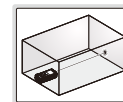

distance measurement

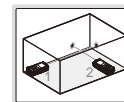

area measurement

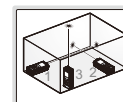

volume measurement

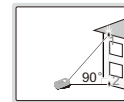

height measurement

SPECIFICATION

Code	9561-50B-F	9561-70B-F
Measuring range	0.2~50m	0.2~70m
Resolution	0.001m, 0.001ft, 1/16"	
Accuracy	$\pm(5+D/20)$ mm D: measured distance, unit: m	
Laser type	red laser, 630~670nm, class II, <1mW	
Power supply	2×AAA batteries	
Dimension (L×W×H)	115×50×28mm	
Weight	95g	

STANDARD DELIVERY

Main unit	1 pc
Battery (AAA)	2 pcs

PEN-TYPE CONDUCTIVITY/TDS/SALINITY TESTER CODE 0412-EB32

IP67
WATERPROOF



- Can measure the conductivity, TDS and salinity
- Suitable for water quality testing, aquaculture, food processing, scientific research, etc.
- The same series of electrodes can be replaced with each other
- Automatic temperature compensation
- With the stabilizing and locking functions of the reading
- Can be used normally in any environment with the background light
- Auto power off
- Protection level: IP67
- Lightweight, easy to carry and operate



"platinum black needle" electrode (included)

SPECIFICATION

Measuring range	conductivity 0~200.0μS/cm, 0~2000μS/cm, 0~20.00mS/cm
	TDS 0~100.0ppm, 0~1000ppm, 0~10.00ppt
	salinity 0~10.00ppt
	temperature 0~50°C
Resolution	conductivity 0.1μS/cm, 1μS/cm, 0.01mS/cm
	TDS 0.1ppm, 1ppm, 0.01ppt
	salinity 0.01ppt
	temperature 0.1°C
Accuracy	conductivity $\pm 1\%$ FS
	temperature $\pm 0.5^\circ\text{C}$
Calibration mode	1~3 points
Power supply	4×1.5V AAA batteries
Dimension	178×40×40mm
Weight	133g



IP67 waterproof



electrodes can be replaced

STANDARD DELIVERY

Main unit	1 pc
Standard solution	2 bottles
Test cup	2 pcs
1.5V AAA battery	4 pcs

PORTABLE CONDUCTIVITY/TDS METER CODE 0411-0200

IP65
WATERPROOF

- Reading mode: auto-read and continuous-read
- Automatic/manual temperature compensation
- Auto-hold feature senses and locks the measurement endpoint
- Cell constant is settable
- 1 point calibration with standard recognition
- Data capacity up to 200 sets for each parameter
- IP65 dust/waterproof
- Auto power off



VIDEO



wristband (included)



standard solution (included)

SPECIFICATION

Conductivity	range	0.00 μ S/cm~200mS/cm
	resolution	0.01 μ S/cm minimum
	electronic unit accuracy	\pm 1.0%FS
	measurement accuracy	\pm 1.5%FS
	reference temperature	25°C/77°F
	calibration point	1
TDS	range	0.00mg/L~300g/L
	resolution	0.01mg/L minimum
	accuracy	\pm 1.0%FS
Temperature	range	-5~110°C/23~230°F
	resolution	0.1°C/0.2°F
	accuracy	\pm 0.4°C/ \pm 0.7°F
Input	electrode with 5-pin aviation connector	
Power supply	rechargeable battery	
Dimension	80×225×35mm	
Weight	400g	

STANDARD DELIVERY

Main unit	1 pc
Electrode	1 pc
Electrode holder	2 pcs
Wristband	1 pc
Silicone rubber case	1 pc
AC/DC adapter and charging cable	1 pc
Standard solution	1 bottle

PEN-TYPE pH TESTER CODE 0432-HB22



IP67
WATERPROOF

- 3 types of pH electrodes: bulb type, plane type and puncture type
- Suitable for water quality testing, sewage treatment, food and cosmetics testing, agriculture and scientific research, etc.
- Can measure the ORP, the same series of electrodes can be replaced with each other
- Automatic temperature compensation
- Alarm function: the red backlight displays alarm mode
- With the stabilizing and locking functions of the reading
- Protection level: IP67
- Can be used normally in any environment with three colors of backlight
- Auto power off
- Lightweight, easy to carry and operate

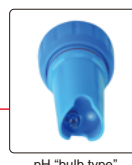

pH "bulb type" electrode (included)



ORP "platinum needles" electrode (optional)

SPECIFICATION

Measuring range	-2.00~16.00pH
	temperature 0~50°C
	ORP -1000mV~+1000mV
Resolution	0.01pH
	temperature 0.1°C
	ORP 1mV
Accuracy	\pm 0.02pH
	temperature \pm 0.5°C
	ORP \pm 0.2%FS
Calibration mode	1~3 points
Standard solution	USA (pH buffers: 4.00, 7.00, 10.01) NIST (pH buffers: 4.01, 6.86, 9.18)
Power supply	4×1.5V AAA batteries
Dimension	178×40×40mm
Weight	133g

STANDARD DELIVERY

Main unit	1 pc
Standard solution	3 bottles (USA)
Test cup	3 pcs
KCl powder	1 bottle
1.5V AAA battery	4 pcs

OPTIONAL ACCESSORY

pH plane type electrode	0432-HB-F
pH puncture type electrode	0432-HB-P
ORP electrode	0432-HB-O



pH "puncture type" electrode (optional)



pH "plane type" electrode (optional)



**PORTABLE pH METER
CODE 0431-0018**

**IP65
WATERPROOF**



- Reading mode: auto-read and continuous-read
- Automatic/manual temperature compensation
- Auto-hold feature senses and locks the measurement endpoint
- 1 or 2 points calibration with standard recognition
- Data capacity up to 200 sets for each parameter
- IP65 dust/waterproof
- Auto power off

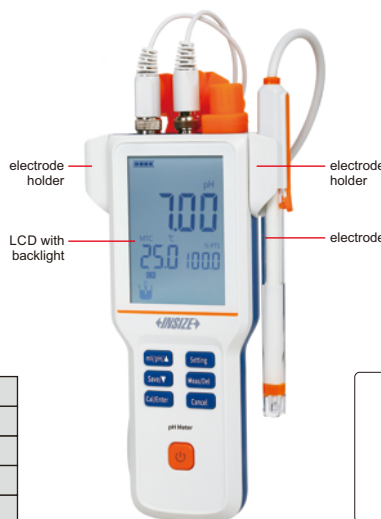

KCl powder (included)



wristband (included)



standard solution (included)

SPECIFICATION

pH	range	-2.00~18.00pH
	resolution	0.01pH
	electronic unit accuracy	±0.01pH
	measurement accuracy	±0.02pH
	calibration point	1 or 2
Voltage	range	-1999~1999mV
	resolution	1mV
	accuracy	±0.1%FS
	standard recognition	NIST pH buffers: 4.01, 7.00, 10.01
Temperature	range	-5~110°C/23~230°F
	resolution	0.1°C/0.2°F
	accuracy	±0.4°C/±0.7°F
Inputs	pH electrode: BNC (Q9) temp. probe: 4-pin aviation connector	
Power supply	rechargeable battery	
Dimension	80×225×35mm	
Weight	400g	

STANDARD DELIVERY

Main unit	1 pc
Electrode	1 pc
Electrode holder	2 pcs
Wristband	1 pc
Silicone rubber case	1 pc
AC/DC adapter and charging cable	1 pc
Standard solution	3 bottles
KCl powder	1 bottle

**DIGITAL REFRACTOMETER
CODE ISQ-DRM31**

**SUITABLE FOR WATER
BASED COOLANT**



- Quickly measure the concentration of coolant, sugar solution, juice and drinks
- Two measurement modes: single measurement and automatic average multiple measurement
- Two units: brix and refractive index
- Refer to the refraction factor of coolant, for example: the refraction factor of grinding emulsion is 2.1, the reading value is 6%, so the actual concentration is (2.1×6%)=12.6%
- Automatic power off

STANDARD DELIVERY

Main unit	1 pc
Dropper	1 pc
Battery (AAA)	1 pc

SPECIFICATION

Measuring range	0~50% (1.3330~1.4200RI)
Accuracy	±0.2% (±0.0003RI)
Resolution	0.1% (0.0001RI)
Power supply	1×AAA battery
Dimension	121×58×25mm
Weight	90g

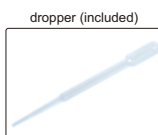

**MINI DIGITAL REFRACTOMETER
CODE 5801-A55**

**SUITABLE FOR WATER
BASED COOLANT**



- Quickly measure the concentration of coolant
- Automatic temperature compensation
- Brix and refractive index can be displayed
- Refer to the refraction coefficient of coolant, for example: the refraction coefficient of grinding emulsion is 2.1, the reading value is 6%, so the actual concentration is (2.1×6%)=12.6%
- Automatic power off

STANDARD DELIVERY

Main unit	1 pc
Dropper	1 pc

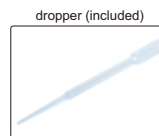

SPECIFICATION

Measuring range	0~50% (1.3330~1.4200RI)
Accuracy	±0.2% (±0.0003RI)
Resolution	0.1% (0.0001RI)
Power supply	built-in 3.7V rechargeable lithium battery
Dimension	147×46×27mm
Weight	115g (including battery)

PORTABLE REFRACTOMETER CODE ISQ-RM30

SUITABLE FOR WATER
BASED COOLANT

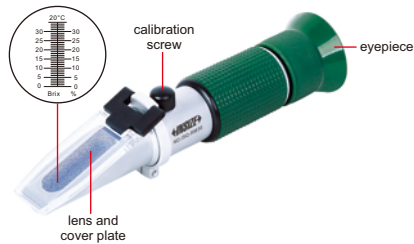

- Quickly measure the concentration of coolant
- Refer to the refraction factor of coolant, for example: the refraction factor of grinding emulsion is 2.1, the reading value is 6%, so the actual concentration is $(2.1 \times 6\%) = 12.6\%$



SPECIFICATION

Measuring range	0~32%
Graduation	0.2%
Dimension	27×40×160mm
Weight	175g

DIGITAL STOPWATCH CODE DSW-A010



- Split time, total time and continuous time can be displayed
- 10 groups of results can be read out from memory after resetting
- Scroll back and forth to read out the memory digits
- The fastest, slowest and average time can be displayed
- Able to record the split times (00-199)

SPECIFICATION

Measuring range	0~9 hours, 59 minutes, 59.99 seconds	
Resolution	0.01s	
Accuracy	±0.5s	
Function	memory	10 groups
	timer	up to 10 hours
	time	12-hour or 24-hour time display, alarm can be set
Power supply	LR44 battery	
Screen dimension	33.6×13.6mm	
Dimension	76×63×16mm (metal case)	

STANDARD DELIVERY

Main unit	1 pc
String	1 pc

STROKE COUNTER CODE 7600-6

- Accumulate and record the number of mechanical movements
- Rotate back to zero

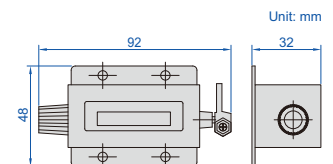

SPECIFICATION

Code	Number of digits	Range
7600-6	6	0-999999

DIGITAL MOISTURE METER CODE 9341-50



- Suitable for wood, smooth cement, hard gypsum, mixed mortar, brick, etc.
- Measure moisture, temperature and relative humidity
- Temperature type: ambient, dew point, wet bulb
- Maximum and minimum modes
- Automatic power off

SPECIFICATION

Measuring depth	0~50mm	
Measuring range	moisture	0~60%
	temperature	-10~50°C/14~122°F
	relative humidity	0~100%RH
Accuracy	moisture	±2%
	temperature	±2%
	relative humidity	±5%RH
Resolution	moisture	0.1%
	temperature	0.1°C/0.1°F
	relative humidity	0.1%RH
Sampling time	0.5s for moisture 1s for temperature and relative humidity	
Power supply	2×AAA batteries	
Dimension	130×56×29mm	
Weight	206g	

STANDARD DELIVERY

Main unit	1 pc
Battery (AAA)	2 pcs

INDUCTIVE MOISTURE METER CODE 0120-IM24

- Suitable for wood, gypsum and cement
- MAX/MIN/HOLD mode
- Alarm function
- Low battery indication
- Auto power off



SPECIFICATION

Measuring range	0~100%
Resolution	1%
Accuracy	±4%
Detection depth	20~40mm
Sampling time	0.5s
Battery	9V
Dimension	185×55×38mm
Weight	193g

STANDARD DELIVERY

Main unit	1 pc
Battery	1 pc

DIFFERENTIAL PRESSURE MANOMETER CODE 0140-DP05

- Offset and differential measurement
- Record maximum/minimum/average value with relative timestamp
- Built-in USB interface for data transmission
- Unit: psi, inH₂O, bar, mbar, kPa, inHg, mmHg, oz/in², ftH₂O, cmH₂O, kg/cm²
- Zero adjust
- Data hold
- Display with backlight
- Low battery indication
- Automatic power off
- Safety rating: CAT III 600V



soft tubes (included)

SPECIFICATION

Pressure range	-5~5psi											
Maximum pressure	20psi											
Unit	psi	inH ₂ O	bar	mbar	kPa	inHg	mmHg	oz/in ²	ftH ₂ O	cmH ₂ O	kg/cm ²	
Range	5	138.3	0.344	344.7	34.47	10.18	258.5	80	11.53	351.5	0.351	
Resolution	0.001	0.1	0.001	0.1	0.01	0.01	0.1	0.01	0.01	0.1	0.001	
Accuracy	±0.3%FSO (25°C)											
Repeatability	±0.2% (Max. ±0.5%FSO)											
Linearity/hysteresis	±0.29%FSO											
Response time	0.5s typical											
Operation temperature	0°C~50°C											
Power supply	1×9V 6F22 battery or AC/DC adapter											
Dimension (LxWxH)	165×90×40mm											
Weight	350g											

STANDARD DELIVERY

Main unit	1 pc
AC/DC adapter	1 pc
9V battery	1 pc
Software flash disk	1 pc
USB cable	1 pc
Soft tubes	4 pcs

software (included), connect to PC via USB cable

display realtime value and curve

export data to Excel

ANEMOMETER CODE 0110-1125

- Measure air velocity and temperature
- Min/Max, data hold function
- Bluetooth 4.0
- Auto power off
- Supplied with APP for Apple and Android

SPECIFICATION

	Unit	Measuring range	Resolution	Accuracy
Air velocity	m/s	1.1~25.0	0.01	±(3%+0.3)
	km/h	4~90	0.1	±(3%+1)
	ft/min	220~4920	1	±(3%+40)
	MPH	2.5~56.0	0.1	±(3%+0.4)
	knots	2.2~48.0	0.1	
Air temperature	°C	0~50	0.1	±2
	°F	32~122	0.1	±4
Sensors	air velocity sensor, NTC-type precision thermistor			
Sampling time	0.5s			
Operation altitude	max 2000m			
Operation environment	0~50°C, 0~80%RH			
Storage environment	-10~60°C, 0~80%RH			
Auto power off	10 minutes			
Data port	Bluetooth 4.0			
Power supply	9V			
Dimension	213×54×36mm			
Weight	172g			



App measurement



App record

No.	Data value	Data value
	°C	°RH
1	23.10	0.22
2	23.10	0.00
3	23.00	0.00
4	23.10	4.59
5	23.10	1.85
6	23.00	1.06
7	23.00	0.72
8	23.00	0.44
...

STANDARD DELIVERY

Main unit	1 pc
Battery	1 pc

DIGITAL ANEMOMETER CODE 9331-40

- Measure velocity, flow, temperature and relative humidity
- Velocity unit: m/s, km/h, mil/h, ft/m, ft/s, knots
- Flow unit: CMS (cubic meter per second), CMM (cubic meter per minute), CFM (cubic feet per minute)
- Temperature type: ambient, dew point, wet bulb
- Maximum and minimum modes
- Automatic power off

SPECIFICATION

Measuring range	velocity	0.8~30m/s, 2.88~108km/h, 1.8~67.2mil/h, 2.62~98.5ft/s, 157.5~5900ft/m, 1.6~58.3knots
	flow	0~99.99CMS, 0~999.9CMM, 0~999.9CFM
	temperature	-10~60°C/14~140°F
	relative humidity	0~100%RH
Accuracy	velocity	±(2%+0.5) for m/s, km/h, mil/h, ft/s, knots ±(2%+50) for ft/m
	temperature	±1.5°C/±2.7°F
	relative humidity	±3% (20~80%RH), ±5% (<20%RH or >80%RH)
Resolution	velocity	0.01m/s, 0.01km/h, 0.01mil/h, 0.01ft/s, 1ft/m, 0.01knots
	flow	0.01CMS, 0.1CMM, 0.1CFM
	temperature	0.1°C/0.1°F
	relative humidity	0.1%RH
Flowing area range	0~9.999m²/0~9.999ft²	
Sampling time	0.4s	
Maximum working height	2000m	
Output	USB	
Power supply	9V battery	
Dimension	165×85×38mm	
Weight	200g	



DATA
OUTPUT

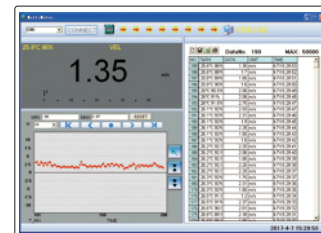

software (included), display measurement values and graph, save and output data

STANDARD DELIVERY

Main unit	1 pc
Software and USB cable	1 pc
9V battery	1 pc



software flash disk (included)

BOURDON TUBE PRESSURE GAGES (LIQUID FILLED)

CAN BE
CUSTOMIZED

- Stainless steel case and bezel, copper alloy internals
- Shock-proof and pulse-proof
- Suitable for pneumatic system, hydraulic system and compressed air system



5201-63B2Y10

SPECIFICATION

Accuracy class	1.6
Ambient temperature	-20~60°C
Medium temperature	≤60°C

Dial size	Ø63mm		
Process connection	1/4BSP	1/4ZG	1/4NPT
Connector location	bottom	bottom	bottom
Range (0~10bar/0~150psi)	5201-63B2Y10	5201-63Z2Y10	5201-63N2Y10

DIGITAL SOUND LEVEL METER CODE 9351-130

DATA
OUTPUT

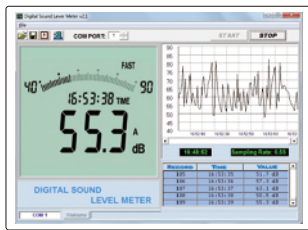

VIDEO



software (included), display measurement values and graph, save and output data

- Automatically select best range: 30~80dB, 40~90dB, 50~100dB, 60~110dB, 70~120dB, 80~130dB
- Over range indicator
- Real time, average, maximum modes
- Memory 16000 measurement values
- AC signal output: 0.707 Vrms at FS, impedance approx. 600Ω
- DC signal output: 10mV/dB, impedance approx. 100Ω
- Automatic power off

SPECIFICATION

Measuring range	30~130dB
Accuracy	±2dB
Resolution	0.1dB
Sampling time	0.5s for digital, 0.05s for analogue
Response time	fast: 125ms, slow: 1s
Frequency	30Hz~8KHz
Frequency weighting	A/C
Microphone	electret condenser type
Output	RS232, AC/DC
Power supply	6×AAA batteries
Dimension	265×80×69mm
Weight	317g

STANDARD DELIVERY

Main unit	1 pc
Software and RS232 cable	1 pc
Output connector	1 pc
Battery (AAA)	6 pcs



software flash disk (included)

DIGITAL SOUND LEVEL METER (ADVANCED TYPE) CODE 9353-413

- Automatic range conversion
- Over range indicator
- Maximum mode
- Data hold
- AC signal output: 0.707Vrms, impedance approx. 100Ω
- DC signal output: 20mV/dB, impedance approx. 1kΩ



STANDARD DELIVERY

Main unit	1 pc
Battery (AAA)	4 pcs
Screwdriver	1 pc

SPECIFICATION

Measuring range	40dB~130dB (ref.20μPa)
Frequency	20Hz~12.5kHz
Resolution	0.1dB
Accuracy	IEC 61672-1:2013 Class 2
Frequency weighting	A weighting
Response time	fast (125ms), slow (1s)
Microphone	pre polarization condenser microphone
Reference direction	axial direction of condenser microphone
Power supply	4×1.5V AAA batteries
Dimension	210×68×27mm
Weight	240g

SOUND LEVEL METER (BASIC TYPE) CODE 0010-A35

App measurement

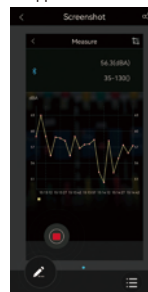

App record

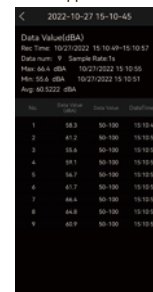

- Auto range selection
- Over range indication
- Display backlight
- Min/Max, data hold function
- Bluetooth 4.0
- Auto power off
- Supplied with APP for Apple and Android

STANDARD DELIVERY

Main unit	1 pc
Battery	1 pc
Windscreen	1 pc

SPECIFICATION

Frequency	31.5Hz~8KHz
Measuring range	35dB~130dB
Accuracy	±3.0dB (ref 94dB@1kHz)
Resolution	0.1dB
Frequency weighting	A and C
Display update	2 times/sec
Microphone	1/2 inch electret condenser microphone
Power supply	9V battery
Operation temperature and humidity	0°C~40°C/32°F~104°F, 10%RH~90%RH
Dimensions	185×54×36mm
Weight	184g

LIGHT METER CODE 0131-A120



- Photosensor can rotate 90° clockwise and rotate 180° counterclockwise
- Build-in calibration filters ensure the accuracy when working in different colors
- Data hold function
- Lux/FC unit switch
- Low battery warning

SPECIFICATION

Measuring range	0.1~199.9Lux	1~1999Lux	10~19990Lux	100~199900Lux
Resolution	0.1Lux	1Lux	10Lux	100Lux
Measuring range	0.01~19.99FC	0.1~199.9FC	1~1999FC	10~19990FC
Resolution	0.01FC	0.1FC	1FC	10FC
Accuracy	±(4%+10d), range<20000Lux/2000FC ±(5%+10d), range≥20000Lux/2000FC (d is resolution, calibrated with standard incandescent lamp at color temperature 2856K)			
Repeatability	±2%			
Sampling time	0.5s			
Operation environment	0~40°C, 0~70%RH			
Storage environment	-10~50°C, 0~80%RH			
Battery	9V			
Dimension	185×68×38mm			
Weight	130g			

STANDARD DELIVERY

Main unit	1 pc
Battery	1 pc

LIGHT METER (BASIC TYPE) CODE 0130-L110



- Suitable for measuring illuminance in various occasions
- Data hold function
- Fast switching of measuring range, easy to operate

STANDARD DELIVERY

Main unit	1 pc
Battery	1 pc

SPECIFICATION

Measuring range	1~1999Lux	10~19990Lux	100~100000Lux
Resolution	1Lux	10Lux	100Lux
Accuracy	±(4%+10d), range<10000Lux ±(5%+10d), range≥10000Lux (d is resolution, calibrated with standard incandescent lamp at color temperature 2856K)		
Repeatability	±2%		
Sampling time	0.5s		
Operation environment	0~40°C, 0~70%RH		
Storage environment	-10~50°C, 0~80%RH		
Battery	9V		
Photodetector dimension	105×58×28mm		
Main unit dimension	130×72×30mm		
Weight	170g		

SINGLE GAS DETECTORS

IP65
WATERPROOF



0611-SG01



calibration cap (included)

- Detect combustible gas (EX, including CH₄, C₃H₈, H₂, etc), O₂, CO or H₂S, support more than 30 types of gas sensors, customization for detecting toxic gases (such as NO, NH₃, PH₃, etc) available
- Adjustable alarm level, alarm mode: sound, light, vibration
- Adjustable calibration level
- Sampling method: natural diffusion
- High concentration protection for sensor
- Up to 500 alarm records storage capacity
- Self-test on startup
- Display with backlight
- Language: English, Chinese
- Low battery indication
- Explosion proof level: Ex ib IIB T3 Gb

SPECIFICATION

Code	0611-SG01	0611-SG02	0611-SG03	0611-SG04
Gas	combustible gas/EX	O ₂	CO	H ₂ S
Range	0-100%LEL	0-30%vol	0-1000ppm	0-100ppm
Resolution	1%LEL	0.1%vol	1ppm	1ppm
Accuracy	±5%FS			
Response time	T ₉₀ <60s			
Operation environment	temperature: -10°C~55°C; humidity: <95%RH, no condensation			
Sensor lifetime	2 years (depending on working environment)			
Power supply	3.7V rechargeable Li-ion battery, working time>8h			
Dimension (LxWxH)	124×60×46mm			
Weight	205g			

STANDARD DELIVERY

Main unit	1 pc
Calibration cap	1 pc
AC/DC adapter and charging cable	1 pc

MULTI GAS DETECTOR CODE 0612-MG04

DATA
OUTPUT

IP66
WATERPROOF



software flash disk
(included)



charging cable (included)



calibration cap (included)



charging and data transmission
interface on the back

STANDARD DELIVERY

Main unit	1 pc
Calibration cap	1 pc
Software and USB cable	1 pc
AC/DC adapter	1 pc

- Detect combustible gas (EX, including CH₄, C₂H₆, H₂, etc), oxygen (O₂), carbon monoxide (CO) and hydrogen sulfide (H₂S), optional configuration includes other toxic gases such as NO, NH₃, PH₃, etc; support more than 30 types of gas sensors, flexible sensor combination and customization available
- Adjustable alarm level, alarm mode: sound, light, vibration and screen display
- Adjustable calibration level
- Sampling method: natural diffusion
- High concentration protection for sensor
- Data transmission via charging interface
- Up to 1000 alarm records storage capacity
- Self-test on startup
- Display with backlight
- Language: English, Chinese and Spanish (Portuguese and Russian customizable)
- Low battery indication
- Explosion proof level: Ex ib IIC T4 Gb

software (included), connect to PC via USB cable, display test data and export record

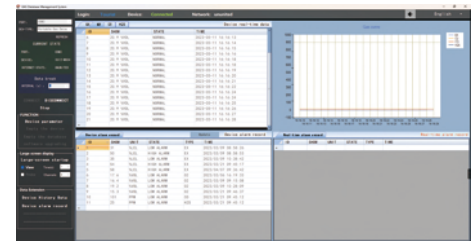

display real-time data and alarm record

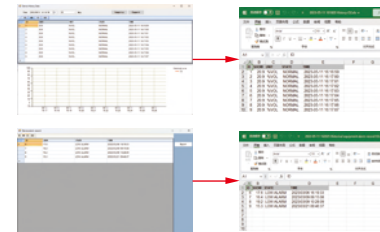

export history data and alarm record

SPECIFICATION

Gas	combustible gas (EX)	O ₂	CO	H ₂ S
Range	0-100%LEL	0-30%vol	0-1000ppm	0-100ppm
Resolution	1%LEL	0.1%vol	1ppm	1ppm
Accuracy	±5%FS			
Response time	T ₉₀ <60s			
Operation environment	temperature: -10°C~50°C; humidity: <95%RH, no condensation			
Sensor lifetime	2 years (depending on working environment)			
Power supply	3.7V rechargeable Li-ion battery, working time>8h			
Dimension (LxWxH)	150×72×48mm			
Weight	310g			

TESLAMETERS (GAUSSMETERS)

DATA
OUTPUT

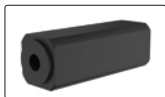

magnetic shielding cavity
(optional)



axial probe (optional)



0501-MA01

radial probe
(included)

- Measure magnetic induction of DC magnetic field
- Directly display the N/S polarity of the measured magnetic field
- One-key zero function: eliminate the influence of zero drift before measurement
- Maximum value hold: record the maximum value of the changing magnetic field
- Unit switch between mT or G (1mT=10G)
- Auto ranging
- Built-in USB interface for data transmission
- Display with backlight
- Auto power off

STANDARD DELIVERY

Main unit	1 pc
Radial probe	1 pc
Battery (AA)	3 pcs

OPTIONAL ACCESSORY

Axial probe	0501-PA
Magnetic shielding cavity	0501-SHIELD

SPECIFICATION

Code	0501-MA01	0501-MA05
Range	2000mT	
Resolution	0.01mT (0~200mT) 0.1mT (200~2000mT)	
Accuracy	±1.0%	±2.0% (≤1000mT) ±5.0% (1000mT~2000mT)
Temperature coefficient	±0.1%/K	
Zero drift	±0.5mT/h	
Interface	USB	
Power supply	3×1.5V AA batteries or USB	
Dimension (L×W×H)	165×90×40mm	
Weight	350g	

LASER BELT TENSION METER CODE 5900-HZ18



- Laser sensor, direct measurement, easy to use
- Two sensors: internal and external, external sensor is suitable for measurement in narrow spaces
- Automatic power off



SPECIFICATION

Measuring range	10~800Hz	
Input parameter range	maximum free belt length: 99.99m maximum belt weight: 9.999kg/m	
Accuracy	±5%	
Unit	N, lbf	
Measuring distance	3~20mm	
Operation temperature	10~50°C	
Power supply	4×1.5V AAA batteries	
Dimension	main unit	178×72×34mm
	external sensor	124×21×12mm
Weight	180g	

STANDARD DELIVERY

Main unit	1 pc
External sensor	1 pc

DIGITAL GLASS THICKNESS METER CODE 5805-GT22



- Laser reflection principle to measure the thickness of glass and internal air layer. Especially suitable for building laminated glasses, hollow glass windows, etc.
- To test the thickness of single layer glasses, multi-layer glasses, two glasses with one cavity, three glasses with two cavities, laminated glasses, laminated insulating glasses, etc.

SPECIFICATION

Measuring range	glass thickness (0~70mm), air layer (0~45mm)
Accuracy	±0.1mm (measuring range≤63mm), ±0.2mm (measuring range>63mm)
Resolution	0.01mm
Display	LCD
Power supply	4×1.5V AAA batteries
Dimension	130×72×33mm
Weight	330g

STANDARD DELIVERY

Main unit	1 pc
Cross screwdriver	1 pc
1.5V AAA battery	4 pcs



LIGHT TRANSMITTANCE METER CODE 5804-LT21



- Suitable for light transmittance testing of various "regular transmission materials", such as building glasses, auto glasses, transparent films, plastic products, etc.
- With the design of parallel optical path of the light source and condensed light of the receiver, it can measure up to 100mm thickness
- Can measure the high transparent materials such as K9 glasses
- Two measuring modes, fixed base and handheld
- Conforming to CIE photopic luminosity function

SPECIFICATION

Optical source	380nm~760nm, conforming to CIE photopic luminosity function
Measuring range	0.001%~99.8%
Accuracy	±1%
Resolution	0.001% (0%~10%), 0.01% (10%~100%)
Thickness to be measured	<100mm
Diameter to be measured	>10mm
Power supply	4×1.5V AAA batteries
Dimension	75×140×25mm
Weight	634g

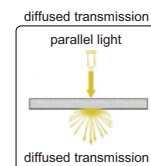
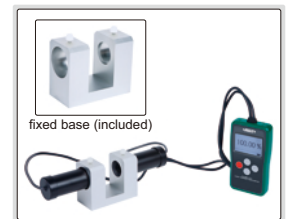

when the light penetrates a material with a rough surface or uneven texture, the light spreads out

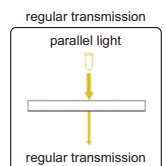

when the light penetrates a flat and evenly textured transparent material, the light does not change its direction

STANDARD DELIVERY

Main unit	1 pc
Transmitter	1 pcs (connect to main unit)
Receiver	1 pcs (connect to main unit)
Fixed base	1 pc
1.5V AAA battery	4 pcs



DC Resistance Testers
Page 231



DC Power Supplies
Page 231



Digital Multimeters
Page 232-234



Digital AC/DC Clamp Meters
Page 235



Voltage Testers
Page 235

DC RESISTANCE TESTER CODE 9651-RM20



temperature probe (included)



test clip (included)



RS232 communication cable (included)



VIDEO

SPECIFICATION

Function	Range	Resolution	Accuracy ("d" is the least reading)
Slow test	20mΩ	0.001mΩ	±(0.1%+3d)
	200mΩ/2Ω/20Ω/200Ω/ 2kΩ/20kΩ/200kΩ	0.001mΩ/0.00001Ω/0.0001Ω/0.001Ω/ 0.00001kΩ/0.0001kΩ/0.001kΩ	±(0.05%+2d)
	2MΩ	0.0001MΩ	±(0.1%+5d)
Medium test	20mΩ	0.001mΩ	±(0.2%+5d)
	200mΩ/2Ω/20Ω/200Ω/ 2kΩ/20kΩ/200kΩ	0.001mΩ/0.00001Ω/0.0001Ω/0.001Ω/ 0.00001kΩ/0.0001kΩ/0.001kΩ	±(0.1%+3d)
	2MΩ	0.0001MΩ	±(0.2%+5d)
Fast test	20mΩ	0.01mΩ	±(0.8%+5d)
	200mΩ/2Ω/20Ω/200Ω/ 2kΩ/20kΩ/200kΩ	0.01mΩ/0.0001Ω/0.001Ω/0.01Ω/ 0.0001kΩ/0.001kΩ/0.01kΩ	±(0.5%+5d)
	2MΩ	0.001MΩ	±(0.8%+5d)
Range mode	auto range, manual range and nominal range		
Test speed	slow: 3t/s, medium: 18t/s, fast: 60t/s		
Trigger	internal trigger, manual trigger, external trigger		
Interface	handler interface, RS232 interface, RS485 interface, USB interface and temperature compensation interface		
Power supply	AC: 100V~240V, 50Hz/60Hz		
Dimension (L×W×H)	307×264×107mm		
Weight	2.5kg		

- Maximum reading: 220000
- Basic accuracy: 0.05%
- 3.5 inch LCD screen
- Temperature compensation function
- Short-circuit zeroing calibration
- Bad contact detection
- Comparator: pass or fail judge
- Keyboard lock function

STANDARD DELIVERY

Main unit	1 pc
RS232 communication cable	1 pc
Temperature probe	1 pc
Test clip	1 pc

DC POWER SUPPLY CODE 9911-PS305



VIDEO



- Four-digit LED display
- Output power display
- Output switch control
- 10mV/1mA high accuracy and resolution
- Panel locking function to prevent misoperation
- USB interface for power supply
- OVP/OCP protection
- 3 shortcut keys for presetting

STANDARD DELIVERY

Main unit	1 pc
Test lead	2 pcs



test leads (included)

SPECIFICATION

Voltage	range	30V
	setting resolution	10mV
	setting accuracy	≤0.1%+10mV
	readback resolution	10mV
	readback accuracy	≤0.1%+10mV
	load regulation	≤0.1%+5mV
	line regulation	≤0.01%+5mV
Current	ripple	10mVrms
	range	5A
	setting resolution	1mA
	setting accuracy	≤0.2%+10mA
	readback resolution	1mA
	readback accuracy	≤0.2%+10mA
	load regulation	≤0.2%+3mA
OVP	line regulation	≤0.2%+3mA
	ripple	8mArms
OCP		0~33V
Work condition		0~5.5A
Storage condition		temperature: 0~40°C, humidity: ≤80%RH
Cool system		temperature: -20~60°C, humidity: ≤80%RH
Power supply		fan cool
Dimension (L×W×H)		AC 220V±10%, 50Hz/60Hz
Weight		230×80×150mm
		1.45kg

PEN-TYPE DIGITAL MULTIMETER CODE 9241-ML200

- Auto/manual ranging
- Maximum mode
- Data hold
- NCV detection
- Low battery indication
- Auto power off
- Safety rating: CAT III 600V



test lead (included)



clips (included)

SPECIFICATION

Function	Range	Resolution	Accuracy
DC Voltage	200mV/2V/20V/200V/600V	0.1mV/1mV/10mV/0.1V/1V	$\pm(0.7\%+2)$
	200mV/2V/20V/200V	0.1mV/1mV/10mV/0.1V	$\pm(0.8\%+3)$
AC Voltage	600V	1V	$\pm(1.0\%+3)$
	20mA/200mA	10 μ A/0.1mA	$\pm(1.5\%+3)$
DC Current	20mA/200mA	10 μ A/0.1mA	$\pm(2.0\%+3)$
Resistance	200 Ω	0.1 Ω	$\pm(1.0\%+3)$
	2k Ω /20k Ω /200k Ω /2M Ω	1 Ω /10 Ω /0.1k Ω /1k Ω	$\pm(1.0\%+1)$
	20M Ω	10k Ω	$\pm(1.0\%+5)$
Logic level test	<1.5V (green LED on) 1.5~3.5V (green & red LED off) >3.5V (red LED on)		
Diode	open circuit voltage 1.5V		
Continuity buzzer	<50 Ω		
Power supply	2 \times 1.5V AAA batteries		

STANDARD DELIVERY

Main unit	1 pc
Test lead	1 pc
Clip	2 pcs
Battery (AAA)	2 pcs

DIGITAL MULTIMETER CODE 9216-F520

SPECIFICATION

Function	Range	Resolution	Accuracy ("d" is the least reading)
DC Voltage	200mV	0.1mV	$\pm(0.5\%+2d)$
	2V/20V/200V	0.001V/0.01V/0.1V	$\pm(1.0\%+2d)$
	600V	1V	$\pm(1.2\%+2d)$
AC Voltage (50~60Hz)	200mV	0.1mV	$\pm(1.5\%+30d)$
	2V	0.001V	$\pm(1.2\%+3d)$
	20V/200V	0.01V/0.1V	$\pm(1.5\%+3d)$
	600V	1V	$\pm(2.0\%+4d)$
DC Current	200 μ A	0.1 μ A	$\pm(1.0\%+3d)$
	2000 μ A/20mA/200mA	1 μ A/0.01mA/0.1mA	$\pm(1.5\%+3d)$
	10A	0.01A	$\pm(2.5\%+5d)$
AC Current (50~60Hz)	200 μ A	0.1 μ A	$\pm(1.5\%+5d)$
	2000 μ A/20mA/200mA	1 μ A/0.01mA/0.1mA	$\pm(1.8\%+5d)$
	10A	0.01A	$\pm(3.0\%+7d)$
Resistance	200 Ω	0.1 Ω	$\pm(1.2\%+4d)$
	2k Ω	0.001k Ω	$\pm(1.0\%+2d)$
	20k Ω /200k Ω /2M Ω	0.01k Ω /0.1k Ω /0.001M Ω	$\pm(1.2\%+2d)$
	20M Ω	0.01M Ω	$\pm(2.0\%+3d)$
Temperature (type-K)	-50 $^{\circ}$ C to 1000 $^{\circ}$ C	1 $^{\circ}$ C	$\pm(3.0\%+5^{\circ}$ C)
	-58 $^{\circ}$ F to 1832 $^{\circ}$ F	1 $^{\circ}$ F	$\pm(3.0\%+8^{\circ}$ F)
Diode test	test current: 0.3mA typical	1mV	$\pm(1.0\%+5d)$
Continuity check	less than 100 Ω		
Power supply	9V battery		
Dimension (LxWxH)	150 \times 70 \times 48mm		
Weight	255g		



- 2000 counts digital display
- Auto ranging (except 200mV AC)
- Data hold
- Max hold
- Display with backlight
- Low battery indication
- Auto power off
- Safety rating: CAT III 600V



test leads (included)



temperature probe and adapter (included)

STANDARD DELIVERY

Main unit	1 pc
Thermocouple adapter	1 pc
Temperature probe	1 pc
9V battery	1 pc
Test lead	2 pcs

MINI DIGITAL MULTIMETER (BASIC TYPE) CODE 9242-ML100A

POPULAR
MODEL

- Portable size with protective case
- 1999 counts digital display
- Data hold
- Display with backlight
- Low battery indication
- Auto power off
- Safety rating: CAT II 600V



VIDEO



SPECIFICATION

Function	Range	Resolution	Accuracy ("d" is the least reading)
DC Voltage	200.0mV	0.1mV	$\pm(0.7\%+3d)$
	2000mV	1mV	$\pm(0.5\%+2d)$
	20.00V/200.0V/600V	0.01V/0.1V/1V	$\pm(0.7\%+3d)$
AC Voltage (40~400Hz)	200.0V/600V	0.1V/1V	$\pm(1.2\%+3d)$
DC Current	200.0μA/200.0mA	0.1μA/0.1mA	$\pm(1.0\%+2d)$
	10.00A	0.01A	$\pm(1.2\%+5d)$
Resistance	200.0Ω	0.1Ω	$\pm(1.0\%+2d)$
	2000Ω/20.00kΩ/200.0kΩ	1Ω/0.01kΩ/0.1kΩ	$\pm(0.8\%+2d)$
	20.00MΩ	0.01MΩ	$\pm(1.2\%+3d)$
Battery test	1.5V/9V/12V battery check		
Diode test	open circuit voltage: 2.1V DC		
Continuity check	<50Ω		
Power supply	2×1.5V AAA batteries		
Dimension (LxWxH)	134×77×47mm		
Weight	206g		



test leads (included)

STANDARD DELIVERY

Main unit	1 pc
Battery (AAA)	2 pcs
Test lead	2 pcs

SMART DIGITAL MULTIMETER CODE 9247-190

- Automatically identify test mode for AC voltage/DC voltage/resistance/continuity
- Non-connection AC voltage detection, and judge the strength by light and buzzer
- Self-calibration when power on to ensure accuracy
- LIVE firewire recognition
- Display with backlight
- True RMS measurement
- Data hold
- Low battery indication
- Auto power off
- Safety rating: CAT III 600V



test leads (included)



VIDEO

STANDARD DELIVERY

Main unit	1 pc
Test lead	2 pcs
Battery (CR2032)	2 pcs

SPECIFICATION

Function	Range	Resolution	Accuracy
DC Voltage	60mV/600mV/6V/60V/600V	0.01mV/0.1mV/0.001V/0.01V/0.1V	$\pm(0.5\%+3)$
AC Voltage	60mV/600mV/6V/60V/600V	0.01mV/0.1mV/0.001V/0.01V/0.1V	$\pm(1.0\%+3)$
DC Current	6000μA/60mA/600mA	1μA/0.01mA/0.1mA	$\pm(1.2\%+5)$
AC Current	6000μA/60mA/600mA	1μA/0.01mA/0.1mA	$\pm(1.5\%+5)$
Resistance	600Ω/6kΩ/60kΩ/600kΩ	0.1Ω/0.001kΩ/0.01kΩ/0.1kΩ	$\pm(1.0\%+5)$
	6MΩ/60MΩ	0.001MΩ/0.01MΩ	$\pm(1.5\%+3)$
Capacitance	6nF/60nF/600nF/6μF/60μF/600μF	0.001nF/0.01nF/0.1nF/0.001μF/0.01μF/0.1μF	$\pm(4.0\%+5)$
	6mF/60mF	0.001mF/0.01mF	$\pm(5.0\%+5)$
Frequency	10Hz/100Hz/1000Hz/10kHz/100kHz/1000kHz	0.001Hz/0.01Hz/0.1Hz/0.001kHz/0.01kHz/0.1kHz	$\pm(1.0\%+5)$
	10MHz	0.001MHz	$\pm(3.0\%+5)$
Duty cycle	1~99%	0.1%	$\pm(3.0\%+5)$
Diode measurement	open circuit voltage 2.0V		
Continuity measurement	<50Ω		
Power	2×3V CR2032 batteries		
Dimension (LxWxH)	133×68×18mm		
Weight	178g		

DIGITAL MULTIMETER (WITH JACK INDICATOR LIGHT) CODE 9246-180



- Jack indicator light: jacks flash green to indicate the corresponding jacks for test leads
- NCV detection and judge the strength by light and buzzer
- Self-calibration when power on to ensure accuracy
- LIVE firewire recognition
- Double color backlight (orange backlight prompts high voltage or current: the orange backlight automatically lights up when voltage is higher than 80V or the current is higher than 1A)
- Large range capacitance meter 100mF
- True RMS measurement
- Battery test function
- Max/Min mode
- Data hold
- Low battery indication
- Auto power off
- Safety rating: CAT III 1000V, CAT IV 600V



test leads (included)

SPECIFICATION

Function	Range	Resolution	Accuracy
DC Voltage	600mV/6V/60V/600V/1000V	0.1mV/0.001V/0.01V/0.1V/1V	±(0.5%+3)
AC Voltage	6V/60V/600V/750V	0.001V/0.01V/0.1V/1V	±(0.8%+5)
DC Current	60μA/60mA/600mA/10A	0.01μA/0.01mA/0.1mA/0.01A	±(1.2%+3)
AC Current	60mA/600mA/10A	0.01mA/0.1mA/0.01A	±(1.5%+3)
Resistance	600Ω/6kΩ/60kΩ/600kΩ	0.1Ω/0.001kΩ/0.01kΩ/0.1kΩ	±(1.0%+3)
	6MΩ/60MΩ	0.001MΩ/0.01MΩ	±(1.5%+3)
Capacitance	10nF/100nF/1000nF/10μF/100μF/1000μF	0.001nF/0.01nF/0.1nF/0.001μF/0.01μF/0.1μF	±(4.0%+5)
	10mF/100mF	0.001mF/0.01mF	±(5.0%+5)
Frequency	10Hz/100Hz/1000Hz/10kHz/100kHz/1000kHz	0.001Hz/0.01Hz/0.1Hz/0.001kHz/0.01kHz/0.1kHz	±(1.0%+3)
	10MHz	0.001MHz	±(3.0%+3)
Duty cycle	1~99%	0.1%	±(3.0%+3)
Diode measurement	forward DC current 2.5mA, reverse DC voltage 3.0V		
Continuity measurement	<30Ω		
Power	2x1.5V AA batteries		
Dimension (LxWxH)	188×88×50mm		
Weight	424g		

STANDARD DELIVERY

Main unit	1 pc
Test lead	2 pcs
Battery (AA)	2 pcs

DIGITAL AC/DC CLAMP METER CODE 9315-CF210



test leads (included)



SPECIFICATION

Function	Range	Resolution	Accuracy ("d" is the least reading)
DC Current	40.00A/400.0A	0.01A/0.1A	±(2.0%+5d)
AC Current *	40.00A/400.0A	0.01A/0.1A	±(2.0%+5d)
DC Voltage	400.0mV	0.1mV	±(0.7%+3d)
	4.000V/40.00V/400.0V/600V	0.001V/0.01V/0.1V/1V	±(0.5%+2d)
AC Voltage *	4.000V	0.001V	±(1.0%+5d)
	40.00V/400.0V/600V	0.01V/0.1V/1V	±(0.8%+5d)
AC Voltage frequency	10Hz~60kHz	0.01Hz~0.01kHz	±(0.5%+2d)
Resistance	400.0Ω	0.1Ω	±(1.0%+2d)
	4.000kΩ/40.00kΩ/400.0kΩ	0.001kΩ/0.01kΩ/0.1kΩ	±(0.8%+2d)
	4MΩ/40MΩ	0.001MΩ/0.01MΩ	±(2.5%+5d)
Capacitance	40.00nF/400.0nF/4.000μF/ 40.00μF/400.0μF	0.01nF/0.1nF/0.001μF/ 0.01μF/0.1μF	±(4.0%+5d)
	4.000mF/40.00mF	0.001mF/0.01mF	±10.0%
Frequency	10Hz~10MHz	0.01Hz~0.01MHz	±(0.1%+4d)
Duty cycle	0.1%~99.0%	0.1%	±(3.0%+5d)
Diode test	open circuit voltage: 4V		
Continuity check	<30Ω		
Power supply	2×1.5V AAA batteries		
Dimension (LxWxH)	215×75×37mm		
Weight	235g		

- 4000 counts display
- 28mm jaw opening
- NCV detection with light and sound alarm
- True RMS measurement
- Auto ranging
- REL (zero) function
- Data hold
- Polarity indication
- LCD screen with backlight
- Low battery indication
- Auto power off
- Safety rating: CAT III 300V/CAT II 600V

STANDARD DELIVERY

Main unit	1 pc
Battery (AAA)	2 pcs
Test lead	2 pcs

* AC voltage/current frequency response: 45Hz~400Hz, true RMS display

AC PHASE AND VOLTAGE DETECTOR CODE 9723-400

- Non-contact detection of phase sequence, high and low voltage, wire distinction
- Low battery indication
- Auto power off
- Flashlight



SPECIFICATION

Phase sequence detection	screen display clockwise or counterclockwise
High and low voltage detection	beep: slow~fast backlight: green~red analog bar: low~high
Wire distinction	green backlight indicates neutral wire red backlight indicates live wire
Power supply	2×1.5V AAA batteries
Dimension	157×27×23mm
Weight	32g

DIGITAL VOLTAGE TESTER CODE 9721-250

- Direct AC test (contact): 12-250V
two way display: voltage displays on LCD screen and neon lamp lights up (when voltage>80V)
- Induction AC test (non-contact): 12-250V to detect power source or recognize the phase line, ground line and break point
- Direct DC test (contact): 6-36V instant sense and display
- Work without battery
- Tester tip: CRV material



SPECIFICATION

Range	AC: 12-250V; DC: 6-36V
Neon lamp life	30000 times
Dimension	133×21×19mm
Weight	22g

VOLTAGE TESTER CODE 9722-250

- Tester tip: CRV material



SPECIFICATION

Range	AC: 100-250V
Neon lamp life	30000 times
Dimension	145×Ø15mm
Weight	21g

29

TEMPERATURE AND HUMIDITY MEASUREMENT



Infrared Thermal Imaging Cameras
Page 237



Infrared Thermometers
Page 237-238



Infrared And Penetration Thermometers
Page 239



Thermohygrometers
Page 239-241



Data Loggers For Temperature And Humidity
Page 240

INFRARED THERMAL IMAGING CAMERA (BASIC TYPE) CODE 9132-T400

NON-CONTACT
TEMPERATURE MEASUREMENT



DATA
OUTPUT

IP54
WATERPROOF



front view



- IR/visible/laser indicator
- Trigger button for photo taking
- 2-meter drop test, IP54 protection

STANDARD DELIVERY

Main unit	1 pc
Power supply adapter	1 pc
TYPE-C cable	1 pc
16G TF card	1 pc

SPECIFICATION

IR image	IR resolution	120×90@17μm
	detector type	VOx/7.5~14μm
	frame rate	25Hz/9Hz
	thermal sensitivity/NETD	60mk
	focal length	2.28mm/F1.13
	field of view (FOV)	50°×38°
	spatial resolution (IFOV)	7.6mrad
Visible camera	focus	focus-free
	visible camera resolution	320×240, focus-free
Image display	flashlight	yes
	display	2.4 inch IPS technology TFT display
	display resolution	320×240
Temperature measurement	image model	IR/visible/picture-in-picture
	color palettes	6: white hot, iron red, hot iron, arctic, rainbow 1, rainbow 2
	temperature range	-20~150°C, 100~400°C (auto switching)
	accuracy	±2°C or ±2%, whichever is greater (target temp ≥0°C, ambient temp is 15~30°C)
	measurement spot	center spot
	measurement area	3 (incl. max & min temp)
	auto max & min spot tracking	yes
Image storage	alarm	full screen max & min spot alarm
	storage media	TF card (16G)
	IR image format	full radiometric (JPG) (120x90)
Connections & communications	visible image	yes, 320x240
	USB	type-C, TF card slot
	tripod interface	yes
Power system	mobile APP	yes
	PC IR analysis software	yes
	battery type	rechargeable li ion battery
Environmental parameters	battery operation time	>5 hours
	charging time	internal charge, ≤2.5 hours
	operation temperature	-10~50°C
Environmental parameters	storage temperature	-40~70°C
	protection	IP54, 2-meter drop test
	certification	CE/ROHS/FCC
	dimension (LxWxH)	194×61.5×76mm
	weight	350g

INFRARED THERMOMETER (BASIC TYPE) CODE 0222-C520



- Unit: °C, °F
- Automatic data hold
- MAX/MIN/AVG/DIF mode
- High and low alarm
- Adjustable emissivity
- Low battery display
- Over range indicator
- Automatic power off

STANDARD DELIVERY

Main unit	1 pc
Battery (AAA)	2 pcs

SPECIFICATION

Temperature range	-50°C~500°C/-58°F~932°F
Temperature accuracy	±(2°C+0.1°C/°C) (at -50°C~0°C), ±2.0°C or ±2% (at 0°C~500°C) ±(4°F+0.1°F/°F) (at -58°F~32°F), ±4.0°F or ±2% (at 32°F~932°F)
Temperature resolution	0.1°C/0.2°F
Distance to spot size (D:S)	12:1
Emissivity	0.10~1.00 (adjustable)
Repeatability	±0.5°C or ±0.5%; ±1.0°F or ±0.5%
Response time	≤500ms (95% of reading)
Spectral response	8μm~14μm
Diode laser	output<1mW, wavelength 630nm~670nm, class 2 laser product
Power supply	2×AAA batteries, working time≥6h
Automatic power off	about in 15 seconds
Operation environment	temperature: 0°C~50°C/32°F~122°F; humidity: <90%RH (non-condensing)
Storage environment	temperature: -20°C~60°C/-4°F~140°F; humidity: <90%RH (non-condensing)
Dimension	148×85×46mm
Weight	160g

INFRARED THERMOMETER (STANDARD TYPE) CODE 0213-A500

SPECIFICATION

Temperature range	-20°C~380°C/-4°F~716°F
Temperature accuracy	±2.5°C (at -20°C~20°C), ±2% or ±2.0°C (at 20°C~380°C) ±4.5°F (at -4°F~68°F), ±2% or ±3.6°F (at 68°F~716°F)
Temperature resolution	0.1°C/0.1°F
Distance to spot size (D:S)	12:1
Emissivity	0.95 (fixed)
Repeatability	±1°C/1.8°F
Response time	150ms
Spectral response	8~14μm
Diode laser	output<1mW, wavelength 630~670nm class 2 laser product
Operation temperature	0°C~50°C/32°F~122°F
Operation humidity	10%RH~90%RH
Storage temperature	-10°C~60°C/14°F~140°F
Storage humidity	<80%RH
Power supply	1×9V battery
Dimension	137×73×38mm
Weight	135g



- Unit: °C, °F
- Dual laser sighting
- Negativity display
- Automatic power off
- Automatic data hold
- Over range indicator
- Max/Min display

STANDARD DELIVERY

Main unit	1 pc
Battery	1 pc

INFRARED THERMOMETER (ADVANCED TYPE) CODE 0215-A900

- Ambient temperature, dew point temperature and humidity detection
- Unit: °C, °F
- Circular laser sighting
- Display backlight
- Automatic power off
- Automatic data hold
- Adjustable emissivity
- High and low alarm

SPECIFICATION

Infrared sensor	temperature range	-30°C~800°C/-22°F~1472°F
	temperature resolution	0.1°C 0.1°F (-22°F~1000°F), other range 1°F
	temperature accuracy	±3.0°C (at -30°C~20°C) ±(1% of reading +1)°C (at 20°C~450°C) ±(2% of reading)°C (at 450°C~800°C)
	distance to spot size (D:S)	20:1
	emissivity	adjustable 0.10~1.00
	response time	<150ms
	spectral response	8~14μm
	diode laser	output<1mW, wavelength 630~670nm class 2 laser product
Temperature and humidity sensor	ambient temperature range	0°C~50°C/32°F~122°F
	dew point temperature range	0°C~50°C/32°F~122°F
	temperature resolution	0.1°C/0.1°F
	temperature accuracy	±1.0°C/±1.8°F
	humidity range	0%RH~100%RH
	humidity resolution	0.1%RH
humidity accuracy	±5%RH (20%RH~80%RH), other range ±7%RH	
Automatic power off	about in 10 seconds	
Power supply	1×9V battery	
Dimension	170×45×85mm	
Weight	196g	

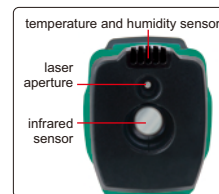

STANDARD DELIVERY

Main unit	1 pc
Battery	1 pc

INFRARED AND PENETRATION THERMOMETER CODE 0321-IT42

IP65
WATERPROOF

VIDEO



- Can measure the surface and inside temperature of objects
- Low battery display
- Display backlight
- High and low alarm
- Automatic data hold (infrared system)
- Automatic power off (infrared system)
- Unit: °C/°F

SPECIFICATION

Infrared system	temperature range	-15°C~280°C/5°F~536°F
	temperature resolution	0.1°C/0.1°F
	temperature accuracy	±3.0°C (at -15°C~20°C), other range ±(1%+1.0)°C ±5.4°F (at 5°F~68°F), other range ±(1%+1.8)°F
	distance to spot size (D:S)	4:1
	emissivity	0.95 (fixed)
Penetration system	spectral response	8~14μm
	temperature range	-40°C~200°C/-40°F~392°F
	temperature resolution	0.1°C/0.1°F
	temperature accuracy	±2.0°C (at -40°C~0°C), other range ±(1%+1.0)°C ±3.6°F (at -40°F~32°F), other range ±(1%+1.8)°F
Repeatability		<1.0°C
Measurement response time		<500ms
Power supply		2×1.5V AAA batteries
Dimension		140×39×24mm
Weight		140g

STANDARD DELIVERY

Main unit	1 pc
Battery (AAA)	2 pcs

DIGITAL THERMOHYGROMETER (PROFESSIONAL TYPE) CODE 9362-TH27

IP50
DUSTPROOF

- Measure humidity, ambient temperature and dew-point temperature
- Max/Min/Average mode
- Alarm function
- IP50 protection grade

SPECIFICATION

Sensor model	NTC thermistor/humidity capacitance/digital sensor
Temperature range	-20°C~70°C/-4°F~158°F
Temperature accuracy	±0.5°C/±0.9°F
Temperature resolution	0.1°C/0.2°F (minimum adjustable unit is 0.2°F in setting mode)
Humidity range	0~100%RH
Humidity accuracy	±5%RH
Humidity resolution	0.1%RH
Sampling interval	5s
Battery	1.5V AAA
Dimension	95×107×18mm
Weight	105g

STANDARD DELIVERY

Main unit	1 pc
Battery (AAA)	1 pc

DATA LOGGER FOR TEMPERATURE AND HUMIDITY (BUILT-IN SENSOR) CODE 0311-3070



IP54
WATERPROOF

DATA
OUTPUT

- Signal acquisition, display, storage, analysis function
- Low power consumption
- Built-in high-precision temperature and humidity sensor
- Software is included

SPECIFICATION

Temperature range	-30°C~70°C/-22°F~158°F
Temperature accuracy	±0.3°C (at 23°C±2°C), other range ±0.5°C ±0.6°F (at 73.4°F±3.6°F), other range ±0.9°F
Temperature resolution	0.1°C/0.2°F
Humidity range	0%RH~100%RH
Humidity accuracy	±3%RH (at 10%RH~85%RH), other range ±5%RH
Humidity resolution	0.1%RH
Memory capacity	10918
Alarm	function: alarm when over high or low limit method: display+buzz+backlight
Sampling interval	2s, 5s, 10s, 30s, 60s, 255s (adjustable)
Logging interval	2 seconds~24 hours (adjustable)
Start with delay	1~120 seconds (adjustable)
Start mode	start immediately/delay start/timing start
End mode	full/FIFO/preset/timing end
Timing start/end	random start/end with format YYMMDD HHMMSS
Interface	USB
Time battery	CR2032
Power supply	3.6V lithium battery (ER14505) or 5~24V DC
Dimensions	123×117×33mm
Weight	260g



stand (included)

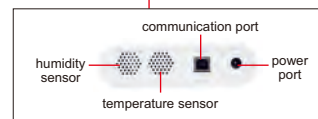

software (included), record and download data to PC software via USB cable

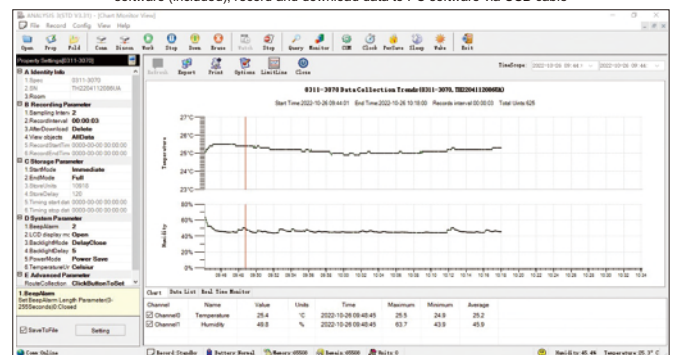

STANDARD DELIVERY

Main unit	1 pc
Software and USB cable	1 pc
Time battery	1 pc
Lithium battery	1 pc

THERMOHYGROMETER CODE 0310-H26

- Measure humidity, ambient temperature, dew point temperature and wet bulb temperature
- Min/Max, data hold function
- Bluetooth 4.0
- Auto power off
- Supplied with APP for Apple and Android



STANDARD DELIVERY

Main unit	1 pc
Battery	1 pc

SPECIFICATION

Function	Measuring range	Resolution	Accuracy
Ambient temperature	0°C~50°C 32°F~122°F	0.1°C/0.1°F	±1.0°C/±1.8°F
Wet bulb temperature	0°C~50°C 32°F~122°F		
Dew point temperature	0°C~50°C 32°F~122°F		
Humidity	0%RH~80%RH	0.1%RH	±5.0%RH
Auto power off	30 minutes		
Data port	Bluetooth 4.0		
Power supply	9V battery		
Dimension	204×54×36mm		
Weight	172g		

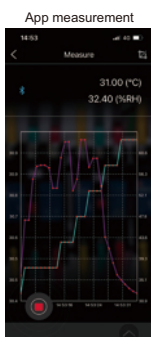

THERMOHYGROMETER (EXTERNAL SENSOR) CODE 0313-TH48



- External sensor, 3m cable
- Time/temperature/humidity display
- Temperature and humidity upper and lower limit alarm function
- Unit: °C/°F
- Low battery warning

SPECIFICATION

Temperature range	-40°C~80°C/-40°F~176°F
Temperature accuracy	±0.5°C (at -20°C~60°C), ±1.0°C (at 60°C~80°C), ±2°C (at -40°C~-20°C), ±2°F (at -20°F~176°F), ±3°F (at -40°F~-20°F)
Temperature resolution	0.1°C (at -20°C~80°C), other range 1°C 0.1°F (at -20°F~100°F), other range 1°F
Humidity range	0%RH~99.9%RH
Humidity accuracy	±5%RH (at 10°C~60°C), other range ±7% ±5%RH (at 50°F~140°F), other range ±7%
Humidity resolution	0.1%RH
Sensitivity attenuation value	temperature: <0.1°C/year (<0.2°F/year) humidity: <1%RH/year
Sampling interval	5 seconds
Power supply	built-in rechargeable lithium battery (USB 5V charging) working time at least one month
Dimension	88×88×21mm
Weight	174g

STANDARD DELIVERY

Main unit	1 pc
USB charging cable	1 pc

K-TYPE THERMOCOUPLE THERMOMETER (ECONOMIC TYPE) CODE 0320-K230



- Contact K-type thermocouple
- Unit: °C/°F
- Data hold function
- Low battery display
- Display backlight

SPECIFICATION

Temperature range	-50°C~200°C/-58°F~392°F
Temperature accuracy	±2.0°C/±3.6°F
Temperature resolution	0.1°C (at -50°C~199.9°C), 1°C (at -50°C~200°C) 0.1°F (at -58°F~199.9°F), 1°F (at -58°F~392°F)
Sampling rate	2.5 times/sec
Power supply	3×3V CR2450 batteries (for 300 hours working)
Operation voltage	6.8V~10V
Dimension	149×76×34mm
Weight	220g

STANDARD DELIVERY

Main unit	1 pc
Thermocouple (K-type)	1 pc
CR2450 battery	3 pcs

THERMOHYGROMETER (ECONOMIC TYPE) CODE 0312-TH50



- Environment comfort display:
COMFORT, WET, DRY
- Time/temperature/humidity display
- Highest/lowest temperature and
humidity memory function
- Alarm clock function
- Unit: °C, °F

STANDARD DELIVERY

Main unit	1 pc
Battery	1 pc

SPECIFICATION

Temperature range	0°C~50°C/32°F~122°F
Temperature accuracy	±1.0°C (at 5°C~40°C), other range ±1.5°C ±1.8°F (at 41°F~104°F), other range ±2.7°F
Temperature resolution	0.1°C/0.1°F
Humidity range	10%RH~90%RH
Humidity accuracy	±5%RH (at 40%RH~80%RH), other range ±8%RH
Humidity resolution	1%RH
Power supply	1×AAA 1.5V battery
Dimension	108×60×15mm
Weight	74g



Surface Profile Measuring Machines
Page 243-244



Roughness Measuring Machines
Page 245

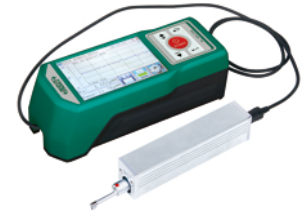

Roughness Testers
Page 246-250



Surface Roughness Specimen Sets
Page 250

SURFACE PROFILE MEASURING MACHINE CODE SPM-1000

- Software is included, for surface profile measurement and data output
- Probe compensation
- Output as format txt, csv, etc.
- Large range design, the leverage ratio is 1:2.2, maintain the original accuracy of the sensor
- The overall structure of the Z-axis sensor does not have any elastic components, ensuring the measuring force is constant regardless the position of probe

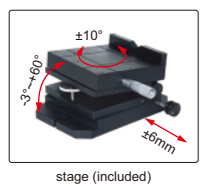
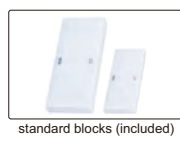
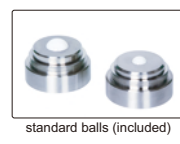
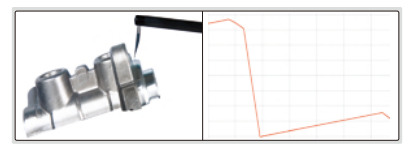
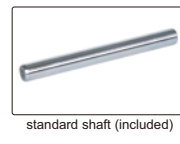
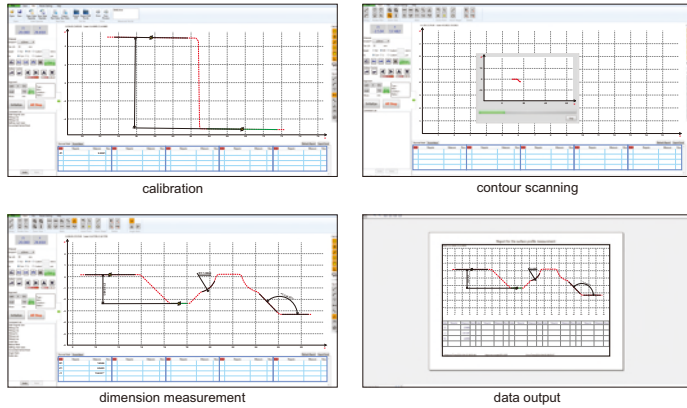
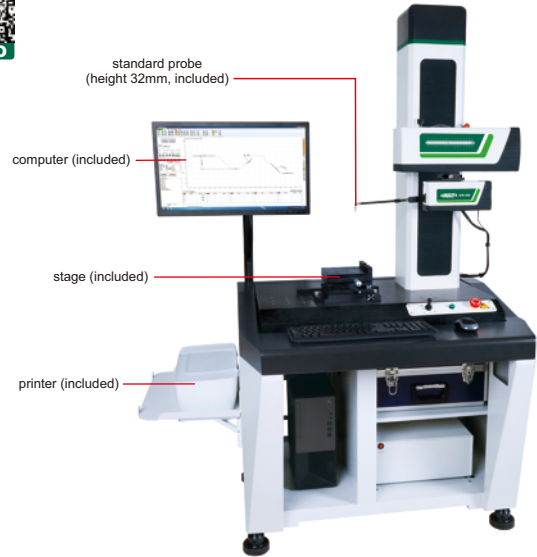

SPECIFICATION

X axis measuring range	140mm
X axis resolution	0.2μm
X axis straightness	0.8μm/100mm
X axis moving speed	0.1~10mm/s
Z axis measuring range	±20mm
Z axis resolution	0.05μm
Z axis moving speed	0.5~10mm/s
Linear accuracy	±(1.5+ 0.2H)μm, H is measuring height in mm
Angular measuring accuracy	±2'
Arc measuring accuracy	±(2+R/8)μm, R is 2~10mm standard ball
Radius of probe tip	25μm
Moving direction	backward
Measuring force	6.86~9.8mN
Measuring unit	mm/inch
Traceable angle	72° (upward), 87° (downward)
Drive mode	motor
Travel of Z axis	430mm
Dimension (L×W×H)	1200×700×1780mm
Power supply	220±5%V, 50Hz
Weight	320kg

STANDARD DELIVERY

Main unit	1 pc
Standard probe and arm	1 pc of each
Standard block	2 pcs
Standard ball	2 pcs
Standard shaft	1 pc
Stage	1 pc
Vise	1 pc
Measuring arm	1 pc
Computer	1 pc
Measurement software	1 pc
Printer	1 pc
Installation tools	1 set

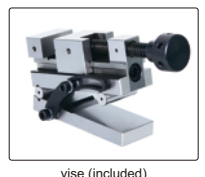

OPTIONAL ACCESSORY

Probe	refer to details
-------	------------------

SPECIFICATION OF PROFILE PROBES

Unit: mm

<p>chisel stylus</p> <p>code SPM-1000-T01 (H=32mm, included) code SPM-1000-T02 (H=48mm, optional) code SPM-1000-T03 (H=68mm, optional)</p>	<p>cone stylus</p> <p>code SPM-1000-Z01 (H=32mm, optional) code SPM-1000-Z02 (H=48mm, optional) code SPM-1000-Z03 (H=68mm, optional)</p>	<p>ball stylus</p> <p>code SPM-1000-R01 (H=32mm, optional) code SPM-1000-R02 (H=48mm, optional) code SPM-1000-R03 (H=68mm, optional)</p>	<p>standard arm, code SPM-1000-SP (included), stylus is not included</p>
<p>probe for small holes, code SPM-1000-SBP (optional), stylus is included</p> <p>measure the contour of holes with diameter>Ø8mm</p>		<p>transverse probe, code SPM-1000-LP (optional), stylus is included</p> <p>measure the contour of holes in radial direction</p>	

ROUGHNESS AND PROFILE MEASURING MACHINE CODE SPM-2000



- Software is included, for measurement and data output
- Profile sensor with low noise
- Wide range roughness sensor without skid
- Meet ISO1997, ISO1984, BS1988, DIN1990, ASME1995, JIS1982, JIS1994 standards
- 65 roughness parameters

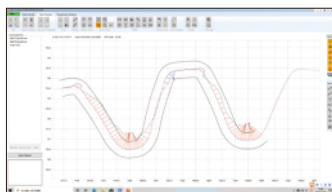

CAD profile comparison

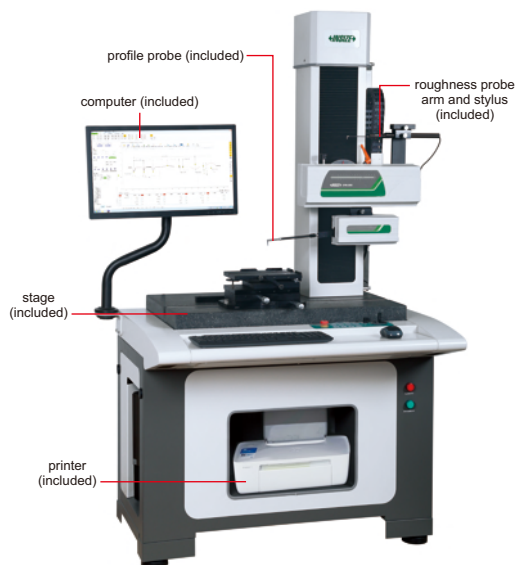

PROFILE MEASUREMENT SPECIFICATION

X axis measuring range	140mm
X axis resolution	0.2μm
X axis traverse speed	0.05~15mm/s
Z axis measuring range	50mm
Z axis resolution	0.05μm
Z axis traverse speed	0.2~15mm/s
Straightness	0.5μm/100mm
Linear accuracy	±(0.8+ 0.15H)μm, H is measuring height in mm
Angular measuring accuracy	±1'
Arc measuring accuracy	±(1.5+R/12)μm, R is 2~10mm standard ball
Measuring unit	μm/μin
Measuring speed	0.05~1mm/s
Traceable angle	72° (upward), 88° (downward)
Travel of Z axis	430mm
Power supply	220±5%V, 50Hz
Dimension (L×W×H)	1400×850×1780mm
Weight	350kg

ROUGHNESS MEASUREMENT SPECIFICATION

Roughness parameters	Ra, Rp, Rv, Rz, Rz (JIS), R3z, Rz (DIN), Rzj, Rmax, Rc, Rt, Rq, Rsk, Rku, Rsm, Rs, PΔq, Rk, Rpk, Rvk, Mr1, Mr2, Rmr
Waviness parameters	Wa, Wt, Wp, Wv, Wz, Wq, Wsm, Wsk, Wku, Wmr
Primary profile parameters	Pa, Pt, Pp, Pv, Pz, Pq, Psm, Psk, Pku, Pmr
Measuring range	±420μm
Resolution	0.001μm
Linear accuracy	±(5nm+2.8%)
Probe radius/angle	5μm/90°
Cut off	0.025/0.08/0.25/0.8/2.5/8mm
Number of cut-offs	2~7
Measuring unit	μm
Measuring speed	0.05~0.25mm/s

STANDARD DELIVERY

Main unit	1 pc
Calibration block	1 set
Roughness probe arm	1 pc
Roughness stylus	1 pc
Profile probe arm	1 pc
Profile chisel stylus	1 pc
Stage	1 set
Vise	1 set
Computer	1 pc
Software	1 set
Printer	1 pc
Installation tools	1 set

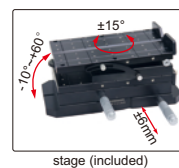

stage (included)

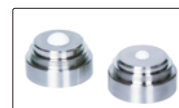

standard balls (included)



standard shaft (included)



vise (included)



standard blocks (included)

OPTIONAL ACCESSORY

Probe	refer to details
-------	------------------

SPECIFICATION OF ROUGHNESS PROBE

Unit: mm

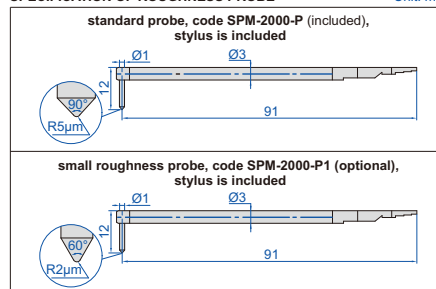

SPECIFICATION OF PROFILE PROBES

Unit: mm

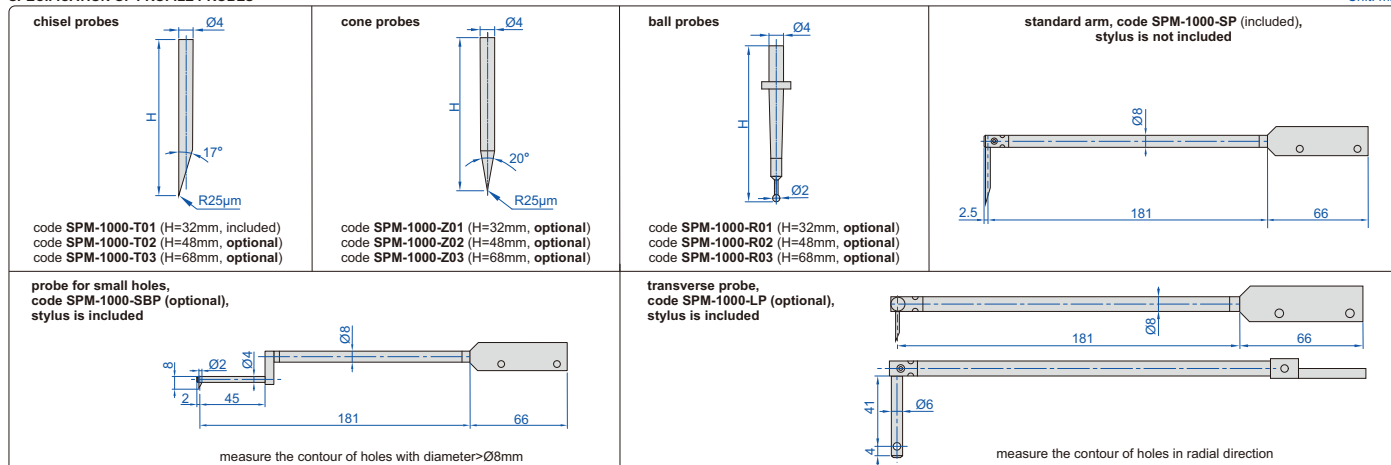

ROUGHNESS MEASURING MACHINE CODE SPM-4000

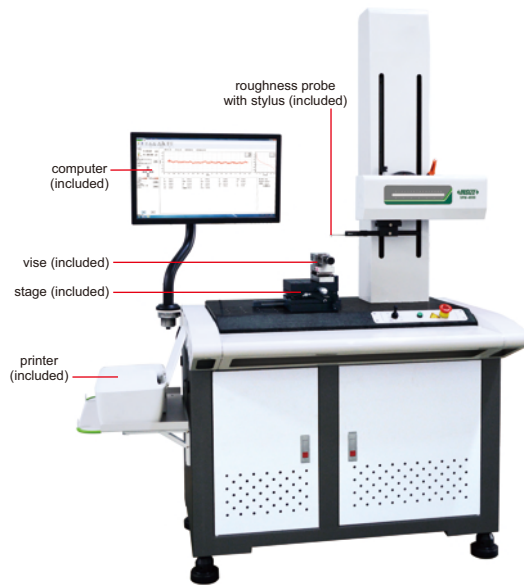

- Skidless probe
- Hundreds of parameters can be evaluated, such as roughness profile, waviness profile, primary profile, etc.
- Software is included, for measurement and data output

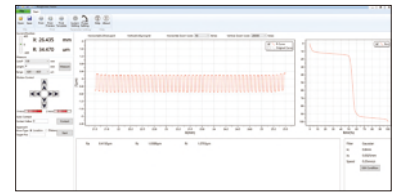

calibration

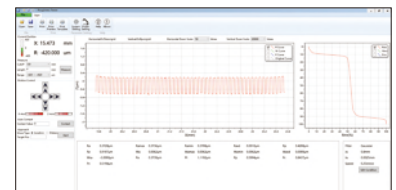

parameter measurement

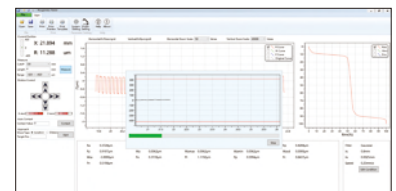

measurement

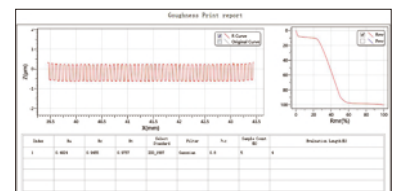

data output



calibration block (included)



vise (included)

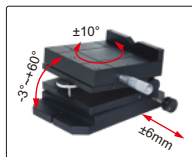

stage (included)

SPECIFICATION

Roughness parameters	Ra, Rp, Rv, Rz, Rz (JIS), R3z, Rz (DIN), Rzj, Rmax, Rc, Rt, Rq, Rsk, Rku, Rsm, Rs, RΔq, Rk, Rpk, Rvk, Mr1, Mr2, Rmr
Waviness parameters	Wa, Wt, Wp, Wv, Wz, Wq, Wsm, Wsk, Wku, Wmr
Primary profile parameters	Pa, Pt, Pp, Pv, Pz, Pq, Psm, Psk, Pku, Pmr
X axis measuring range	100mm
X axis resolution	0.2μm
X axis straightness	0.5μm/100mm
X axis moving speed	0.1~10mm/s
Z axis measuring range	±420μm
Z axis resolution	0.001μm
Z axis linear accuracy	±(7nm+3.5%)
Z axis moving speed	0.5~10mm/s
Z axis repeatability	1δ≤2nm
Radius/angle of stylus	5μm/90°
Cut off length	0.025/0.08/0.25/0.8/2.5/8mm
Number of cut-offs	2~7
Measuring unit	μm
Drive mode	motor
Travel of Z axis	320mm
Dimension (LxWxH)	1200×700×1780mm
Power supply	220±5%V, 50Hz
Weight	320kg

STANDARD DELIVERY

Main unit	1 pc
Roughness probe (with stylus)	1 pc
Calibration block	1 pc
Stage	1 pc
Vise	1 pc
Computer	1 pc
Software	1 set
Printer	1 pc
Installation tools	1 set

SPECIFICATION OF ROUGHNESS PROBE

Unit: mm

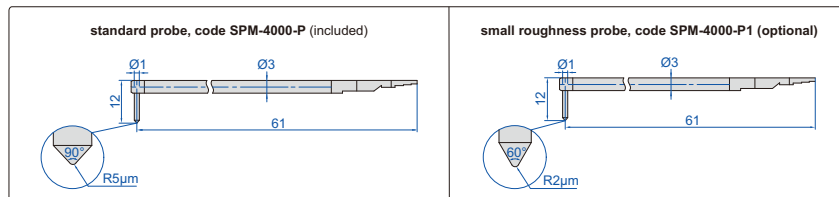

OPTIONAL ACCESSORY

Small roughness probe	refer to details
-----------------------	------------------

ROUGHNESS TESTER CODE ISR-C002

CAN BE OPERATED BY
MOBILE PHONES OR COMPUTERS

BLUETOOTH

DATA
OUTPUT

- Roughness tester can be operated by mobile phones (only Android system) or computers
- Data can be sent to Excel by connecting to computers via bluetooth or SPC cable
- Support bluetooth printer
- 21 roughness parameters
- Display roughness value, profile and curve
- Memory of maximum 100 results
- Automatic power off



software flash disk
(included)



probe cover (included)



adjustable stand (included)



bluetooth printer (optional)



light duty test stand (optional)



heavy duty test stand (optional)



operate roughness tester by computers

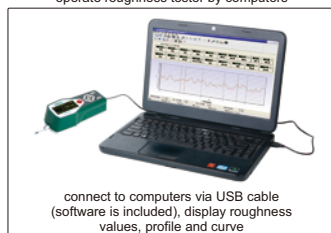

operate roughness tester by mobile phones



Unit: mm

extension rod (optional), code ISR-C002-ER

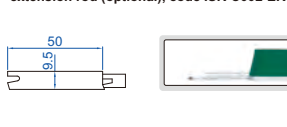

transverse rod (optional), code ISR-C002-TR



deep groove probe (optional), code ISR-C002-DGP

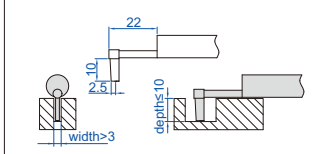

tiny hole probe (optional), code ISR-C002-SBP

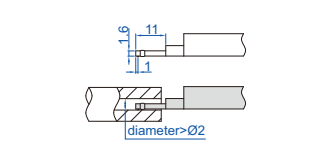

data can be sent to Excel by connecting to computer via bluetooth or SPC cable

via bluetooth

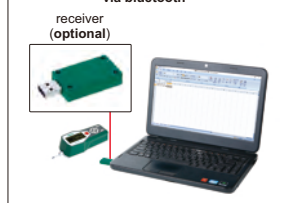

SPC cable (optional)



via SPC cable



deep groove probe (optional), code ISR-C002-DGP1

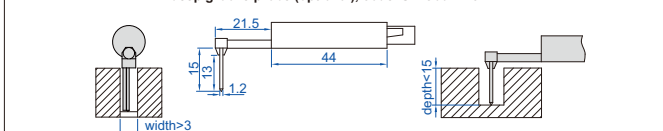

SPECIFICATION

Parameters	Ra, Rz, Rq, Rv, Rp, RS, R3z, R3y, Rt, Rz (JIS), Rk, Rku, Rsm, Rpc, Rpk, Rvk, Rsk, Mr1, Mr2, Ry (JIS), Rmax	
Range	320μm (-160μm~160μm)	
Accuracy	±10%	
Resolution (Ra)	0.001μm	
Probe	type	inductive
	stylus radius/angle	5μm/90°
	stylus material	diamond
Measuring force	4mN	
Measuring unit	μm/μin	
Cut off	0.25/0.8/2.5mm	
Number of cut-off	1 to 5	
Moving speed	0.5mm/s, 1mm/s	
Memory	100 measurement results	
Output	bluetooth and USB	
Power	built-in rechargeable battery	
Dimension (L×W×H)	141×55×40mm	
Weight	400g	

STANDARD DELIVERY

Main unit	1 pc
Standard probe	1 pc
Calibration block and support	1 pc of each
Adjustable stand	1 pc
Probe cover	1 pc
Software and USB cable	1 pc
AC/DC adapter	1 pc

OPTIONAL ACCESSORY

Extension rod	ISR-C002-ER
Transverse rod	ISR-C002-TR
Tiny hole probe	ISR-C002-SBP
Deep groove probe	ISR-C002-DGP
Deep groove probe	ISR-C002-DGP1*
Light duty test stand	ISR-C002-STAND1
Heavy duty test stand	ISR-C002-STAND
Bluetooth printer	ISR-C002-PRINTER
Receiver	ISR-C300-RECEIVER
SPC cable	ISR-C300-SPC

*Need to be delivered with roughness tester ISR-C002

screen display

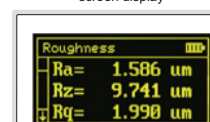

measurement result

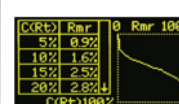

Rmr analysis

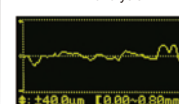

roughness profile

ROUGHNESS TESTER (SEPARABLE TYPE) CODE ISR-C300

CAN BE OPERATED BY
MOBILE PHONES OR COMPUTERS

TOUCH SCREEN

BLUETOOTH

DATA
OUTPUT

**POPULAR
MODEL**



- Roughness tester can be operated by mobile phone (only Android system) or computers
- Data can be sent to Excel by connecting to computers via bluetooth or SPC cable
- Support bluetooth printer
- 22 roughness parameters
- Meet ISO, DIN, ANSI, JIS standards
- Display roughness values, profile and curve
- Memory of maximum 100 data and waveform
- Built-in lithium battery, working time more than 50 hours
- Touch screen
- Automatic power off

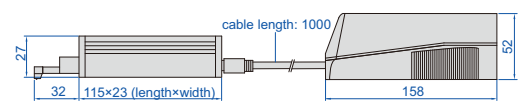
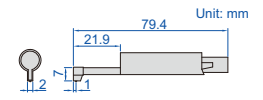

operate roughness tester by computers

connect to computers via USB cable (software is included), display roughness values, profile and curve

operate roughness tester by mobile phones

connect to mobile phones via bluetooth (only Android system), display roughness values, profile and curve

software flash disk (included)

optional probes

<p>extension rod (optional), code ISR-C002-ER</p>	<p>small hole probe (optional), code ISR-C002-PROBE</p>	<p>tiny hole probe (optional), code ISR-C002-SBP</p>
<p>2µm/60° probe (optional), code ISR-C300-P2UM (When Ra<0.5µm, the accuracy with this probe is better)</p>	<p>deep groove probe (optional), code ISR-C002-DGP</p>	<p>deep groove probe (optional), code ISR-C002-DGP1</p>

magnetic stand adapter (included)

can be installed on magnetic stands

height gage adapter (optional)

can be installed on height gages

NOTE: Please check whether the adapter can fit your height gages. When using INSIZE height gages, please use the dial test indicator holder of height gages

SPECIFICATION

Parameters		Ra, Rz, Rq, Rv, Rp, Rs, R3z, R3y, Rt, Rc, Rz (JIS), Rk, Rku, Rsm, Rpc, Rpk, Rvk, Rsk, Mr1, Mr2, Ry, Rmax
Range	X axis	17.5mm
	Z axis	320µm (-160µm~160µm)
Accuracy		±10%
Resolution (Ra)		0.001µm
Probe	type	inductive
	stylus radius/angle	5µm/90°
	stylus material	diamond
Measuring force		4mN
Measuring unit		µm/µin
Cut off		0.25/0.8/2.5mm
Number of cut-offs		1~5
Moving speed		0.135mm/s, 0.5mm/s, 1mm/s
Memory		100 measurement results
Output		bluetooth and USB
Power		built-in rechargeable battery
Dimension (L×W×H)		158×64×52mm
Weight		400g

roughness tester screen display

measurement result roughness profile Rmr analysis

data can be sent to Excel by connecting to computer via bluetooth or SPC cable

<p>via bluetooth</p> <p>receiver (optional)</p>	<p>receiver (optional)</p> <p>SPC cable (optional)</p>	<p>via SPC cable</p>
---	--	----------------------

To be continued

Continued from previous page

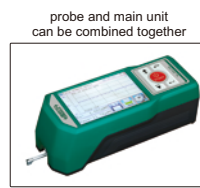
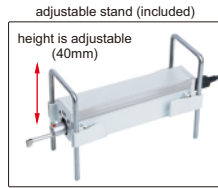

STANDARD DELIVERY

Main unit	1 pc
Standard probe	1 pc
Calibration block and support	1 pc of each
Connecting cable (long and short)	1 pc of each
Magnetic stand adapter	1 pc
Adjustable stand	1 pc
Touch pen	1 pc
Software and USB cable	1 pc
AC/DC adapter	1 pc

OPTIONAL ACCESSORY

Extension rod	ISR-C002-ER
Small hole probe	ISR-C002-PROBE
Tiny hole probe	ISR-C002-SBP
Deep groove probe	ISR-C002-DGP
Deep groove probe	ISR-C002-DGP1*
2µm/60° probe	ISR-C300-P2UM
Bluetooth printer	ISR-C002-PRINTER
Height gage adapter	ISR-C300-LB1
Receiver	ISR-C300-RECEIVER
SPC cable	ISR-C300-SPC
Support for flat surface	ISR-C300-COVER1
Support for cylindrical surface	ISR-C300-COVER2
Light duty test stand	ISR-C002-STAND1
Heavy duty test stand	ISR-C002-STAND

*Need to be delivered with roughness tester **ISR-C300**

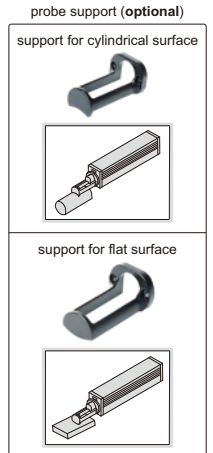

**ROUGHNESS TESTER
CODE ISR-T120**

DATA OUTPUT

BLUETOOTH

TOUCH SCREEN

CAN BE OPERATED BY
MOBILE PHONES OR COMPUTERS

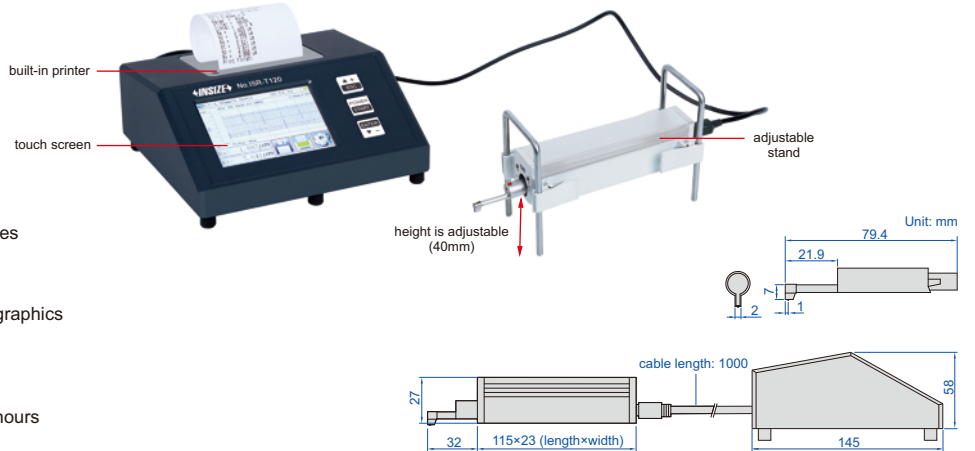

- Roughness tester can be operated by mobile phones (only Android system) or computers
- Data can be sent to Excel by connecting to computers via bluetooth or SPC cable
- Built-in printer can print measurement results and graphics
- 22 roughness parameters
- Meet ISO, DIN, ANSI, JIS standards
- Display roughness values, profile and curve
- Memory of maximum 100 data and waveform
- Built-in lithium battery, working time more than 50 hours
- Automatic power off

operate roughness tester by mobile phones



operate roughness tester by computers

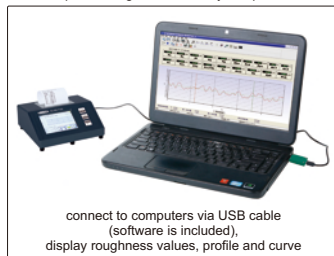

data can be sent to Excel by connecting to computer via bluetooth or SPC cable

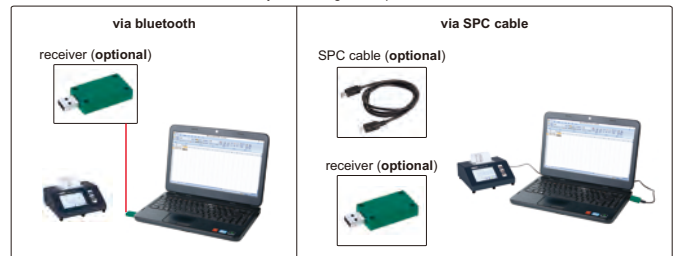

To be continued

Continued from previous page

probe support (optional)

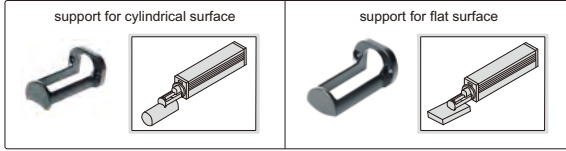

roughness tester screen display

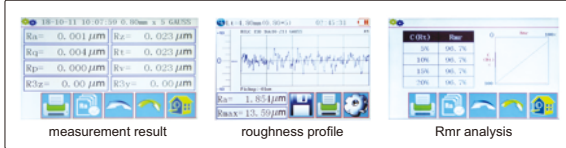

light duty test stand (optional)



heavy duty test stand (optional)



magnetic stand adapter (included)



height gage adapter (optional)

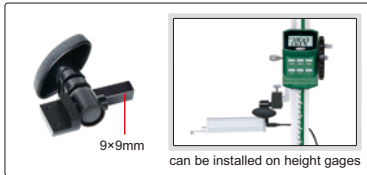

NOTE: Please check whether the adapter can fit your height gages. When using INSIZE height gages, please use the dial test indicator holder of height gages

optional probes

Unit: mm

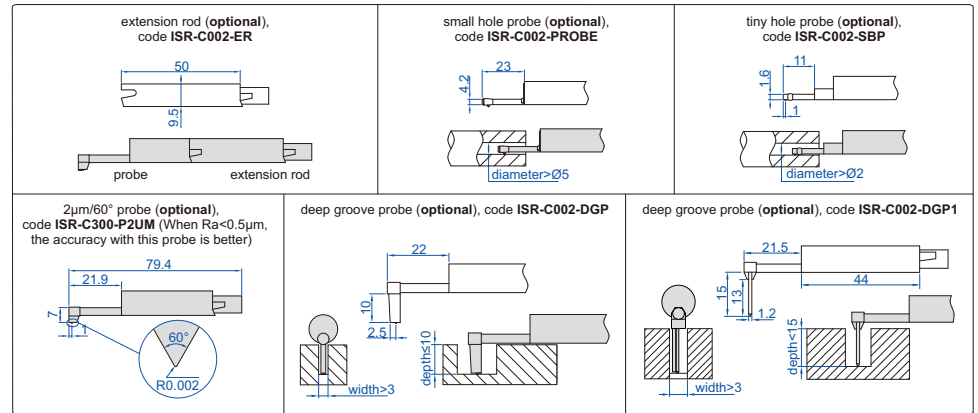

SPECIFICATION

Parameters	Ra, Rz, Rq, Rv, Rp, Rs, R3z, R3y, Rt, Rc, Rz (JIS), Rk, Rku, Rsm, Rpc, Rpk, Rvk, Rsk, Mr1, Mr2, Ry, Rmax	
Range	X axis	17.5mm
	Z axis	640µm (-320µm~320µm)
Accuracy	±10%	
Resolution (Ra)	0.001µm	
Probe	type	inductive
	stylus radius/angle	5µm/90°
	stylus material	diamond
Measuring force	4mN	
Measuring unit	µm/µin	
Cut off	0.25/0.8/2.5mm	
Number of cut-offs	1~5	
Traverse speed	0.135mm/s, 0.5mm/s, 1mm/s	
Memory	100 measurement results	
Output	bluetooth and USB	
Power	built-in rechargeable battery	
Dimension (L×W×H)	155×145×58mm	
Weight	1000g	

STANDARD DELIVERY

Main unit	1 pc
Standard probe	1 pc
Calibration block and support	1 pc of each
Magnetic stand adapter	1 pc
Adjustable stand	1 pc
Touch pen	1 pc
Software and USB cable	1 pc
AC/DC adapter	1 pc

OPTIONAL ACCESSORY

Extension rod	ISR-C002-ER
Small hole probe	ISR-C002-PROBE
Tiny hole probe	ISR-C002-SBP
2µm/60° probe	ISR-C300-P2UM
Deep groove probe	ISR-C002-DGP
Deep groove probe	ISR-C002-DGP1 *
Height gage adapter	ISR-C300-LB1
Receiver	ISR-C300-RECEIVER
SPC cable	ISR-C300-SPC
Support for flat surface	ISR-C300-COVER1
Support for cylindrical surface	ISR-C300-COVER2
Light duty test stand	ISR-C002-STAND1
Heavy duty test stand	ISR-C002-STAND

*Need to be delivered with roughness tester ISR-T120

ROUGHNESS TESTER (BASIC TYPE) CODE ISR-C003

ATTENTION: THIS ROUGHNESS TESTER IS NOT SUITABLE FOR ROUGH TURNING, MILLING AND PLANING WORKPIECES



- Unit: μm , μin
- Automatic power off

SPECIFICATION

Parameters	Ra, Rz, Rq, Rt	
Range	Ra, Rq: 0.05~15 μm Rz, Rt: 0.1~50 μm	
Accuracy	$\pm 10\%$	
Resolution (Ra)	0.01 μm	
Probe	type	piezoelectric
	stylus radius/angle	10 $\mu\text{m}/90^\circ$
	stylus material	diamond
Measuring force	5mN	
Measuring unit	$\mu\text{m}/\mu\text{in}$	
Cut off	0.25/0.8/2.5mm	
Evaluation length	1.25mm for cut off 0.25mm 4mm for cut off 0.8mm 5mm for cut off 2.5mm	
Moving speed	0.75mm/s	
Power	built-in rechargeable battery	
Dimension (L×W×H)	106×70×24mm	
Weight	200g	

fixture for small shafts (optional)

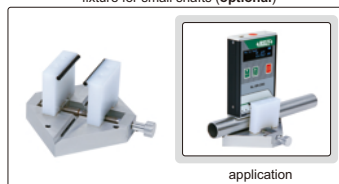

calibration block (included)



STANDARD DELIVERY

Main unit	1 pc
Calibration block	1 pc
AC/DC adapter	1 pc

OPTIONAL ACCESSORY

Fixture for small shafts	ISR-C003-FIXTURE
--------------------------	------------------

SURFACE ROUGHNESS SPECIMEN SET CODE ISR-CS130-W

INSIZE PLUS
MADE IN EUROPE



- For checking, identifying and specifying the roughness by symbol
- Rust-proof, made of pure Nickel

Machining method	Roughness (Ra) *	Roughness (Rz) *	Quantity
Flat lapping	0.05, 0.1, 0.2 μm	0.55, 1, 1.6 μm	3 pcs
	2, 4, 8 μm		
Reaming	0.4, 0.8, 1.6 μm	3, 6, 10 μm	3 pcs
	16, 32, 63 μm		
Plain grinding	0.05, 0.1, 0.2, 0.4, 0.8, 1.6 μm	0.55, 1, 1.6, 3, 6, 10 μm	6 pcs
	2, 4, 8, 16, 32, 63 μm		
Horizontal milling	0.4, 0.8, 1.6, 3.2, 6.3, 12.5 μm	2.5, 4, 8, 16, 32, 50 μm	6 pcs
	16, 32, 63, 125, 250, 500 μm		
Vertical milling	0.4, 0.8, 1.6, 3.2, 6.3, 12.5 μm	2.5, 4, 8, 16, 32, 50 μm	6 pcs
	16, 32, 63, 125, 250, 500 μm		
Turning	0.4, 0.8, 1.6, 3.2, 6.3, 12.5 μm	2.5, 4, 8, 16, 32, 50 μm	6 pcs
	16, 32, 63, 125, 250, 500 μm		

* The actual value is the value to be calibrated



Rockwell Hardness Testers
Page 252-255



Micro-Vickers Hardness Testers
Page 256-257



Vickers Hardness Testers
Page 258-259



Brinell Hardness Testers
Page 260-261



Brinell/Rockwell/Vickers Hardness Testers
Page 262



Portable Leeb Hardness Testers
Page 263-267



Portable Rockwell Hardness Testers
Page 267



Hydraulic Brinell Hardness Testers
Page 268



Aluminum Hardness Testers
Page 268-269



Aluminum Hardness Testers
Page 269



Shore Durometers
Page 269-270



Hardness Test Blocks
Page 271

MOTORIZED DIGITAL ROCKWELL HARDNESS TESTER CODE HDT-RT151

TOUCH SCREEN

BUILT-IN BLUETOOTH

FORCE LOADING BY ELECTRIC MOTOR (WITHOUT WEIGHTS)



POPULAR MODEL

INSPECTION CERTIFICATE

- Electronic loading test force, high accuracy of force value, and stable measurement value
- Touch screen operation and display, simple operation interface
- 15 types of Rockwell hardness scales can be tested
- Convertible to various hardness standards such as HB and HV
- 500 sets of storage
- With correction function, the hardness value can be corrected based on the size of the cylinders
- According to ISO 6508

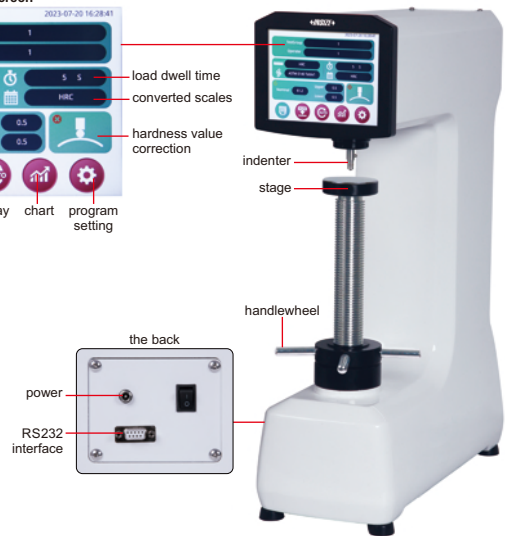
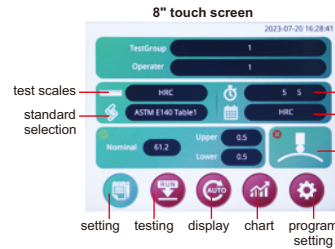

Ø58mm flat anvil (included)



Ø150mm flat anvil (included)



V-type anvil (included)



bluetooth printer (included)

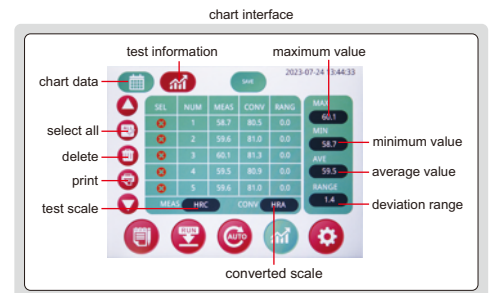
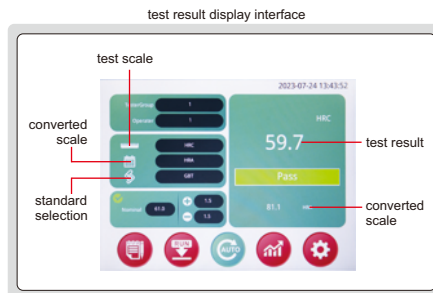
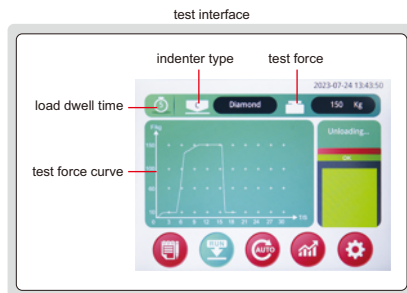

SPECIFICATION

Measurement range		20~88HRA, 20~100HRB, 20~70HRC
Hardness scale	with indenter included	HRA, HRB, HRC, HRD, HRF, HRG
	with optional indenter	HRE, HRH, HRK, HRL, HRM, HRP, HRR, HRS, HRV
Preliminary test force		98N/10kgf
Test force		588N (60kg), 980N (100kg), 1471N (150kg)
Stage elevation		manual
Load control		automatic (load/dwell/unload)
Load dwell time		2~60 second
Resolution		0.1HR
Max. workpiece height		230mm
Max. testing width		170mm
Power supply		100~240V, 50/60Hz
Dimension		475×200×700mm
Weight		70kg

STANDARD DELIVERY

Main unit	1 pc
Diamond indenter	1 pc
Ø1.5875mm carbide ball indenter	1 pc
Ø58mm flat anvil	1 pc
Ø150mm flat anvil	1 pc
V-type anvil	1 pc
Hardness test block HRC20~30	1 pc
Hardness test block HRC40~50	1 pc
Hardness test block HRC60~70	1 pc
Hardness test block HRB80~100	1 pc
Hardness test block HRA80~90	1 pc
Bluetooth printer	1 pc
Anti-dust cover	1 pc

OPTIONAL ACCESSORY

Hardness test block HRC20~30	HDT-B-HRC1
Hardness test block HRC60~70	HDT-B-HRC3
Hardness test block HRB80~100	HDT-B-HRB
Hardness test block HR15N78~88	HDT-B-HR15N2
Hardness test block HR30N55~73	HDT-B-HR30N2
Hardness test block HR30T73~82	HDT-B-HR30T

MOTORIZED DIGITAL ROCKWELL HARDNESS TESTER CODE ISH-MRD200

INSPECTION
CERTIFICATE

DATA
OUTPUT

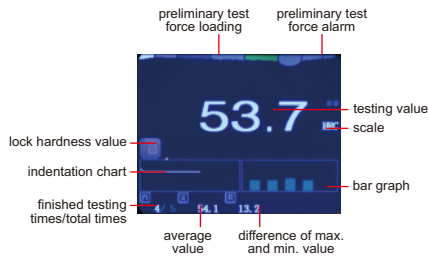

software flash disk (included)

- Tolerance testing
- Set testing times (2~10) to have average value and the difference of max. and min. value
- Convert to other Rockwell scales, HV or HB
- Memory of 500 testing values for browsing and output
- Testing value can be sent to wireless printer automatically
- Calibration function compensates the testing value for high accuracy
- The hardness value of soft materials like plastic is not stable, the lock function can obtain the value automatically
- Display unit is automatic power off
- According to ISO 6508
- Keyboard signal, can be transmitted to Excel

SPECIFICATION

Hardness scale	HRA, HRB, HRC, HRD, HRF, HRG (with standard indenters) HRE, HRH, HRK (with optional indenter)
Preliminary test force	98N
Test force	588N, 980N, 1471N
Stage elevation	manual
Load control	automatic (load/dwell/unload)
Load dwell time	1~99 second
Resolution	0.1HR
Output	wireless and USB
Memory	500
Max. workpiece height	170mm
Max. testing width	165mm (from the center of indenter to the wall of main body)
Power supply of the display unit	built-in rechargeable battery
Power supply	220V, 50/60Hz
Dimension	520×160×700mm
Weight	60kg



Ø60mm flat anvil (included)



Ø150mm flat anvil (included)



wireless printer (optional)



small V-type anvil (optional) for cylinders with diameter Ø2-4mm



V-type anvil (included) for cylinders with diameter Ø4-60mm



desk (optional)

STANDARD DELIVERY

Main unit	1 pc
Ø60mm flat anvil	1 pc
Ø150mm flat anvil	1 pc
V-type anvil	1 pc
Diamond indenter	1 pc
Ø1.5875mm carbide ball indenter	1 pc
Hardness test block HRB88~95	1 pc
Hardness test block HRC60~65	1 pc
Hardness test block HRC20~30	1 pc
Anti-dust cover	1 pc
Software and USB cable	1 pc
AC/DC adapter	1 pc

OPTIONAL ACCESSORY

Wireless printer	ISH-DS-PRINTER
Ø3.175mm carbide ball indenter	ISH-EHK-INDENTER
Hardness test block HRB88~100	HDT-B-HRB
Hardness test block HRC60~70	HDT-B-HRC3
Hardness test block HRC20~30	HDT-B-HRC1
Small V-type anvil	ISH-SMALLANVIL
Desk	HDT-DESK

MANUAL DIGITAL ROCKWELL HARDNESS TESTER CODE ISH-RD200

DATA
OUTPUT

INSPECTION
CERTIFICATE

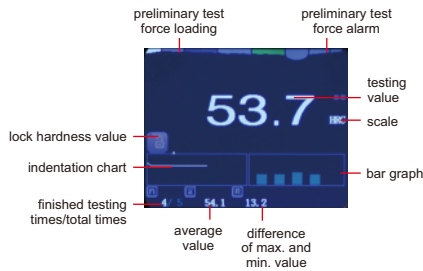

- Tolerance testing
- Set testing times (2~10) to have average value and the difference of max. and min. value
- Convert to other Rockwell scales, HV or HB
- Memory of 500 testing values for browsing and output
- Testing value can be sent to wireless printer automatically
- Calibration function compensates the testing value for high accuracy
- The hardness value of soft materials like plastic is not stable, the lock function can obtain the value automatically
- Automatic power off
- According to ISO 6508
- Keyboard signal, can be transmitted to Excel



software flash disk (included)



Ø60mm flat anvil (included)



Ø150mm flat anvil (included)



V-type anvil (included) for cylinders with diameter Ø4~60mm



small V-type anvil (optional) for cylinders with diameter Ø2~4mm



wireless printer (optional)



desk (optional)

SPECIFICATION

Hardness scale	HRA, HRB, HRC, HRD HRF, HRG (with standard indenters) HRE, HRH, HRK (with optional indenter)
Preliminary test force	98N
Test force	588N, 980N, 1471N
Stage elevation	manual
Load control	manual
Resolution	0.1HR
Output	wireless and USB
Memory	500
Max. workpiece height	170mm
Max. testing width	165mm (from the center of indenter to the wall of main body)
Power supply	built-in rechargeable battery
Dimension	520×160×700mm
Weight	60kg

STANDARD DELIVERY

Main unit	1 pc
Ø60mm flat anvil	1 pc
Ø150mm flat anvil	1 pc
V-type anvil	1 pc
Diamond indenter	1 pc
Ø1.5875mm carbide ball indenter	1 pc
Hardness test block HRB88~95	1 pc
Hardness test block HRC60~65	1 pc
Hardness test block HRC20~30	1 pc
Anti-dust cover	1 pc
Software and USB cable	1 pc
AC/DC adapter	1 pc

OPTIONAL ACCESSORY

Wireless printer	ISH-DS-PRINTER
Ø3.175mm carbide ball indenter	ISH-EHK-INDENTER
Hardness test block HRB88~100	HDT-B-HRB
Hardness test block HRC60~70	HDT-B-HRC3
Hardness test block HRC20~30	HDT-B-HRC1
Small V-type anvil	ISH-SMALLANVIL
Desk	HDT-DESK

MOTORIZED ROCKWELL HARDNESS TESTER (BASIC TYPE) CODE HDT-RA151

■ According to ISO 6508



VIDEO



Ø58mm flat anvil
(included)



Ø150mm flat anvil
(included)



V-type anvil (included)
for cylinders with
diameter Ø4-60mm



level (included)



small V-type anvil
(optional) for
cylinders with
diameter Ø2-4mm



desk (optional)

SPECIFICATION

Hardness scale	HRA, HRB, HRC, HRD, HRF, HRG
Preliminary test force	98N
Test force	588N, 980N, 1471N
Display	analogue
Stage elevation	manual
Load control	automatic (load/dwell/unload)
Load dwell time	1~60 second
Min. reading	0.5HR
Max. workpiece height	170mm
Max. testing width	128mm (from the center of indenter to the wall of main body)
Power supply	220V, 50/60Hz
Dimension	500×225×640mm
Weight	65kg

OPTIONAL ACCESSORY

Hardness test block HRA80~84	HDT-B-HRA
Hardness test block HRB88~100	HDT-B-HRB
Hardness test block HRC20~30	HDT-B-HRC1
Hardness test block HRC35~55	HDT-B-HRC2
Hardness test block HRC60~70	HDT-B-HRC3
Small V-type anvil	HDT-RW160-SV
Desk	HDT-DESK

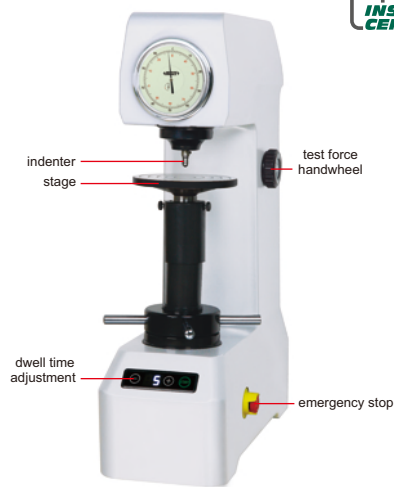

STANDARD DELIVERY

Main unit	1 pc
Ø58mm flat anvil	1 pc
Ø150mm flat anvil	1 pc
V-type anvil	1 pc
Diamond indenter	1 pc
Ø1.5875mm steel ball indenter	1 pc
Level	1 pc
Hardness test block HRA80~88	1 pc
Hardness test block HRB85~95	1 pc
Hardness test block HRC20~30	1 pc
Hardness test block HRC35~55	1 pc
Hardness test block HRC60~70	1 pc
Anti-dust cover	1 pc

MANUAL ROCKWELL HARDNESS TESTER (BASIC TYPE) CODE HDT-RW160

■ According to ISO 6508

POPULAR
MODEL

STANDARD DELIVERY

Main unit	1 pc
Ø58mm flat anvil	1 pc
Ø150mm flat anvil	1 pc
V-type anvil	1 pc
Diamond indenter	1 pc
Ø1.5875mm steel ball indenter	1 pc
Ø1.5875mm steel ball	5 pcs
Level	1 pc
Hardness test block HRA80~88	1 pc
Hardness test block HRB85~95	1 pc
Hardness test block HRC20~30	1 pc
Hardness test block HRC35~55	1 pc
Hardness test block HRC60~70	1 pc
Anti-dust cover	1 pc

OPTIONAL ACCESSORY

Hardness test block HRA80~84	HDT-B-HRA
Hardness test block HRB88~100	HDT-B-HRB
Hardness test block HRC20~30	HDT-B-HRC1
Hardness test block HRC35~55	HDT-B-HRC2
Hardness test block HRC60~70	HDT-B-HRC3
Small V-type anvil	HDT-RW160-SV
Desk	HDT-DESK



Ø58mm flat anvil
(included)



Ø150mm flat anvil
(included)



V-type anvil (included)
for cylinders with
diameter Ø4-60mm



level (included)



small V-type anvil
(optional) for
cylinders with
diameter Ø2-4mm



desk (optional)

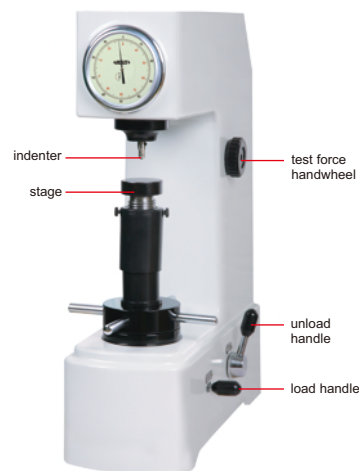

VIDEO

SPECIFICATION

Hardness scale	HRA, HRB, HRC, HRD, HRF, HRG
Preliminary test force	98N (10kg)
Test force	588N (60kg), 980N (100kg), 1471N (150kg)
Display	analogue
Stage elevation	manual
Load control	manual
Min. reading	0.5HR
Max. workpiece height	170mm
Max. workpiece depth	135mm (from the center of indenter to the wall of main body)
Dimension	466×238×630mm
Weight	70kg

**DIGITAL MICRO-VICKERS HARDNESS TESTER (STANDARD TYPE)
CODE HDT-MVH1100**



PRESS INPUT BUTTON TO HAVE DIRECT READING OF HARDNESS

MOTOR DRIVEN TURRET

TOUCH SCREEN

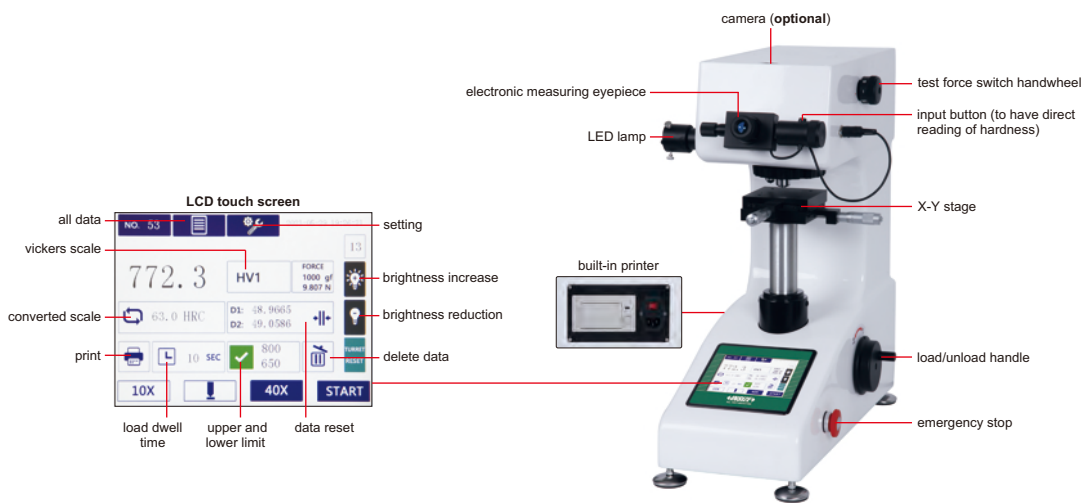

- Touch screen color LCD display
- Data storage and average value calculation
- Automatic switch between the indenter and objective lens
- According to ISO 6507

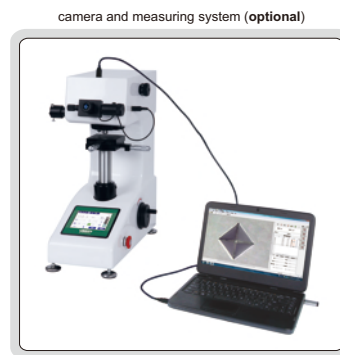
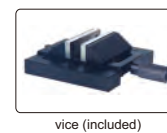

SPECIFICATION

Test force	0.098N (10gf), 0.245N (25gf), 0.49N (50gf), 0.98N (100gf), 1.96N (200gf), 2.94N (300gf), 4.9N (500gf), 9.8N (1kgf)
Vickers scales	HV0.01, HV0.025, HV0.05, HV0.1, HV0.2, HV0.3, HV0.5, HV1
Converted scales	HRA, HRB, HRC, HRD, HRF, HV, HK, HBW, HR15N, HR30N, HR45N, HR15T, HR30T, HR45T
Range	5~3000HV
Length measurement resolution	0.025µm
Objective/indenter switch	motor driven turret
Stage lifting	manual
Load control	automatic (load/dwell/unload)
Load dwell time	1~60 second
Objective	10X, 40X
Eyepiece	10X
Total magnification	10X (for measurement or observation), 400X (for measurement)
Max. workpiece height	90mm
Max. testing width	95mm (from the center of indenter to the wall of main body)
X-Y stage	dimension: 100×100mm, travel range: 25×25mm
Data output	built-in printer
Power supply	220V, 50/60Hz
Dimension	510×290×570mm
Weight	40kg

STANDARD DELIVERY

Main unit	1 pc
10X, 40X objective	1 pc of each
Micro Vickers indenter	1 pc
Hardness test block 400~500HV0.2	1 pc
Hardness test block 700~750HV1	1 pc
Slice holder	1 pc
Vice	1 pc
Cylinder holder	1 pc
Anti-dust cover	1 pc

OPTIONAL ACCESSORY

Hardness test block 400~500HV0.2	HDT-B-HV02C
Hardness test block 700~750HV1	HDT-B-HV1F
Camera	HDT-MVH-CM
Measuring system (manual)	HDT-MVH-SW
Measuring system (automatic)	HDT-MVH-AW

DIGITAL MICRO-VICKERS HARDNESS TESTER (BASIC TYPE) CODE HDT-MVE1300

INSPECTION
CERTIFICATE

MOTOR DRIVEN
TURRET

TOUCH
SCREEN

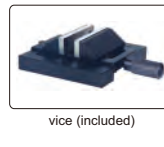
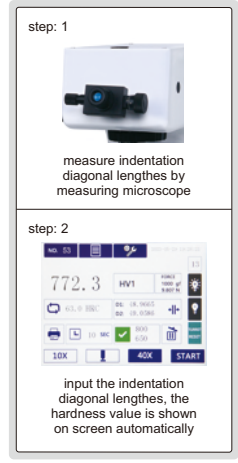
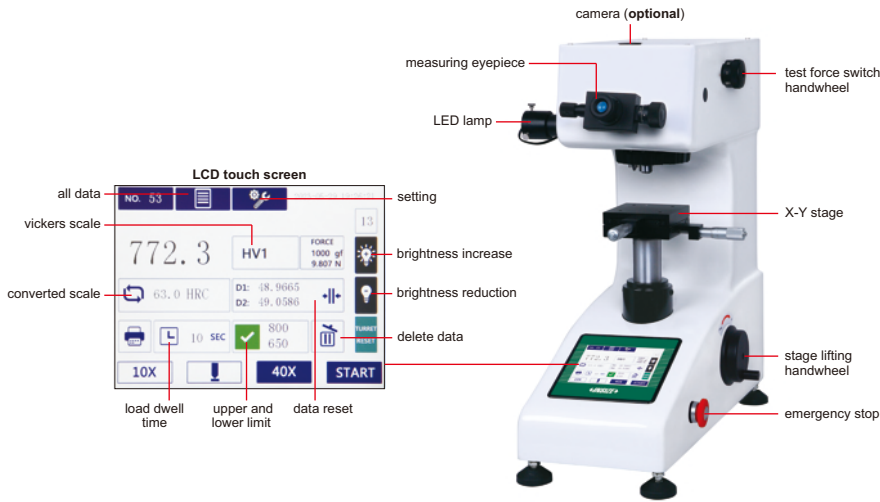

- Touch screen color LCD display
- Data storage and average value calculation
- Automatic switch between the indenter and objective lens
- According to ISO 6507

SPECIFICATION

Test force	0.098N (10gf), 0.245N (25gf), 0.49N (50gf), 0.98N (100gf), 1.96N (200gf), 2.94N (300gf), 4.9N (500gf), 9.8N (1kgf)
Vickers scales	HV0.01, HV0.025, HV0.05, HV0.1, HV0.2, HV0.3, HV0.5, HV1
Converted scales	HRA, HRB, HRC, HRD, HRF, HV, HK, HBW, HR15N, HR30N, HR45N, HR15T, HR30T, HR45T
Range	5~3000HV
Length measurement resolution	0.5µm
Objective/indenter switch	motor driven turret
Stage lifting	manual
Load control	automatic (load/dwell/unload)
Load dwell time	1~60 second
Objective	10X, 40X
Eyepiece	10X
Total magnification	100X (for measurement or observation), 400X (for measurement)
Max. workpiece height	90mm
Max. testing width	95mm (from the center of indenter to the wall of main body)
X-Y stage	dimension: 100×100mm, travel range: 25×25mm
Power supply	220V, 50/60Hz
Dimension	510×290×570mm
Weight	40kg

STANDARD DELIVERY

Main unit	1 pc
10X, 40X objective	1 pc of each
Micro vickers indenter	1 pc
Hardness test block 400~500HV0.2	1 pc
Hardness test block 700~750HV1	1 pc
Slice holder	1 pc
Vice	1 pc
Cylinder holder	1 pc
Anti-dust cover	1 pc

OPTIONAL ACCESSORY

Hardness test block 400~500HV0.2	HDT-B-HV02C
Hardness test block 700~750HV1	HDT-B-HV1F
Camera	HDT-MVH-CM
Measuring system (manual)	HDT-MVH-SW
Measuring system (automatic)	HDT-MVH-AW
Desk	HDT-DESK

DIGITAL VICKERS HARDNESS TESTERS (STANDARD TYPE)

MOTOR DRIVEN
TURRET

PRESS INPUT BUTTON TO HAVE
DIRECT READING OF HARDNESS

TOUCH
SCREEN



- Touch screen color LCD display
- Data storage and average value calculation
- Automatic switch between the indenter and objective lens
- According to ISO 6507

camera and measuring system (optional)

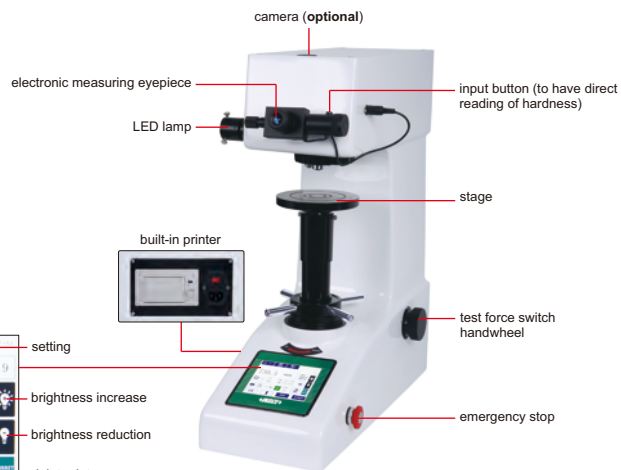
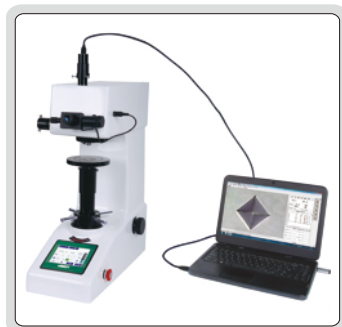

HDT-VH51

SPECIFICATION

Code	HDT-VH05	HDT-VH11	HDT-VH31	HDT-VH51
Test force	0.3kgf, 0.5kgf, 1kgf, 2kgf, 3kgf, 5kgf	0.3kgf, 0.5kgf, 1kgf, 3kgf, 5kgf, 10kgf	1kgf, 3kgf, 5kgf, 10kgf, 20kgf, 30kgf	1kgf, 5kgf, 10kgf, 20kgf, 30kgf, 50kgf
Vickers scales	HV0.3, HV0.5, HV1, HV2, HV3, HV5	HV0.3, HV0.5, HV1, HV3, HV5, HV10	HV1, HV3, HV5, HV10, HV20, HV30	HV1, HV5, HV10, HV20, HV30, HV50
Converted scales	HRA, HRB, HRC, HRD, HRF, HV, HK, HBW, HR15N, HR30N, HR45N, HR15T, HR30T, HR45T			
Range	8~3000HV			
Length measurement resolution	0.125µm			
Objective/indenter switch	motor driven turret			
Stage lifting	manual			
Load control	automatic (load/dwell/unload)			
Load dwell time	1~60 second			
Objective	10X, 20X			
Eyepiece	10X			
Total magnification	100X (for measurement or observation), 200X (for measurement)			
Max. workpiece height	175mm			
Max. testing width	135mm (form the center of indenter to the wall of main body)			
Output	built-in printer			
Power supply	220V, 50/60HZ			
Dimension	580×320×660mm			
Weight	55kg			



Ø58mm flat anvil (included)



V-type anvil (included)



Ø150mm flat anvil (included)



desk (optional)



camera (optional)

STANDARD DELIVERY

Main unit	1 pc
10X, 20X objective	1 pc of each
Vickers indenter	1 pc
Hardness test block	2 pcs
Ø58mm flat anvil	1 pc
Ø150mm flat anvil	1 pc
V-type anvil	1 pc
Anti-dust cover	1 pc

OPTIONAL ACCESSORY

Hardness test block	see details
Desk	HDT-DESK
Vickers hardness tester camera	HDT-MVH-CM1
Measuring system (manual)	HDT-MVH-SW
Measuring system (automatic)	HDT-MVH-AW

vickers hardness measurement system (optional)

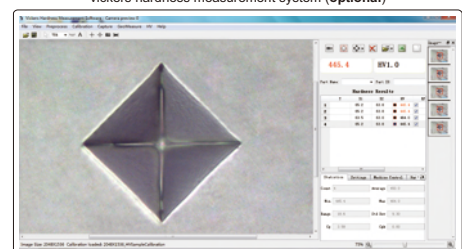

DIGITAL VICKERS HARDNESS TESTERS (BASIC TYPE) CODE HDT-VE56

INSPECTION
CERTIFICATE

MOTOR DRIVEN
TURRET

TOUCH
SCREEN

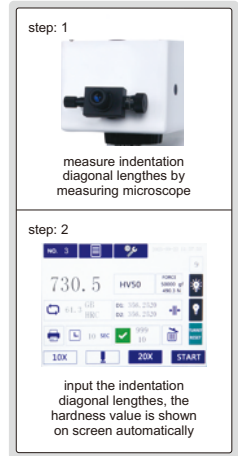
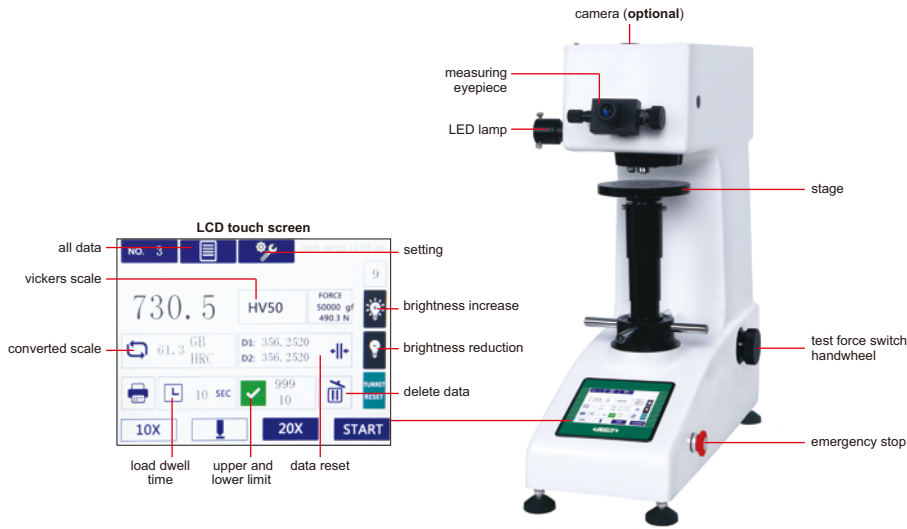

- Touch screen color LCD display
- Data storage and average value calculation
- Automatic switch between the indenter and objective lens
- According to ISO 6507

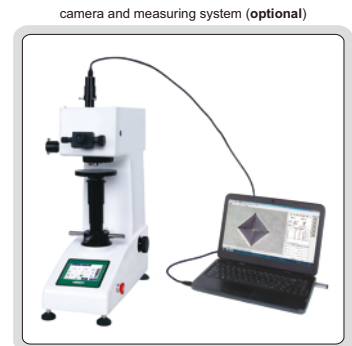
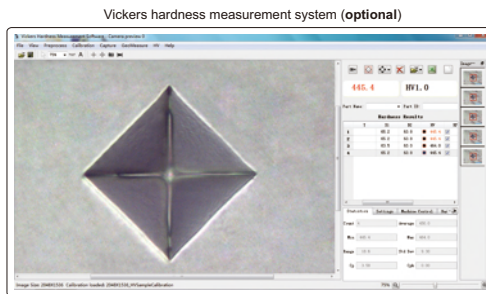

SPECIFICATION

Test force	1kgf, 5kgf, 10kgf, 20kgf, 30kgf, 50kgf
Vickers scales	HV1, HV5, HV10, HV20, HV30, HV50
Converted scales	HRA, HRB, HRC, HRD, HRF, HV, HK, HBW, HR15N, HR30N, HR45N, HR15T, HR30T, HR45T
Range	8~3000HV
Length measurement resolution	0.5µm
Objective/indenter switch	motor driven turret
Stage lifting	manual
Load control	automatic (load/dwell/unload)
Load dwell time	1~60 second
Objective	10X, 20X
Eyepiece	10X
Total magnification	100X (for measurement or observation), 200X (for measurement)
Max. workpiece height	175mm
Max. testing width	135mm (form the center of indenter to the wall of main body)
Power supply	220V, 50/60HZ
Dimension	580×320×660mm
Weight	55kg

STANDARD DELIVERY

Main unit	1 pc
10X, 20X objective	1 pc of each
Vickers indenter	1 pc
Hardness test block 400~500HV10	1 pc
Hardness test block 700~750HV50	1 pc
Ø58mm flat anvil	1 pc
Ø150mm flat anvil	1 pc
V-type anvil	1 pc
Anti-dust cover	1 pc

OPTIONAL ACCESSORY

Hardness test block 400~500HV10	HDT-B-HV10D
Hardness test block 700~750HV50	HDT-B-HV50G
Desk	HDT-DESK
Vickers hardness tester camera	HDT-MVH-CM1
Measuring system (manual)	HDT-MVH-SW
Measuring system (automatic)	HDT-MVH-AW

MOTORIZED DIGITAL BRINELL HARDNESS TESTERS (STANDARD TYPE)



TOUCH SCREEN

FORCE LOADING BY ELECTRIC MOTOR (WITHOUT WEIGHT)

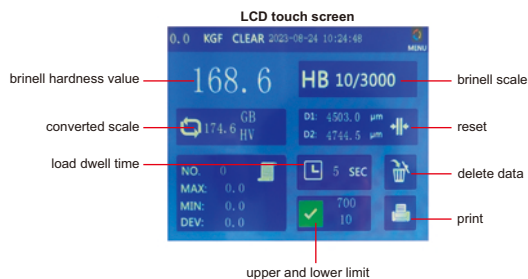

- Touch screen color LCD display
- Measure the indentation with microscope, automatically calculate the hardness value and display it on the screen
- Electric loading test force, without weights
- Casting case, structurally stable and not deformed
- According to ISO 6506

SPECIFICATION

Code	HDT-MB610	HDT-MB710
Turret rotation	manual	automatic
Test force	62.5kgf, 100kgf, 125kgf, 187.5kgf, 250kgf, 500kgf, 750kgf, 1000kgf, 1500kgf, 3000kgf	
Brinell scale	HBW2.5/62.5, HBW2.5/187.5, HBW5/125, HBW5/750, HBW10/100, HBW10/250, HBW10/500, HBW10/1000, HBW10/1500, HBW10/3000	
Range	8~650HBW	
Hardness resolution	0.1HBW	
Stage elevation	manual	
Load control	automatic (load/dwell/unload)	
Load dwell time	0~60 second	
Measuring microscope	magnification	20X
	resolution	0.1μm
Max. workpiece height	200mm	
Max. testing width	135mm (form the center of indenter to the wall of main body)	
Data output	built-in printer, RS232	
Power supply	220V, 50/60Hz	
Dimension	510×210×750mm	
Weight	130kg	

STANDARD DELIVERY

Main unit	1 pc
Ø78mm flat anvil	1 pc
Ø200mm flat anvil	1 pc
V-type anvil	1 pc
Ø2.5mm carbide ball indenter	1 pc
Ø5mm carbide ball indenter	1 pc
Ø10mm carbide ball indenter	1 pc
Hardness test block 100~200HBW2.5/187.5	1 pc
Hardness test block 90~200HBW10/1000	1 pc
Hardness test block 100~200HBW10/3000	1 pc

OPTIONAL ACCESSORY

Hardness test block 100~200HBW2.5/187.5	HDT-B-HB25A1
Hardness test block 90~200HBW10/1000	HDT-B-HB10C1
Hardness test block 100~200HBW10/3000	HDT-B-HB10A1
Desk	HDT-DESK

MOTORIZED DIGITAL BRINELL HARDNESS TESTER (BASIC TYPE) CODE HDT-MBE320

FORCE LOADING BY ELECTRIC MOTOR (WITHOUT WEIGHT)

TOUCH SCREEN

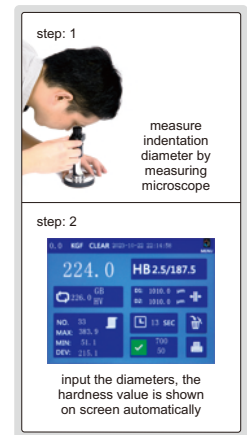
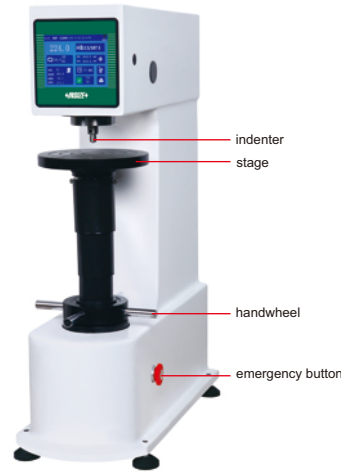
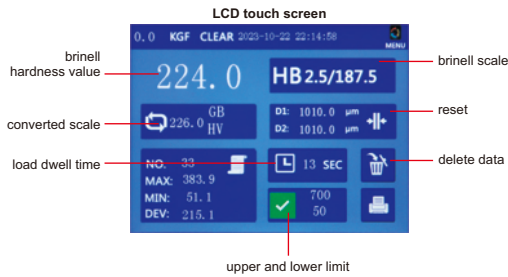

- Touch screen color LCD display SCREEN
- Measure indentation diameter by measuring microscope, then input the diameters, the hardness value is shown on screen automatically
- Electric loading test force, without weights
- Casting case, structurally stable and not deformed
- According to ISO 6506

SPECIFICATION

Test force	62.5kgf, 100kgf, 125kgf, 187.5kgf, 250kgf, 500kgf, 750kgf, 1000kgf, 1500kgf, 3000kgf	
Brinell scale	HBW2.5/62.5, HBW2.5/187.5, HBW5/62.5, HBW5/125, HBW5/250, HBW5/750, HBW10/100, HBW10/250, HBW10/500, HBW10/1000, HBW10/1500, HBW10/3000	
Range	8~650HBW	
Hardness resolution	0.1HBW	
Stage elevation	manual	
Load control	automatic (load/dwell/unload)	
Load dwell time	0~60 second	
Measuring microscope	magnification	20X
	resolution	0.01mm
Max. workpiece height	230mm	
Max. testing width	140mm (form the center of indenter to the wall of main body)	
Power supply	220V, 50/60Hz	
Dimension	510×210×750mm	
Weight	130kg	



STANDARD DELIVERY

Main unit	1 pc
Ø78mm flat anvil	1 pc
Ø200mm flat anvil	1 pc
V-type anvil	1 pc
Ø2.5mm carbide ball indenter	1 pc
Ø5mm carbide ball indenter	1 pc
Ø10mm carbide ball indenter	1 pc
Hardness test block 100~200HBW2.5/187.5	1 pc
Hardness test block 90~200HBW10/1000	1 pc
Hardness test block 100~200HBW10/3000	1 pc
Measuring microscope	1 pc

OPTIONAL ACCESSORY

Hardness test block 100~200HBW2.5/187.5	HDT-B-HB25A1
Hardness test block 90~200HBW10/1000	HDT-B-HB10C1
Hardness test block 100~200HBW10/3000	HDT-B-HB10A1
Desk	HDT-DESK

**BRINELL/ROCKWELL/VICKERS HARDNESS TESTER
CODE ISH-BRV**

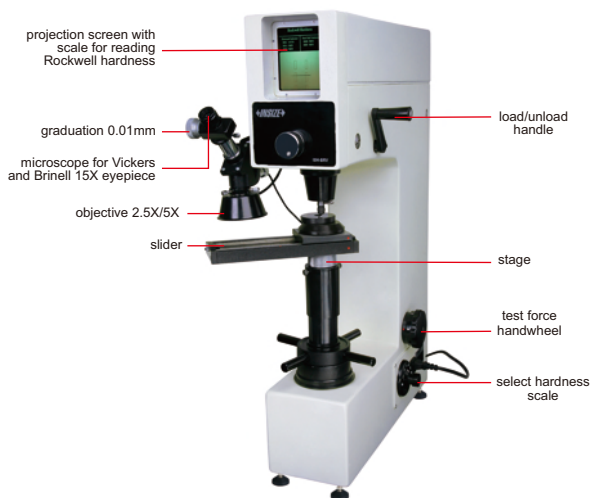

■ According to ISO 6506, ISO 6507, ISO 6508

SPECIFICATION

Rockwell test load	98N preload, 588, 980, 1471N total load
Min. Rockwell reading	0.5HR
Brinell test load	306, 613, 1839N
Vickers test load	294N
Stage elevation	manual
Load control	manual
Magnification of microscope	37.5X/75X
Max. workpiece height	180mm
Max. testing width	200mm (from the center of indenter to the wall of main body)
Power supply	220V, 50/60Hz
Dimension	546×300×767mm
Weight	90kg



STANDARD DELIVERY

Main unit	1 pc
Ø1.5875mm carbide ball indenter	1 pc
Diamond Rockwell indenter	1 pc
Ø5mm Brinell indenter	1 pc
Ø2.5mm Brinell indenter	1 pc
Vickers indenter	1 pc
Ø60mm flat anvil for Rockwell	1 pc
Ø150mm flat anvil for Rockwell	1 pc
V-type anvil for Rockwell	1 pc
Ø60mm flat anvil for Vickers and Brinell	1 pc
V-type anvil for Vickers and Brinell	1 pc
Hardness test block HRB88-95	1 pc
Hardness test block HRC60-65	1 pc
Hardness test block HRC20-30	1 pc
Hardness test block 400-500HV30	1 pc
Hardness test block 180-300HBW2.5/187.5	1 pc
Anti-dust cover	1 pc

OPTIONAL ACCESSORY

Hardness test block HRB88~100	HDT-B-HRB
Hardness test block HRC60~70	HDT-B-HRC3
Hardness test block HRC20~30	HDT-B-HRC1
Hardness test block 400-500HV30	HDT-B-HV30D
Hardness test block 200-3000HBW2.5/187.5	HDT-B-HB25A2
Small V-type anvil for Rockwell	ISH-SMALLANVIL
Desk	HDT-DESK

PORTABLE LEEB HARDNESS TESTERS



BLUETOOTH

DATA OUTPUT

INSPECTION CERTIFICATE

- Can use wired probes or wireless probes
- Dual-coil probe for high accuracy
- Universal testing angle, no need to set impact direction
- Based on Leeb (HLD), converted to Vickers (HV), Brinell (HB), Rockwell (HRC, HRA and HRB), Shore (HS) and tensile strength (σb)
- Dual value display, shows both Leeb and converted hardness
- Large 2.4" LCD display with backlight
- With a magnet on the back, the main unit can be attached on steel surfaces
- According to ASTM A956 and DIN 50156



HDT-CB320
(wired probe is included)



HDT-WL320
(wireless probe is included)

SPECIFICATION

Code	HDT-CB320	HDT-WL320
Probe included	wired probe D	wireless probe D
Optional probes	wired (DC/C/D/D+15/DL/E/G), wireless (DC/C/D/DL/G)	
Resolution	1HLD/1HV/1HB/0.1HRC/0.1HRB/0.1HRA/0.1HS/1MPa	
Accuracy	±6HLD (when HLD=800)	
Output	USB	
Measuring range	HL 170-960/HRC 1.3-74.7/HRB 1.2-139.7/HB 28-1027/ HV 45-1221/HS 4.0-112.1/HRA 1.3-88.5/MPa 118-3315N/mm ²	
Applicable materials	1. steel/cast steel 2. alloy steel 3. stainless steel 4. gray pig iron 5. nodular cast iron 6. cast aluminum 7. brass 8. bronze 9. copper 10. forging steel 11. rolling steel	
Statistics	average/max./min./s.value	
Memory	999 data	
Working environment	-10°C~45°C	
Power supply	2xAA battery	
Dimension	145×68×28mm	
Weight	158g	

connect to bluetooth printer (optional)



connect to PC, upload the data to PC, print and send to Excel (software is included)



STANDARD DELIVERY

Code	HDT-CB320	HDT-WL320
Main unit	1 pc	1 pc
Wired probe D	1 pc	—
Wireless probe D	—	1 pc
Hardness test block D	1 pc	1 pc
Small support ring	1 pc	1 pc
Cleaning brush	1 pc	1 pc

OPTIONAL ACCESSORY

Wired probe	DC	HDT-CB320-DC
	C	HDT-CB320-C
	D	HDT-CB320-D
	D+15	HDT-CB320-D15
	DL	HDT-CB320-DL
	E	HDT-CB320-E
	G	HDT-CB320-G
Wireless probe	DC	HDT-WL320-DCW
	C	HDT-WL320-CW
	D	HDT-WL320-DW
	DL	HDT-WL320-DLW
	G	HDT-WL320-GW
Hardness test block D **	HDT-B-HLD3	
Hardness test block G *	HDT-B-HLG2	
Printer	ISH-LP200-PRINTER	
Support rings	see details	



small support ring (included)



hardness test block D (included)

wireless probes (optional)

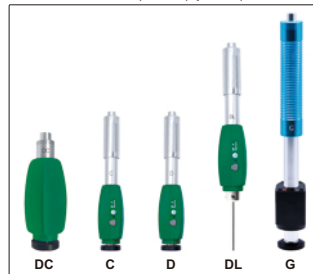

wired probes (optional)

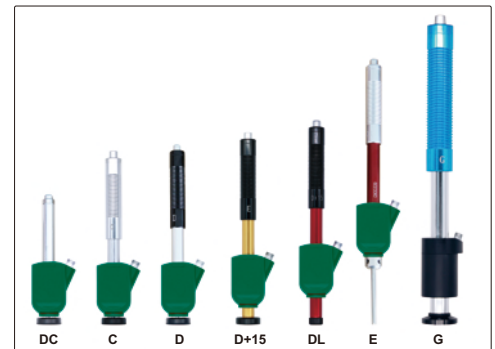

- * Hardness test block G (HDT-B-HLG2) is for probe G (HDT-CB320-G or HDT-WL320-GW)
- ** Hardness test block D (HDT-B-HLD3) is for all other probes

APPLICABLE WORKPIECE

Probes	DC	C	D	D+15	DL	E	G
Application	inner wall of small space	small or thin workpiece, coating layer	general use	deep groove	narrow slot or small hole	very hard material	casting or forging workpiece
Maximum roughness of workpiece (Ra)	2μm	0.4μm	2μm	2μm	2μm	2μm	7μm
Minimum weight of workpiece	direct measurement	5kg	1.5kg	5kg	5kg	5kg	15kg
	on solid support	2.5kg	0.5kg	2kg	2kg	2.5kg	5kg
	coupled on plate	0.05-2kg	0.02kg	0.05-2kg	0.1kg	0.1kg	0.5kg
Minimum thickness of workpiece	3mm	1mm	3mm	3mm	3mm	3mm	10mm

PORTABLE LEEB HARDNESS TESTER (BASIC TYPE) CODE HDT-LP200

POPULAR
MODEL

INSPECTION
CERTIFICATE



- Can change probes
- Dual-coil probe for high accuracy
- Universal testing angle, no need to set impact direction
- Based on Leeb (HLD), converted to Vickers (HV), Brinell (HB), Rockwell (HRC, HRB), Shore (HSD) and tensile strength (σ_b)
- Dual value display, shows both Leeb and converted hardness
- Large LCD display with backlight
- Can choose large font display and statistics display
- Automatically calculate maximum, minimum and average value
- Save 300 data
- Operation temperature: -10°C ~ 45°C
- According to ASTM A956, GB/T 17394

SPECIFICATION

Resolution	1HLD/1HV/1HB/0.1HRC/0.1HRB/0.1HSD/1 σ_b
Accuracy	$\pm 6\text{HLD}$ (when HLD=800)
Measuring range	HL 170-960/HRC 17-70/HRB 13-109/HB 20-655/ HV 80-940/HSD 32-99.5/ $\sigma_b(\text{rm})$ 255-2639N/mm ²
Power supply	2xAA battery
Dimension	135×77×32mm
Weight	240g

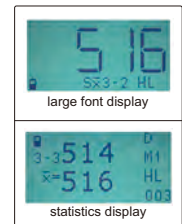

STANDARD DELIVERY

Main unit	1 pc
Hardness test block D	1 pc
Small support ring	1 pc
Cleaning brush	1 pc
Impact device D	1 pc

OPTIONAL ACCESSORY

Impact device DC	HDT-LP200-DC
Impact device C	HDT-LP200-C
Impact device D+15	HDT-LP200-D15
Impact device DL	HDT-LP200-DL
Impact device G	HDT-LP200-G
Hardness test block D **	HDT-B-HLD3
Hardness test block G *	HDT-B-HLG2
Support rings	see details

*Hardness test block G (HDT-B-HLG2) is for impact device G (HDT-LP200-G)

**Hardness test block D (HDT-B-HLD3) is for all other impact devices

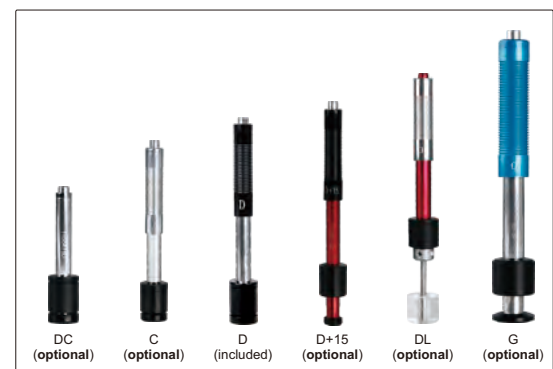

APPLICABLE WORKPIECE

Impact device	DC	C	D	D+15	DL	G
Application	inner wall of small space	small or thin workpiece, coating layer	general use	deep groove	narrow slot or small hole	casting or forging workpiece
Maximum roughness of workpiece (Ra)	2 μm	0.4 μm	2 μm	2 μm	2 μm	7 μm
Minimum weight of workpiece	direct measurement	5kg	1.5kg	5kg	5kg	15kg
	on solid support	2kg	0.5kg	2kg	2kg	5kg
	coupled on plate	0.05kg	0.02kg	0.05kg	0.1kg	0.05kg
Minimum thickness of workpiece	3mm	1mm	3mm	3mm	3mm	10mm

PORTABLE LEEB HARDNESS TESTER WITH PROBE CODE HDT-WP201



- Bluetooth digital probe
- Universal testing angle, no need to set impact direction
- Based on Leeb (HLD), converted to Vickers (HV), Brinell (HB), Rockwell (HRC, HRB), Shore (HSD) and tensile strength (σb)
- Dual value display, shows both Leeb and converted hardness
- Large LCD display with backlight
- Can choose large font display and statistics display
- Automatically calculate maximum, minimum and average value
- Save 300 data
- Operation temperature: -10°C~45°C
- According to ASTM A956, DIN 50156 GB/T 17394



SPECIFICATION

Resolution	1HLD/1HV/1HB/0.1HRC/0.1HRB/ 0.1HSD/1σb
Accuracy	±6HLD (when HLD=800)
Measuring range	HL 170-960/HRC 17-69/HRB 13-101.7/ HB 20-655/HV 80-940/HSD 32-99.5/ σb (rm) 255-2180N/mm ²
Power supply	2xAA battery
Dimension	135×77×32mm
Weight	240g



small support ring
(included)



hardness test block D
(included)



bluetooth printer
(optional)

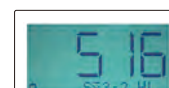

large font display

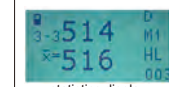

statistics display

STANDARD DELIVERY

Main unit	1 pc
Hardness test block D	1 pc
Small support ring	1 pc
Cleaning brush	1 pc
Impact device D	1 pc

OPTIONAL ACCESSORY

Impact device DC	HDT-WL320-DCW
Impact device C	HDT-WL320-CW
Impact device DL	HDT-WL320-DLW
Impact device G	HDT-WL320-GW
Hardness test block D	HDT-B-HLD3
Bluetooth printer	HDT-LP200-PRINTER
Support rings	see details

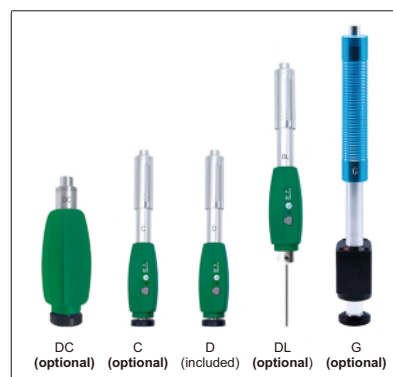

DC (optional) C (optional) D (included) DL (optional) G (optional)

APPLICABLE WORKPIECE

Impact device	DC	C	D	DL	G
Application	inner wall of small space	small or thin workpiece, coating layer	general use	narrow slot or small hole	casting or forging workpiece
Maximum roughness of workpiece (Ra)	2μm	0.4μm	2μm	2μm	7μm
Minimum weight of workpiece	direct measurement	5kg	1.5kg	5kg	15kg
	on solid support	2kg	0.5kg	2kg	5kg
	coupled on plate	0.05kg	0.02kg	0.05kg	0.05kg
Minimum thickness of workpiece	3mm	1mm	3mm	3mm	10mm

PEN-TYPE LEEB HARDNESS TESTER (ADVANCED TYPE) CODE HDT-L410

INSPECTION
CERTIFICATE

DATA
OUTPUT

HIGH
ACCURACY

DL PROBE IS
OPTIONAL



- Metal housing
- HD TFT 320×320 display
- Impact device D
- Based on Leeb (HLD), converted to Vickers (HV), Brinell (HB), Rockwell (HRC, HRA and HRB), Shore (HS) and tensile strength (SGM)
- Four display modes
- Automatic direction correction
- Tolerance testing
- Automatic power off, automatic calculation of statistics
- Dual value display, shows both Leeb and other conversion values
- 31 files can be saved, each containing 100 measurement data
- Connected to PC software via USB or Bluetooth 2.0
- Connected with printer via Bluetooth
- Operation temperature: -20°C~70°C
- According to ASTM A956, DIN 50156, GB/T 17394



DL probe can be installed (optional)



software flash disk (included)



small support ring (included)



hardness test block D (included)



wireless printer (optional)

histogram display

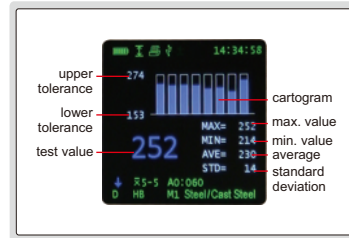

dynamic ring display

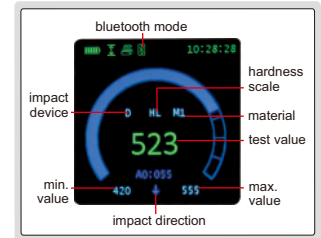

can choose large font display

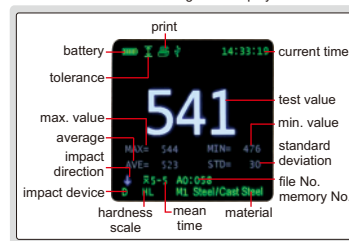

statistic display

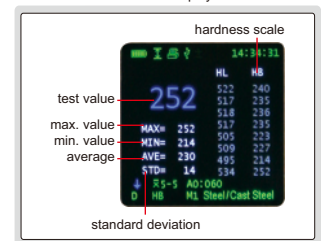

software (included), upload the memory to PC, print and send to EXCEL

upload the memory to PC software via USB cable or Bluetooth

send the stored data to EXCEL

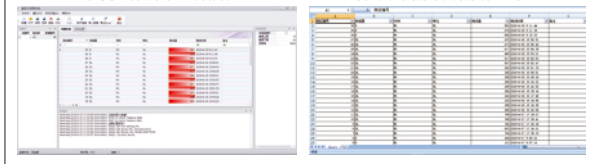

SPECIFICATION

Resolution	1HLD, 1HV, 1HB, 0.1HRC, 0.1HRB, 0.1HRA, 0.1HS, 1SGM	
Accuracy	±4HLD (when HLD=800)	
Output	USB and bluetooth	
Applicable workpiece	minimum weight	5kg (direct measurement)
		2kg (on solid support)
		0.05kg (coupled on plate)
	minimum thickness: 5mm	
minimum radius of curved surface: 30mm		
maximum roughness (Ra): 2µm		
Power supply	built-in 3.7V rechargeable battery	
Dimension	148×44×22mm	
Weight	115g	

STANDARD DELIVERY

Main unit	1 pc
Hardness test block D	1 pc
Small support ring	1 pc
Cleaning brush	1 pc
AC/DC adapter	1 pc
Software flash disk and USB cable	1 pc

OPTIONAL ACCESSORY

Printer	HDT-L410-PRINTER
Support rings	ISH-PH-SP9
Hardness test block D	HDT-B-HLD3
DL probe	HDT-L410-DL

PEN-TYPE LEEB HARDNESS TESTER (BASIC TYPE) CODE HDT-L411

INSPECTION
CERTIFICATE

DATA
OUTPUT



hardness test block D (included)



small support ring (included)



software flash disk (included)

- Impact device D
- Universal testing angle, no need to set impact direction
- Dual-coil probe, high accuracy
- Based on Leeb (HLD), converted to Vickers (HV), Brinell (HB), Rockwell (HRC, HRA and HRB), Shore (HS) and tensile strength (SGM)
- Dual value display, shows both Leeb and converted hardness
- High contrast digital LCD display
- Can choose large font display
- Automatically calculate maximum, minimum, average value
- Connected to PC via USB
- Save 999 data
- Operation temperature: -20°C~45°C
- According to ASTM A956, DIN 50156, GB/T 17394



can choose large font display

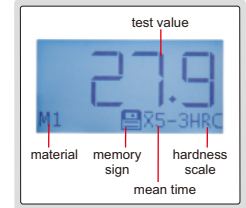

software (included), upload the memory to PC, print and send to EXCEL

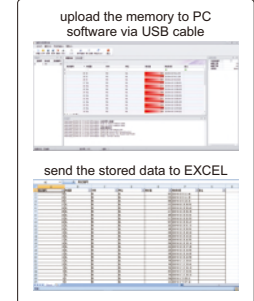

SPECIFICATION

Resolution	1HLD, 1HV, 1HB, 0.1HRC, 0.1HRB, 0.1HRA, 0.1HS, 1SGM	
Accuracy	±6HLD (when HLD=800)	
Output	USB	
Measuring range	HL100-960, HRC1-74.7, HRB1.2-140, HB28-1027, HV45-1230, HS4-112, HRA7-88.5, SGM (rm) 118-3315N/mm ²	
Applicable workpiece	minimum weight	5kg (direct measurement)
		2kg (on solid support)
		0.05kg (coupled on plate)
	minimum thickness: 5mm	
minimum radius of curved surface: 30mm		
maximum roughness (Ra): 2µm		
Power supply	1xAAA battery	
Dimension	148×45×21mm	
Weight	105g	



VIDEO

STANDARD DELIVERY

Main unit	1 pc
Hardness test block D	1 pc
Cleaning brush	1 pc
AAA battery	1 pc
Small support ring	1 pc
Software flash disk and USB cable	1 pc

OPTIONAL ACCESSORY

Support rings	see details
Hardness test block D	HDT-B-HLD3

PORTABLE ROCKWELL HARDNESS TESTER CODE ISHR-P151

- According to ISO 6508, ASTM E18



anvil extension for thin workpieces (included)



flat anvil (included)



V-type anvil (included)



VIDEO

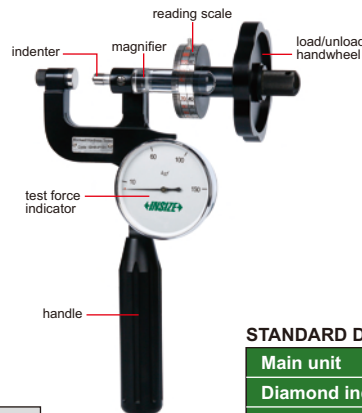

SPECIFICATION

Hardness scale	HRA, HRB, HRC, HRD, HRF, HRG
Preliminary test force	10kg
Test force	60kg, 100kg, 150kg
Load control	manual
Min. reading	1HR
Max. workpiece thickness	25mm
Max. testing width	25mm (from the center of indenter to the main body)
Dimension	240×70×160mm
Weight (with base)	2.5kg

STANDARD DELIVERY

Main unit	1 pc
Diamond indenter	1 pc
Ø1.5875mm carbide ball indenter	2 pcs
Hardness test block HRB88-95	1 pc
Hardness test block HRC60-65	1 pc
Hardness test block HRC20-30	1 pc
Flat anvil	1 pc
V-type anvil	1 pc
Base	1 pc
Anvil extension	1 pc
Magnifier	2 pcs

HYDRAULIC BRINELL HARDNESS TESTER CODE ISHB-H131



- According to ISO 6506, ASTM E10

SPECIFICATION

Measuring range	16~650HBW
Test force	3000kg
Indenter	Ø10mm carbide ball
Measuring microscope	20X, graduation 0.01mm
Max. workpiece height	350mm
Max. testing width	90mm (from the center of indenter to the column)
Dimension	270×225×570mm
Weight	13.8kg

STANDARD DELIVERY

Main unit	1 pc
Flat anvil	1 pc
V-type anvil	1 pc
Spherical anvil	1 pc
Ø10mm carbide ball	2 pcs
Brinell test block	2 pcs
Measuring microscope	1 pc

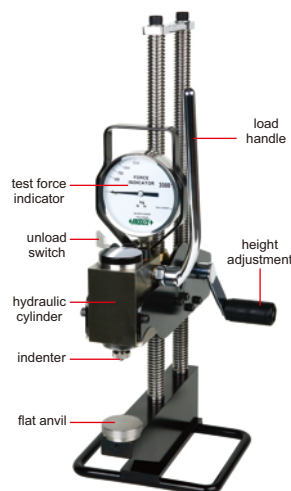

V-type anvil (included)



spherical anvil (included)



measuring microscope (included)

ALUMINUM HARDNESS TESTERS (BASIC TYPE)



- To measure the hardness of soft metal such as aluminum alloy, copper, brass, soft steel, etc.
- According to ASTM B647-10 (2016)

STANDARD DELIVERY

Main unit	1 pc
Spare indenter	1 pc
Hardness test block	1 pc
Wrench	1 pc



ISHW-H10

SPECIFICATION

Code	ISHW-H10	ISHW-H11	ISHW-H12	ISHW-H13	ISHW-H14	ISHW-H15
Application	for aluminum alloy general use	for aluminum alloy thick workpiece	for aluminum alloy small tube	for hard aluminum alloy and hard brass	for soft brass and copper	for soft steel and cold-rolled steel
Thickness requirement of flat workpiece	0.6~6mm	0.6~13mm	0.6~8mm	0.6~6mm	0.6~6mm	0.6~6mm
Internal diameter requirement of tube workpiece	>Ø10mm	>Ø10mm	>Ø6mm	>Ø10mm	>Ø10mm	>Ø10mm
Wall thickness requirement of tube workpiece	0.6~6mm	6~13mm (internal diameter Ø10~23.3mm) 6~13mm (internal diameter >Ø23.3mm)	0.6~8mm	0.6~6mm	0.6~6mm	0.6~6mm
Hardness range	0~20HW					
Min. reading	1HW					
Accuracy	±0.5HW (at 5~17HW)					
Dimension	205×30×95mm					
Weight	500g					

ALUMINUM HARDNESS TESTER

- To measure the hardness of soft metal such as aluminum alloy, copper, brass, soft steel, etc.
- According to ASTM B647-84 (2000)



ISHW-L20

SPECIFICATION

Code	ISHW-L20
Application	for aluminum alloy general use
Thickness requirement of flat workpiece	0.6~6mm
Internal diameter requirement of tube workpiece	>Ø10mm
Wall thickness requirement of tube workpiece	0.6~6mm
Hardness range	0~20HW
Min. reading	1HW
Accuracy	±0.5HW (at 5~17HW)
Dimension	205x30x85mm
Weight	500g

STANDARD DELIVERY

Main unit	1 pc
Spare indenter	1 pc
Hardness test block	1 pc
Wrench	1 pc

ALUMINUM HARDNESS TESTER CODE ISHB-B300



- To measure the hardness of workpieces made of pure aluminum, aluminum alloy, fiber reinforced plastic, hard plastic, etc.
- According to ASTM B648-00, ASTM D2853-07

STANDARD DELIVERY

Main unit	1 pc
Spare indenter	2 pcs
Hardness test block	2 pcs
Wrench	1 pc

SPECIFICATION

Hardness range	0~100HBa (equal to 25~150HBW)
Min. reading	1HBa
Accuracy	±2HBa (at 42~52HBa) ±1HBa (at 84~88HBa)
Min. workpiece thickness	0.8mm
Dimension	142×65×90mm
Weight	500g

TEST STAND FOR DIGITAL SHORE DUROMETERS CODE ISH-DS-STANDA

- For digital shore durometers (code ISH-DSA, ISH-DSD and ISH-DOO)
- Perform repeatable hardness measurement due to fewer possibilities of human error or measurement variations
- Special structure for stable loading
- Weight block A (included) is for ISH-DSA, weight block D (optional) is for ISH-DSD, remove weight block for ISH-DOO

SPECIFICATION

Stage diameter	Ø115mm
Max. workpiece height	45mm
Max. testing width	63mm (from test point to the column)
Dimension	Ø195×370mm
Weight	5.61kg



weight block D (optional) for ISH-DSD

STANDARD DELIVERY

Test stand	1 pc
Weight block A (for ISH-DSA)	1 pc

OPTIONAL ACCESSORY

Weight block D (for ISH-DSD)	ISH-DS-W4
------------------------------	-----------

DIGITAL SHORE DUROMETERS

- According to ISO868, ISO7619, ASTM D 2240
- Average and peak (max.) mode
- Dwell time is adjustable
- Tolerance testing
- 500 memories
- Wireless connection to printer
- Handhold use or work with test stand (code **ISH-DS-STANDA**)
- Automatic power off



SPECIFICATION

Code	ISH-DSA	ISH-DSD	ISH-DSOO
Unit	Shore A	Shore D	Shore OO
Test material	soft plastic, soft rubber, etc.	hard plastic, hard rubber, etc.	very soft plastic, rubber, sponge, textile, etc.
Measuring range	0~100HA*	0~100HD*	0~100HOO
Resolution	0.1HA	0.1HD	0.1HOO
Accuracy	±1HA	±1HD	±1HOO
Indenter protrusion	2.5mm		
Output	wireless and USB		
Power supply	built-in rechargeable battery		
Dimension	153×50×29mm		
Weight	170g		

* Use **ISH-DSD** when measuring result is higher than 90HA
Use **ISH-DSA** when measuring result is lower than 20HD

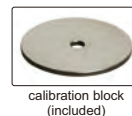

STANDARD DELIVERY

Main unit	1 pc
Calibration block	1 pc
Software and USB cable	1 pc
AC/DC adapter	1 pc



OPTIONAL ACCESSORY

Printer	ISH-DS-PRINTER
Test stand	ISH-DS-STANDA



SHORE DUROMETERS

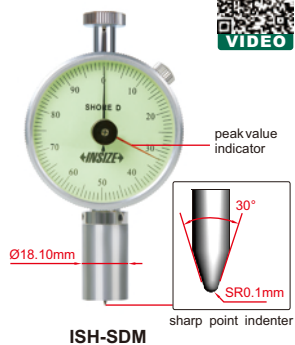
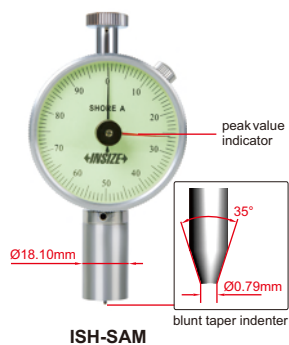

- According to ISO868, ISO7619, ASTM D 2240
- With peak value indicator
- Optional accessory: test stand **ISH-STAC** and **ISH-STD**

SPECIFICATION

Code	ISH-SAM	ISH-SDM
Scale	Shore A	Shore D
Application	natural rubber, soft elastomer, etc.	hard rubber, plastic, hard elastomer, etc.
Measuring range*	10~90HA	20~90HD
Graduation	1HA	1HD
Indenter protrusion	2.5mm	
Dimension	115x60x25mm	
Weight	160g	

* Use **ISH-SDM** when measuring result is higher than 90HA
Use **ISH-SAM** when measuring result is lower than 20HD

OPTIONAL ACCESSORY

Calibration block	ISH-DS-BLOCK
-------------------	--------------

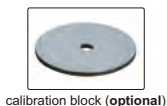

TEST STANDS FOR SHORE DUROMETERS



- For shore durometers (code **ISH-SAM** and **ISH-SDM**)
- Perform repeatable hardness measurement due to fewer possibilities of human error or measurement variations



SPECIFICATION

Code	ISH-STAC	ISH-STD
Applicable durometer	ISH-SAM	ISH-SDM
Stage diameter	Ø100mm	Ø100mm
Max. workpiece height	75mm	75mm
Max. testing width	65mm (from test point to the column)	65mm (from test point to the column)
Weight block	1kg	5kg

HARDNESS TEST BLOCKS



■ Supplied with manufacturer inspection certificate

Micro-Vickers hardness test blocks

Code	Type	Hardness
HDT-B-HV005A	HV0.05	200-300
HDT-B-HV005B	HV0.05	300-400
HDT-B-HV005C	HV0.05	400-500
HDT-B-HV005D	HV0.05	500-600
HDT-B-HV005E	HV0.05	600-700
HDT-B-HV005F	HV0.05	700-750
HDT-B-HV01A	HV0.1	200-300
HDT-B-HV01B	HV0.1	300-400
HDT-B-HV01C	HV0.1	400-500
HDT-B-HV01D	HV0.1	500-600
HDT-B-HV01E	HV0.1	600-700
HDT-B-HV01F	HV0.1	700-750
HDT-B-HV02A	HV0.2	200-300
HDT-B-HV02B	HV0.2	300-400
HDT-B-HV02C	HV0.2	400-500
HDT-B-HV02D	HV0.2	500-600
HDT-B-HV02E	HV0.2	600-700
HDT-B-HV02F	HV0.2	700-750
HDT-B-HV03A	HV0.3	200-300
HDT-B-HV03B	HV0.3	300-400
HDT-B-HV03C	HV0.3	400-500
HDT-B-HV03D	HV0.3	500-600
HDT-B-HV03E	HV0.3	600-700
HDT-B-HV03F	HV0.3	700-750
HDT-B-HV05A	HV0.5	200-300
HDT-B-HV05B	HV0.5	300-400
HDT-B-HV05C	HV0.5	400-500
HDT-B-HV05D	HV0.5	500-600
HDT-B-HV05E	HV0.5	600-700
HDT-B-HV05F	HV0.5	700-750
HDT-B-HV1A	HV1	200-300
HDT-B-HV1B	HV1	300-400
HDT-B-HV1C	HV1	400-500
HDT-B-HV1D	HV1	500-600
HDT-B-HV1E	HV1	600-700
HDT-B-HV1F	HV1	700-750

Vickers hardness test blocks

Code	Type	Hardness
HDT-B-HV5A	HV5	175-200
HDT-B-HV5B	HV5	200-300
HDT-B-HV5C	HV5	300-400
HDT-B-HV5D	HV5	400-500
HDT-B-HV5E	HV5	500-600
HDT-B-HV5F	HV5	600-700
HDT-B-HV5G	HV5	700-750
HDT-B-HV10A	HV10	175-200
HDT-B-HV10B	HV10	200-300
HDT-B-HV10C	HV10	300-400
HDT-B-HV10D	HV10	400-500
HDT-B-HV10E	HV10	500-600
HDT-B-HV10F	HV10	600-700
HDT-B-HV10G	HV10	700-750
HDT-B-HV30A	HV30	175-200
HDT-B-HV30B	HV30	200-300
HDT-B-HV30C	HV30	300-400
HDT-B-HV30D	HV30	400-500
HDT-B-HV30E	HV30	500-600
HDT-B-HV30F	HV30	600-700
HDT-B-HV30G	HV30	700-750
HDT-B-HV50A	HV50	175-200
HDT-B-HV50B	HV50	200-300
HDT-B-HV50C	HV50	300-400
HDT-B-HV50D	HV50	400-500
HDT-B-HV50E	HV50	500-600
HDT-B-HV50F	HV50	600-700
HDT-B-HV50G	HV50	700-750
HDT-B-HV100A	HV100	175-200
HDT-B-HV100B	HV100	200-300
HDT-B-HV100C	HV100	300-400
HDT-B-HV100D	HV100	400-500
HDT-B-HV100E	HV100	500-600
HDT-B-HV100F	HV100	600-700
HDT-B-HV100G	HV100	700-750

Rockwell hardness test blocks

Code	Type	Hardness
HDT-B-HRA	HRA	80-84
HDT-B-HRB	HRB	88-100
HDT-B-HRC1	HRC	20-30
HDT-B-HRC2	HRC	35-55
HDT-B-HRC3	HRC	60-70
HDT-B-HRD1	HRD	40-47
HDT-B-HRD2	HRD	55-63
HDT-B-HRD3	HRD	70-75
HDT-B-HRE	HRE	107-114
HDT-B-HRF	HRF	105-114
HDT-B-HRG1	HRG	57-82
HDT-B-HRG2	HRG	80-94

Leeb hardness test blocks

Code	Type	Hardness
HDT-B-HLD1	HLD	490-570
HDT-B-HLD2	HLD	590-670
HDT-B-HLD3	HLD	750-830
HDT-B-HLG1	HLG	460-540
HDT-B-HLG2	HLG	550-630

Rockwell superficial hardness test blocks

Code	Type	Hardness
HDT-B-HR15N1	HR15N	70-77
HDT-B-HR15N2	HR15N	78-88
HDT-B-HR15N3	HR15N	89-91
HDT-B-HR30N1	HR30N	42-54
HDT-B-HR30N2	HR30N	55-73
HDT-B-HR30N3	HR30N	74-80
HDT-B-HR45N1	HR45N	20-31
HDT-B-HR45N2	HR45N	32-61
HDT-B-HR45N3	HR45N	63-70
HDT-B-HR15T	HR15T	88-93
HDT-B-HR30T	HR30T	73-82
HDT-B-HR45T	HR45T	58-72

Brinell hardness test blocks

Code	Type	Hardness
HDT-B-HB10A1	HBW10/3000	100-200
HDT-B-HB10A2	HBW10/3000	200-300
HDT-B-HB10A3	HBW10/3000	300-400
HDT-B-HB10A4	HBW10/3000	400-500
HDT-B-HB10A5	HBW10/3000	500-600
HDT-B-HB10A6	HBW10/3000	600-650
HDT-B-HB10B1	HBW10/1500	100-200
HDT-B-HB10B2	HBW10/1500	200-300
HDT-B-HB10B3	HBW10/1500	300-400
HDT-B-HB10B4	HBW10/1500	400-500
HDT-B-HB10B5	HBW10/1500	500-600
HDT-B-HB10B6	HBW10/1500	600-650
HDT-B-HB10C1	HBW10/1000	90-200
HDT-B-HB10C2	HBW10/1000	200-300
HDT-B-HB10C3	HBW10/1000	300-400
HDT-B-HB10C4	HBW10/1000	400-450
HDT-B-HB10D1	HBW10/500	90-200
HDT-B-HB10D2	HBW10/500	200-300
HDT-B-HB10D3	HBW10/500	300-400
HDT-B-HB10D4	HBW10/500	400-450
HDT-B-HB25A1	HBW2.5/187.5	100-200
HDT-B-HB25A2	HBW2.5/187.5	200-300
HDT-B-HB25A3	HBW2.5/187.5	300-400
HDT-B-HB25A4	HBW2.5/187.5	400-500
HDT-B-HB25A5	HBW2.5/187.5	500-600
HDT-B-HB25A6	HBW2.5/187.5	600-650
HDT-B-HB25B1	HBW2.5/62.5	90-200
HDT-B-HB25B2	HBW2.5/62.5	200-300
HDT-B-HB25B3	HBW2.5/62.5	300-400
HDT-B-HB25B4	HBW2.5/62.5	400-450
HDT-B-HB5A1	HBW5/750	100-200
HDT-B-HB5A2	HBW5/750	200-300
HDT-B-HB5A3	HBW5/750	300-400
HDT-B-HB5A4	HBW5/750	400-500
HDT-B-HB5A5	HBW5/750	500-600
HDT-B-HB5A6	HBW5/750	600-650
HDT-B-HB5B1	HBW5/250	90-200
HDT-B-HB5B2	HBW5/250	200-300
HDT-B-HB5B3	HBW5/250	300-400
HDT-B-HB5B4	HBW5/250	400-450

Shore hardness test blocks

Code	Type	Hardness *
HDT-B-SA	SA	6 pcs/set (30, 40, 50, 60, 70, 80)
HDT-B-SD	SD	3 pcs/set (15, 30, 90)

*The actual value may be slightly different when delivered



Cutting Machines
Page 273



Mounting Presses
Page 273



Grinders And Polishers
Page 274

CUTTING MACHINE (BASIC TYPE) CODE MLP-CM86

- For metal and non-metal materials
- Cooling device avoids overheating and destroying sample structure



VIDEO

SPECIFICATION

Maximum cutting diameter	Ø80mm
Cutting blade	Ø250×2×Ø32mm
Rotation speed	2800r/min
Power	3kW
Power supply	AC 380V, 50Hz
Dimension	690×790×670mm

STANDARD DELIVERY

Main unit	1 pc
Cutting blade	2 pcs
Coolant	1 barrel (4L)
Water tank	1 pc

OPTIONAL ACCESSORY

Coolant (4L, 1:20 diluted with water)	MLP-OL3
Cutting blade (Ø250×2×Ø32mm, 50 pcs/box)	MLP-60Y2*
	MLP-50Z2
Cutting blade chuck (for Ø32mm cutting blade)	MLP-CM86-CHUCK

* Special cutting blade for high hardness



coolant (included)

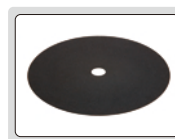

cutting blade MLP-50Z2 (included)

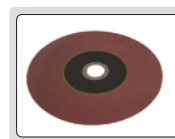

cutting blade MLP-60Y2 (optional)

MOUNTING PRESS (BASIC TYPE) CODE MLP-MP62

- Suitable for tiny, difficult to handle or irregular metallographic and petrographic samples
- The sample preparation program has three modes: bakelite powder, electric jade powder and user-defined
- The sample preparation program controls the sample preparation time and realizes unattended sample preparation

SPECIFICATION

Mounting diameter	Ø30mm (customizable Ø22mm, Ø45mm)
Heating range	room temperature~200°C
Timing range	0~30min
Power	≤800W
Power supply	AC220V, 50Hz
Dimension	440×253×310mm
Weight	32kg

STANDARD DELIVERY

Main unit	1 pc
Hot mounting resin	1 bottle (60g)
Funnel	1 pc



VIDEO



hot mounting resin (included)

OPTIONAL ACCESSORY

Hot mounting resin (black, 4kg)

MLP-DR3

GRINDER AND POLISHER (BASIC TYPE) CODE MLP-GP314



silicon carbide paper
(included)

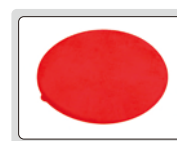

polishing cloth (included)



anti-stick disc (optional)

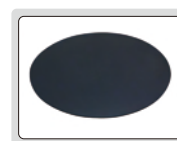

magnetic pad (optional)

- Double wheels, rotation direction can be selected
- Smooth rotation, low noise
- Water cooling device, prevent samples from overheating and destroying structure
- Replaceable silicon carbide paper and polishing cloth for grinding and polishing process

SPECIFICATION

Wheel diameter	Ø203mm
Wheel rotation speed	0~1400r/min (stepless adjustable)
Wheel rotation direction	clockwise or counterclockwise
Power supply	AC 200V, 50HZ
Input power	0.75kW
Dimension	755×700×310mm
Weight	50kg

STANDARD DELIVERY

Main unit	1 pc
Silicon carbide paper	5 pcs each (240, 400, 800, 1200), 20 pcs in total
Polishing cloth	4 pcs
Polishing agent	1 pc (W2.5, 500ml)

OPTIONAL ACCESSORY

Silicon carbide paper	MLP-SZD□□ *	50 pcs/box, select granularity: 120, 180, 240, 400, 600, 800, 1000, 1200, 1500, 2000
Polishing cloth	MLP-CT6	15 pcs/box, long velvet silk material
Diamond polishing liquid	MLP-DLA□□ *	500ml, select granularity (µm): W40, W28, W20, W14, W9, W7, W5, W3.5, W2.5, W1.5, W1.0, W0.5, W0.25
Magnetic pad	MLP-AD1	Ø203mm
Anti-stick disc	MLP-DC1	Ø203mm

* □□ is granularity specification, for example, code MLP-DLA40 stands for 40µm



Universal Testing Machines
Page 276



Digital Spring Testers
Page 277



Universal Push And Pull Testing Machines
Page 277



Force Gages
Page 278-279



Dial Tension Gages
Page 279

ELECTRONIC UNIVERSAL TESTING MACHINE CODE UTM-E50

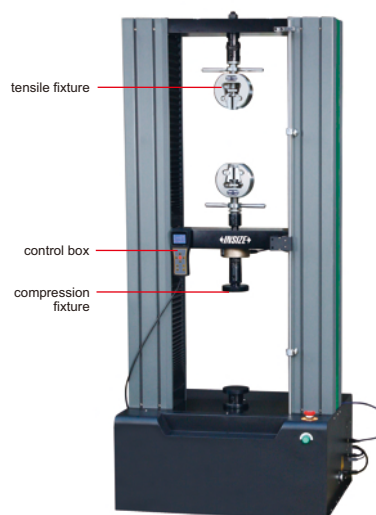
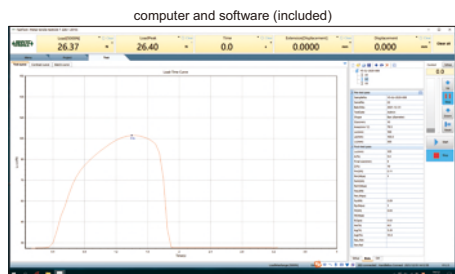

- For tensile, compression, bend, shear, peel, tear tests of metal and non-metal materials

SPECIFICATION

Max. test force	50kN
Accuracy class	0.5 class
Test force measurement range	0.2%~100%FS
Test force measurement accuracy	±0.5% of indicating value
Resolution of test force measurement	1/300000 of Max. test force (same resolution all the way)
Deformation measurement range	0.2%~100%FS
Deformation measurement accuracy	±0.5% of indicating value
Deformation measurement resolution	1/200000 of Max. deformation, up to 1/300000
Large deformation measurement range	10~800mm
Large deformation measurement accuracy	±1% of indicating value
Large deformation measurement resolution	8μm
Displacement accuracy	±0.5% of indicating value
Displacement resolution	0.01mm
Force control speed adjustment range	0.005~5%FS/s
Force control speed control accuracy	±2% of the set value (speed<0.05%FS/s) ±0.5% of the set value (speed≥0.05%FS/s)
Deformation speed adjustment range	0.005~5%FS/s
Deformation speed control accuracy	±2% of the set value (speed<0.05%FS/s) ±0.5% of the set value (speed≥0.05%FS/s)
Beam displacement speed adjustment range	0.001~500mm/min
Beam displacement speed control accuracy	±1% of the set value (speed<0.5mm/min) ±0.2% of the set value (speed≥0.5mm/min)
Crosshead travel *	970mm
Effective compression travel *	700mm
Horizontal test space *	440mm
Power supply	220V, 50Hz, 0.4kW~1kW
Demension	820×620×1880mm
Weight	350kg

*Can be customized according to test requirements



V-shaped jaws (included)



flat jaws (included)

STANDARD DELIVERY

Main unit	1 pc
Control box	1 pc
Computer	1 pc
Measuring software	1 pc
Printer	1 pc
Wedge tension fixture (including flat jaws and V-shaped jaws)	1 set
Compression fixture	1 set

OPTIONAL ACCESSORY

Extensometer	refer to details
Fixtures	refer to details

DIGITAL SPRING TESTERS

- Peak hold and automatic release function
- Set upper and lower limits, red and green indicator and buzzer alarm
- Automatic conversion of three units: N, kgf, lbf
- Built in printer
- Automatic power off

DATA
OUTPUT

VIDEO

STANDARD DELIVERY

Main unit	1 pc
-----------	------

SPECIFICATION

Code	ISF-S10	ISF-S20	ISF-S30	ISF-S50	ISF-S100	ISF-S200
Maximum load	10N	20N	30N	50N	100N	200N
Resolution	0.001N	0.002N	0.01N	0.01N	0.02N	0.05N
Range of digital scale	65mm	65mm	65mm	95mm	95mm	95mm
Resolution of digital scale	0.01mm	0.01mm	0.01mm	0.01mm	0.01mm	0.01mm
Disk diameter	Ø30mm	Ø30mm	Ø30mm	Ø49mm	Ø49mm	Ø49mm
Maximum free length of spring	65mm	65mm	65mm	95mm	95mm	95mm
Measuring range of force	5%~100% (maximum load)					
Accuracy of force	±1% (maximum load)					
Data output	RS232					
Power supply	220V, 50/60Hz					
Dimension	300×235×600mm	300×235×600mm	300×235×600mm	300×235×620mm	300×235×620mm	300×235×620mm
Weight	13.2kg	13.2kg	13.2kg	17.3kg	19.1kg	19.1kg

Code	ISF-S300	ISF-S500	ISF-S1000	ISF-S2000	ISF-S5000
Maximum load	300N	500N	1000N	2000N	5000N
Resolution	0.1N	0.1N	0.2N	0.5N	1N
Range of digital scale	95mm	95mm	150mm	150mm	150mm
Resolution of digital scale	0.01mm	0.01mm	0.01mm	0.01mm	0.01mm
Disk diameter	Ø49mm	Ø49mm	Ø108mm	Ø108mm	Ø108mm
Maximum free length of spring	95mm	95mm	200mm	200mm	200mm
Measuring range of force	5%~100% (maximum load)				
Accuracy of force	±1% (maximum load)				
Data output	RS232				
Power supply	220V, 50/60Hz				
Dimension	300×235×620mm	300×235×620mm	490×300×920mm	490×300×920mm	490×300×920mm
Weight	19.1kg	20.8kg	47.5kg	47.5kg	47.5kg

UNIVERSAL PUSH AND PULL TESTING MACHINES

- Set force, set positioning and set deformation testing modes
- Protective functions of built-in mechanical limit, overload auto stop and emergency stop
- Dual-speed preset, high-speed approximation and low-speed acquisition
- Automatic back to start location after the test
- Can save 10 sets of test value and 3 sets of curve, test reports can be printed by built-in printer
- Display peak value, real-time value and process curve simultaneously
- Auto calibration of displacement zero
- Unit: lbf, N, kgf, ozf
- Auto power off (the time can be set)



ISF-U202



VIDEO

STANDARD DELIVERY

Main unit	1 pc
Adapter	2 pcs

SPECIFICATION

Code	ISF-U055	ISF-U101	ISF-U202
Max. test force	500N	1000N	2000N
Resolution of force	0.05N	0.1N	0.02N
Test force measurement range	1%~100%FS		
Test force measurement accuracy	±1%FS (test force<10%FS) ±0.5%FS (test force≥10%FS)		
Range of adjustable speed	0.5~500mm/min		
Speed accuracy	±2%FS (speed<10%FS) ±1%FS (speed≥10%FS)		
Displacement resolution	0.001mm		
Displacement travel	300mm	450mm	450mm
Displacement accuracy	±0.4mm		
Unit	lbf, N, kgf, ozf		
Pressure plate size	Ø80mm		
Power supply	AC 220V, 50/60Hz		
Dimension	420×250×700mm	365×305×915mm	365×305×915mm
Weight	29.4kg	40kg	40kg

DIGITAL FORCE GAGES



DATA
OUTPUT



ISF-1DF100

- Push and pull test
- Units: lbf, ozf, N, gf, kgf
- 500 memories
- Automatic power off
- Metal case
- LCD display with backlight
- The display flips over when the bottom faces up
- Overload alarm



software flash disk
(included)



printer (optional)

SPECIFICATION

Code	ISF-1DF10	ISF-1DF50	ISF-1DF100	ISF-1DF500	ISF-1DF1000
Load capacity (N)	10	50	100	500	1000
Resolution (N)	0.01	0.01	0.1	0.1	1
Accuracy	±0.3% (of load capacity)				
Measuring mode	tracking, peak (max.), tolerance testing				
Power supply	built-in rechargeable battery				
Dimension	150×73×33mm				
Weight	450g				

STANDARD DELIVERY

Main unit	1 pc
AC/DC adapter	1 pc
Software and USB cable	1 pc
Push/pull accessory	6 pcs (flat push tip, V-type push tip, knife-edge push tip, point push tip, pull clamp, extension rod)

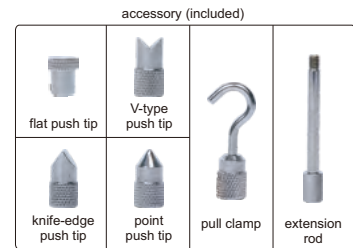

accessory (included)

OPTIONAL ACCESSORY

Printer	ISF-DF-PRINTER
Test stand	ISF-MT1K

TEST STAND FOR DIGITAL FORCE GAGE CODE ISF-MT1K



force gage
is optional

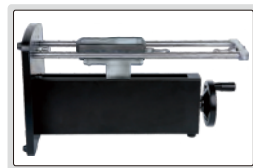

horizontal orientation test



digital scale (optional)

- For digital force gages (code ISF-1DF□□ and ISF-DF□□)
- To be used in vertical and horizontal orientation

SPECIFICATION

Load capacity	1000N
Travel	200mm (3mm vertical movement per revolution of handwheel)
Dimension	196×250×446mm
Weight	13kg

OPTIONAL ACCESSORY

Digital scale (range: 200mm, resolution: 0.01mm/0.0005")	ISF-MT1K-SCALE
--	----------------

TEST STAND FOR FORCE GAGE CODE ISF-MT500

force gage
is optional



horizontal orientation test

- For force gages (code ISF-F□□□)
- To be used in vertical and horizontal orientation

SPECIFICATION

Load capacity	500N
Travel	150mm (3mm vertical movement per revolution of handwheel)
Dimension	160×240×460mm
Weight	12kg

FORCE GAGES

- Push and pull test
- Peak (max.) or tracking mode



VIDEO

SPECIFICATION

Code		ISF-F10	ISF-F20	ISF-F30	ISF-F50	ISF-F100	ISF-F200	ISF-F300	ISF-F500
Capacity	N	10	20	30	50	100	200	300	500
	kgf	1	2	3	5	10	20	30	50
Graduation	N	0.05	0.1	0.2	0.25	0.5	1	2	2.5
Accuracy	±1% (of load capacity)								



ISF-F500

STANDARD DELIVERY

Main unit	1 pc
Push tip	4 pcs (flat, V-type, knife-edge, point)
Pull clamp	1 pc
Extension rod	1 pc

OPTIONAL ACCESSORY

Test stand	ISF-MT500
------------	-----------

accessory (included)

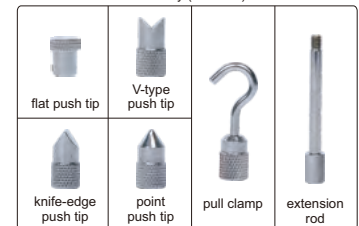

MANUAL STRIPPING FORCE TEST STANDS

- For stripping force test with force gages



VIDEO

SPECIFICATION

Code	ISF-P30A	ISF-P30D
Apply to	dial force gages (code ISF-F□□□)	digital force gages (code ISF-1DF□□□ and ISF-DF□□□)
Load capacity	500N	
Horizontal travel	170mm	
Dimension	420×215×480mm	
Weight	22kg	

force gage is optional

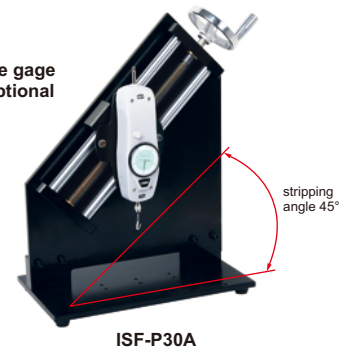

ISF-P30A

DIAL TENSION GAGES

- Clockwise and counter-clockwise use
- For electronic and precision mechanical industry, such as test the contact pressure of relay, adjust the tension or compression of spring



VIDEO

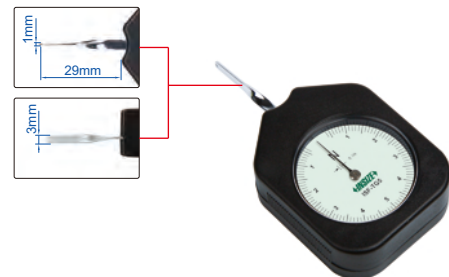

ISF-TG5

SPECIFICATION (Unit: N)

Code	ISF-TGD1	ISF-TGD3	ISF-TGD5	ISF-TG1	ISF-TG5
Range (N)	0.01~0.1	0.03~0.3	0.05~0.5	0.1~1	0.5~5
Graduation (N)	0.002	0.005	0.01	0.02	0.1
Accuracy	±2% (full scale)				
Dimension (L×W×H)	90×47×19mm				
Weight	60g				

34

TORQUE TESTERS TORQUE WRENCHES

←INSIZE→



Digital Torque Testers
Page 281



Torque Screwdrivers
Page 281



Torque Wrenches
Page 282-287

DIGITAL TORQUE TESTERS

ATTENTION: NOT SUITABLE FOR ELECTRIC WRENCHES, IMPACT WRENCHES OR PNEUMATIC WRENCHES



- Test torque wrenches, torque screwdrivers and other torque tools
- Clockwise operation
- Peak, track and first peak working modes
- Tolerance testing
- LED indicator for target torque alarm:
 - Green LED light on when the value is within tolerance;
 - Red LED light on when the value is above the high tolerance
- Power off automatically in 2 minutes without any operations



**IST-04TT350
type A**



**IST-04TT815
type B**

SPECIFICATION

Code	IST-04TT5	IST-04TT28	IST-04TT68	IST-04TT350	IST-04TT815	IST-04TT1000	IST-04TT2000
Type	A				B		
Range	0.5~5N.m	2.8~28N.m	6.8~68N.m	35~350N.m	81.5~815N.m	100~1000N.m	200~2000N.m
Accuracy	±1% (clockwise)						
Resolution	0.001N.m	0.01N.m	0.01N.m	0.1N.m	0.1N.m	1N.m	1N.m
Unit	N.m, in.lb, ft.lb, kg.cm					N.m, ft.lb	
Square socket/hex driver	1/4"	3/8"	3/8"	1/2"	27mm	27mm	27mm
Adaptor	no	3/8" to 1/4"	3/8" to 1/4"	1/2" to 3/8" 3/8" to 1/4"	no		
Power supply	DC						
Weight	0.75kg	0.75kg	1.1kg	1.1kg	5.1kg	5.1kg	5.1kg

STANDARD DELIVERY

Main unit	1 pc
AC/DC adapter	1 pc
Adaptor	refer to details



adaptor
(type A included)

TORQUE SCREWDRIVERS

ATTENTION: CLOCKWISE OPERATION ONLY



IST-MG100

SPECIFICATION

Code	IST-MG100	IST-MG250	IST-MG360	IST-MG600
Range (clockwise)	20~100cN.m	50~250cN.m	60~360cN.m	1.0~6.0N.m
Graduation	2cN.m	5cN.m	5cN.m	0.1N.m
Head	1/4" hex socket			
Accuracy	±6%			
Length	172mm			
Weight	0.26kg			

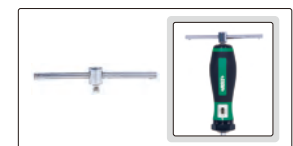

T-bar wrench (for IST-MG250, IST-MG360, IST-MG600)

STANDARD DELIVERY

Torque screwdriver	1 pc
T-bar wrench (for IST-MG250, IST-MG360, IST-MG600)	1 pc

DIGITAL TORQUE WRENCHES

OPTIONAL ACCURACY:
 CLOCKWISE: $\pm 1\%$
 COUNTER-CLOCKWISE: $\pm 2\%$
 ONLY FOR RANGE 6~850N.m

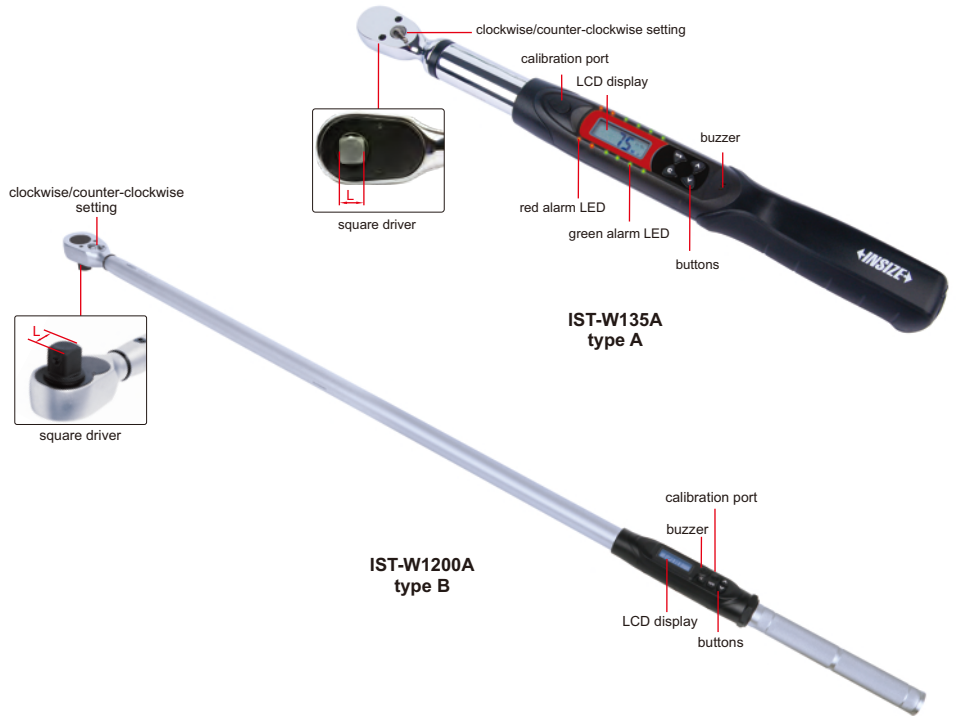

- Clockwise and counter-clockwise operation
- Unit: N.m, in.lb, ft.lb, kg.cm
- Peak and track working mode
- Target torque value can be set, with audible and visible alarm:
 - Green LED light on and buzzer sounds when torque value is 90%~100% of target torque
 - Both green and red LED light on and buzzer sounds when target torque value is reached
- Power off automatically in 5 minutes without any operations
- Non-slip grip handle
- With damp record
- With overload record (once the torque reaches 110% of the maximum range)

SPECIFICATION

Code	Type	Range	Accuracy	Resolution	Square driver (L)	Power supply	Length	Weight
IST-W30A	A	6~30N.m	clockwise: $\pm 2\%$ counter-clock wise: $\pm 3\%$	0.01N.m	1/4"	2×AA batteries, for 110 hours working	390mm	830g
IST-W135A		27~135N.m		0.1N.m	3/8"		415mm	950g
IST-W200A		40~200N.m		0.1N.m	1/2"		530mm	1.4kg
IST-W340A		68~340N.m		0.1N.m	1/2"		650mm	1.6kg
IST-W500A *	B	100~500N.m	clockwise: $\pm 2.5\%$ counter-clock wise: $\pm 3.5\%$	0.1N.m	3/4"		1285mm	7kg
IST-W850A		170~850N.m		0.1N.m	3/4"		1295mm	6kg
IST-W1200A		240~1200N.m		1N.m	1"		1920mm	13kg
IST-W1500A		300~1500N.m		1N.m	1"		1920mm	13kg
IST-W2000A		400~2000N.m		1N.m	1"		1920mm	14kg

* The accuracy of this code is not optional

OPTIONAL ACCESSORY

Calibration cable IST-W-CABLE

INTERCHANGEABLE HEAD DIGITAL TORQUE WRENCHES



OPTIONAL ACCURACY:
 CLOCKWISE: $\pm 1\%$
 COUNTER-CLOCKWISE: $\pm 2\%$

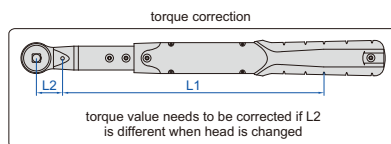

- Clockwise and counter-clockwise operation
- Unit: N.m, in.lb, ft.lb, kg.cm, degree
- Peak and track working modes
- Target torque value can be set, with audible and visible alarm:
 - Green LED light on and buzzer sounds when torque value is 90%~100% of target torque
 - Both green and red LED light on and buzzer sounds when target torque value is reached
- Power off in 5 minutes automatically without any operations
- Non-slip grip handle
- With damp record
- With overload record (once the torque reaches 110% of the maximum range)



IST-2W135A

To be continued

Continued from previous page

SPECIFICATION

Code	IST-2W30A	IST-2W135A	IST-2W200A	IST-2W340A	IST-2W410A
Range	6~30N.m	27~135N.m	40~200N.m	68~340N.m	82~410N.m
Accuracy	clockwise	±2%			
	counter-clockwise	±3%			
Resolution	0.01N.m	0.1N.m	0.1N.m	0.1N.m	0.1N.m
Socket size (A×B)	12×9mm	12×9mm	18×14mm	18×14mm	18×14mm
Arm length (L1)	272.7mm	287.7mm	381.2mm	501.2mm	501.2mm
Power supply	2xAA batteries, for 110 hours working				
Weight	1400g	1570g	2170g	2320g	2320g

RATCHET HEAD (INCLUDED) SPECIFICATION

Code of torque wrench	IST-2W30A	IST-2W135A	IST-2W200A	IST-2W340A	IST-2W410A
Square driver (D)	1/4"	3/8"	1/2"	1/2"	3/4"
Length (L2)	29mm	29mm	40mm	40mm	40mm

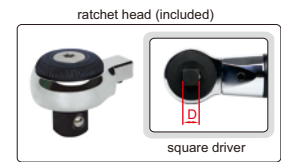

STANDARD DELIVERY

Torque wrench	1 pc
Ratchet head	1 pc

OPTIONAL ACCESSORY

Calibration cable	IST-W-CABLE
Interchangeable head	refer to details



RATCHET HEAD (optional)

Code	Square driver (D)	Applicable wrenches
IST-2W-R1	1/4"	IST-2W30A
IST-2W-R2	3/8"	IST-2W135A
IST-2W-R3	1/2"	IST-2W135A
IST-2W-R4	1/2"	IST-2W200A IST-2W340A IST-2W410A



ADJUSTABLE SPANNER HEAD (optional)

Code	Open size	Applicable wrenches
IST-2W-A1	5~27mm	IST-2W30A IST-2W135A
IST-2W-A2	5-30mm	IST-2W-200A IST-2W-410A
IST-2W-A3	10-41mm	IST-2W-340A IST-2W-410A

OPEN END HEAD (optional)

Code	Open size	Applicable wrenches	
IST-2W-K7	7mm	IST-2W30A IST-2W135A	
IST-2W-K8	8mm		
IST-2W-K9	9mm		
IST-2W-K10	10mm		
IST-2W-K11	11mm		
IST-2W-K12	12mm		
IST-2W-K13	13mm		
IST-2W-K14	14mm		
IST-2W-K15	15mm		
IST-2W-K16	16mm		
IST-2W-K17	17mm		
IST-2W-K18	18mm		
IST-2W-K19	19mm		
IST-2W-K13A	13mm		IST-2W200A IST-2W340A IST-2W410A
IST-2W-K14A	14mm		
IST-2W-K15A	15mm		
IST-2W-K16A	16mm		
IST-2W-K17A	17mm		
IST-2W-K18A	18mm		
IST-2W-K19A	19mm		
IST-2W-K21A	21mm		
IST-2W-K22A	22mm		
IST-2W-K24A	24mm		
IST-2W-K27A	27mm		

BOX END HEAD (optional)

Code	Open size	Applicable wrenches	
IST-2W-M7	7mm	IST-2W30A IST-2W135A	
IST-2W-M8	8mm		
IST-2W-M10	10mm		
IST-2W-M11	11mm		
IST-2W-M12	12mm		
IST-2W-M13	13mm		
IST-2W-M14	14mm		
IST-2W-M15	15mm		
IST-2W-M16	16mm		
IST-2W-M17	17mm		
IST-2W-M18	18mm		
IST-2W-M19	19mm		
IST-2W-M21	21mm		
IST-2W-M22	22mm		
IST-2W-M13A	13mm		IST-2W200A IST-2W340A
IST-2W-M14A	14mm		
IST-2W-M15A	15mm		
IST-2W-M16A	16mm		
IST-2W-M17A	17mm		
IST-2W-M18A	18mm		
IST-2W-M19A	19mm		
IST-2W-M21A	21mm		

DIGITAL TORQUE WRENCHES (KEYBOARD SIGNAL)

BUILT-IN BLUETOOTH

TYPE B OPTIONAL ACCURACY:
CLOCKWISE: ±1%
COUNTER-CLOCKWISE: ±2%



INSPECTION
CERTIFICATE



IST-15W12A
type A



IST-15W135A
type B

Torque wrenches:

- Unit: in.lb, ft.lb, N.m, kg.cm
- Clockwise and counter-clockwise operation
- Peak and track working mode
- Can set tolerance with judgement in peak working mode
- 9 target torque values can be set, with audible and visible alarm:
LED lights up in sequence, and the buzzer gets louder and louder when torque value is 80%~99.5% of target torque
- Memory of 2000 results
- Power off in 2 minutes automatically
- Non-slip grip handle
- With overload record (once the torque reaches 110% of the maximum range)

Data transmission:

- Built-in Bluetooth 4.0 module, which can be connected with computers (with Bluetooth function), mobile phones, tablets and other devices
- Keyboard signal, can be transmitted to Excel, Word, TXT
- Transmission distance is 10 meters (no obstacles, no electromagnetic interference)
- Bluetooth connection and disconnection are respectively shown by indicator lights



transmission distance is 10 meters
(no obstacles, no electromagnetic interference)

SPECIFICATION

Code	IST-15W06A	IST-15W12A	IST-15W20A	IST-15W30A	IST-15W135A	IST-15W200A	IST-15W340A
Type	A (short handle)			B (long handle)			
Range	1.2~6N.m	2.4~12N.m	4~20N.m	6~30N.m	27~135N.m	40~200N.m	68~340N.m
Accuracy	clockwise	±2%					
	counter-clockwise	±3%					
Tolerance setting range	-20%~+20% (target torque value)						
Resolution	0.001N.m	0.01N.m	0.01N.m	0.01N.m	0.1N.m	0.1N.m	0.1N.m
Square driver (L)	1/4"	1/4"	1/4"	1/4"	3/8"	1/2"	1/2"
Power supply	2xAAA batteries			2xAA batteries			
Length	215mm	215mm	215mm	390mm	415mm	530mm	650mm
Weight	750g	750g	750g	760g	940g	1340g	1540g

OPTIONAL ACCESSORY

Calibration cable IST-SD-CABLE

TORQUE WRENCHES



ATTENTION: CLOCKWISE
OPERATION ONLY



- According to DIN ISO 6789, ASME B107.300
- All-metal construction, sturdy and durable

IST-9WM335

SPECIFICATION

Code	IST-9WM12	IST-9WM20	IST-9WM30	IST-9WM60	IST-9WM100	IST-9WM125	IST-9WM200
Range (clockwise)	2.5~12N.m	4~20N.m	6~30N.m	10~60N.m	20~100N.m	25~125N.m	40~200N.m
Accuracy	±6% (<10N.m) ±4% (≥10N.m)	±6% (<10N.m) ±4% (≥10N.m)	±6% (<10N.m) ±4% (≥10N.m)	±4%	±4%	±4%	±4%
Graduation	0.1N.m	0.1N.m	0.2N.m	0.5N.m	0.5N.m	0.5N.m	1N.m
Square driver (D)	1/4"	1/4"	3/8"	3/8"	1/2"	1/2"	1/2"
Length	290mm	290mm	318mm	388mm	443mm	443mm	468mm
Weight	680g	680g	820g	960g	1040g	1040g	1160g

Code	IST-9WM335	IST-9WM500	IST-9WM800	IST-9WM1000	IST-9WM1500	IST-9WM2000	IST-9WM3000
Range (clockwise)	65~335N.m	100~500N.m	160~800N.m	200~1000N.m	300~1500N.m	400~2000N.m	600~3000N.m
Accuracy	±4%	±4%	±4%	±4%	±4%	±4%	±4%
Graduation	1N.m	2.5N.m	4N.m	5N.m	5N.m	10N.m	15N.m
Square driver (D)	1/2"	3/4"	3/4"	3/4"	1"	1"	1"
Length	528mm	855mm	1055mm	1055mm	1260mm	1260mm	1260mm
Weight	1300g	5000g	5900g	5900g	9200g	9200g	10500g

INTERCHANGEABLE HEAD TORQUE WRENCHES

ATTENTION: CLOCKWISE
OPERATION ONLY



- According to DIN ISO 6789, ASME B107.300
- All-metal construction, sturdy and durable

IST-11WM200

SPECIFICATION

Code	Range (clockwise)	Accuracy	Graduation	Socket size (A×B)	Length	Weight
IST-11WM12	2.5~12N.m	±6% (<10N.m), ±4% (≥10N.m)	0.05N.m	12×9mm	284mm	580g
IST-11WM30	6.0~30N.m	±6% (<10N.m), ±4% (≥10N.m)	0.1N.m	12×9mm	303mm	720g
IST-11WM60	10~60N.m	±4%	0.5N.m	12×9mm	372mm	860g
IST-11WM125	25~125N.m	±4%	0.5N.m	12×9mm	427mm	940g
IST-11WM200	40~200N.m	±4%	1N.m	18×14mm	460mm	1060g
IST-11WM335	65~335N.m	±4%	1N.m	18×14mm	520mm	1200g
IST-11WM500	100~500N.m	±4%	2.5N.m	32×24mm	855mm	5000g
IST-11WM800	160~800N.m	±4%	4N.m	32×24mm	1055mm	5900g
IST-11WM1000	200~1000N.m	±4%	5N.m	32×24mm	1055mm	5900g
IST-11WM1500	300~1500N.m	±4%	5N.m	36×27mm	1249mm	9000g
IST-11WM2000	400~2000N.m	±4%	10N.m	36×27mm	1249mm	9000g
IST-11WM3000	600~3000N.m	±4%	15N.m	36×27mm	1249mm	10300g

To be continued

Continued from previous page

RATCHET HEAD (optional)

Code	Square driver	Applicable wrenches
IST-11WM-R1	1/4"	IST-11WM12 IST-11WM30
IST-11WM-R2	3/8"	IST-11WM12, IST-11WM30 IST-11WM60, IST-11WM125
IST-11WM-R3	1/2"	IST-11WM200 IST-11WM335
IST-11WM-R4 *	3/4"	IST-11WM200 IST-11WM335
IST-11WM-R5	3/4"	IST-11WM500, IST-11WM800 IST-11WM1000
IST-11WM-R6	1"	IST-11WM1500, IST-11WM2000 IST-11WM3000



HOOK HEAD (optional)

Hook head	customized according to customer requirements
------------------	---



OPEN END HEAD (optional)

Code	Open size	Applicable wrenches
IST-11WM-K8	8mm	IST-11WM12 IST-11WM30 IST-11WM60 IST-11WM125
IST-11WM-K10	10mm	
IST-11WM-K13	13mm	
IST-11WM-K14	14mm	
IST-11WM-K15	15mm	
IST-11WM-K17	17mm	
IST-11WM-K19 *	19mm	
IST-11WM-K13A	13mm	IST-11WM200 IST-11WM335
IST-11WM-K14A	14mm	
IST-11WM-K15A	15mm	
IST-11WM-K17A	17mm	
IST-11WM-K19A	19mm	
IST-11WM-K22A	22mm	
IST-11WM-K24A	24mm	
IST-11WM-K27A *	27mm	
IST-11WM-K30A *	30mm	
IST-11WM-K32A *	32mm	
IST-11WM-K22B	22mm	IST-11WM500 IST-11WM800 IST-11WM1000
IST-11WM-K24B	24mm	
IST-11WM-K27B	27mm	
IST-11WM-K28B	28mm	
IST-11WM-K30B	30mm	
IST-11WM-K32B	32mm	
IST-11WM-K33B *	33mm	
IST-11WM-K36B *	36mm	
IST-11WM-K38B *	38mm	
IST-11WM-K40B *	40mm	
IST-11WM-K30C	30mm	IST-11WM1500 IST-11WM2000 IST-11WM3000
IST-11WM-K32C	32mm	
IST-11WM-K34C	34mm	
IST-11WM-K36C	36mm	
IST-11WM-K38C	38mm	
IST-11WM-K41C	41mm	
IST-11WM-K45C	45mm	
IST-11WM-K50C *	50mm	
IST-11WM-K55C *	55mm	
IST-11WM-K60C *	60mm	

BOX END HEAD (optional)

Code	Open size	Applicable wrenches
IST-11WM-M8	8mm	IST-11WM12 IST-11WM30 IST-11WM60 IST-11WM125
IST-11WM-M10	10mm	
IST-11WM-M13	13mm	
IST-11WM-M14	14mm	
IST-11WM-M15	15mm	
IST-11WM-M17	17mm	
IST-11WM-M19	19mm	
IST-11WM-M13A	13mm	IST-11WM200 IST-11WM335
IST-11WM-M14A	14mm	
IST-11WM-M15A	15mm	
IST-11WM-M17A	17mm	
IST-11WM-M19A	19mm	
IST-11WM-M22A	22mm	
IST-11WM-M24A	24mm	
IST-11WM-M27A	27mm	
IST-11WM-M30A	30mm	
IST-11WM-M32A	32mm	
IST-11WM-M22B	22mm	IST-11WM500 IST-11WM800 IST-11WM1000
IST-11WM-M24B	24mm	
IST-11WM-K27B	27mm	
IST-11WM-M28B	28mm	
IST-11WM-M30B	30mm	
IST-11WM-M32B	32mm	
IST-11WM-M33B	33mm	
IST-11WM-M36B *	36mm	
IST-11WM-M38B *	38mm	
IST-11WM-M40B	40mm	
IST-11WM-M30C	30mm	IST-11WM1500 IST-11WM2000 IST-11WM3000
IST-11WM-M32C	32mm	
IST-11WM-M34C	34mm	
IST-11WM-M36C	36mm	
IST-11WM-M38C	38mm	
IST-11WM-M41C	41mm	
IST-11WM-M45C	45mm	
IST-11WM-M50C	50mm	
IST-11WM-M55C *	55mm	
IST-11WM-M60C *	60mm	

*Torque value needs to be corrected for these heads



MECHANICAL TORQUE WRENCHES (DIGITAL SETTING)

ATTENTION: DISPLAY PRE-SET TORQUE VALUE (NOT REAL TIME TORQUE)

ATTENTION: CLOCKWISE OPERATION ONLY

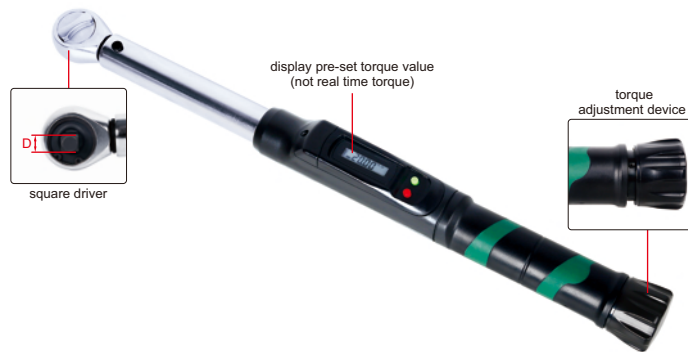

IST-19WM100

- Unit: N.m, in.lb, ft.lb, kg.cm
- Mechanical "click" torque wrench, the pre-set torque value is shown on the display

SPECIFICATION

Code	IST-19WM60	IST-19WM100	IST-19WM140	IST-19WM200	IST-19WM300
Range (clockwise)	6~60N.m	10~100N.m	14~140N.m	20~200N.m	30~300N.m
Accuracy	±3%	±3%	±3%	±3%	±3%
Graduation	0.1N.m	0.1N.m	0.1N.m	0.1N.m	0.1N.m
Square driver (D)	3/8"	3/8"	1/2"	1/2"	1/2"
Length	382mm	450mm	481mm	520mm	585mm
Weight	1.3kg	1.4kg	1.45kg	1.6kg	1.8kg

DIAL TORQUE WRENCHES



IST-DW70

- Clockwise and counter-clockwise operation
- According to DIN ISO 6789, ASME B107.300

SPECIFICATION

Code	IST-DW1D8	IST-DW3D5	IST-DW9	IST-DW18	IST-DW35	IST-DW70	IST-DW140	IST-DW240	IST-DW350	IST-DW480
Range	0.36~1.8N.m 3~16in.lb	0.7~3.5N.m 6~30in.lb	1.8~9N.m 15~75in.lb	3.6~18N.m 30~150in.lb	7~35N.m 60~300in.lb	14~70N.m 120~600in.lb	28~140N.m 20~100ft.lb	48~240N.m 35~175ft.lb	70~350N.m 50~250ft.lb	96~480N.m 70~350ft.lb
Accuracy	±3%	±3%	±3%	±3%	±3%	±3%	±3%	±3%	±3%	±3%
Graduation	0.02N.m 0.2in.lb	0.05N.m 0.5in.lb	0.1N.m 1in.lb	0.2N.m 2in.lb	0.5N.m 5in.lb	1N.m 10in.lb	2N.m 1ft.lb	3N.m 2.5ft.lb	2.5N.m 2.5ft.lb	6N.m 5ft.lb
Square driver (D)	1/4"	1/4"	1/4"	3/8"	3/8"	3/8"	1/2"	1/2"	1/2"	3/4"
Length	254mm	254mm	254mm	254mm	254mm	378mm	546mm	546mm	546mm	708mm
Weight	480g	480g	480g	480g	480g	820g	1300g	1300g	1300g	4030g



Electronic Balances
Page 289-291



Weighing Scales
Page 292/294



Counting Scales
Page 293



Electronic Pocket Scales
Page 293



Platform Scales
Page 294



Floor Scales
Page 295



Electronic Crane Scales
Page 296-297



Moisture Analyzers
Page 297



Weight Sets
Page 298

ELECTRONIC BALANCES (0.1mg)

DATA OUTPUT



calibration weight
(included in 8310-120M,
8310-210M and 8310-320M)



printer (optional)

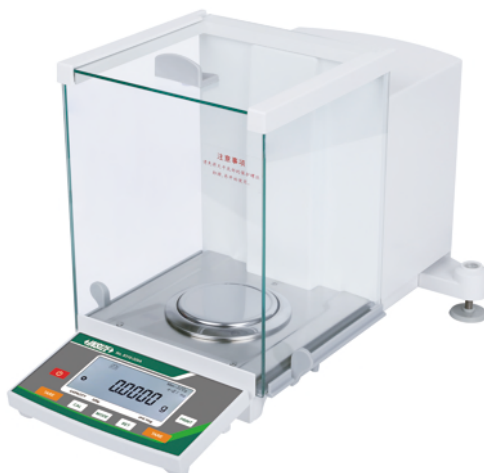

8310-320A

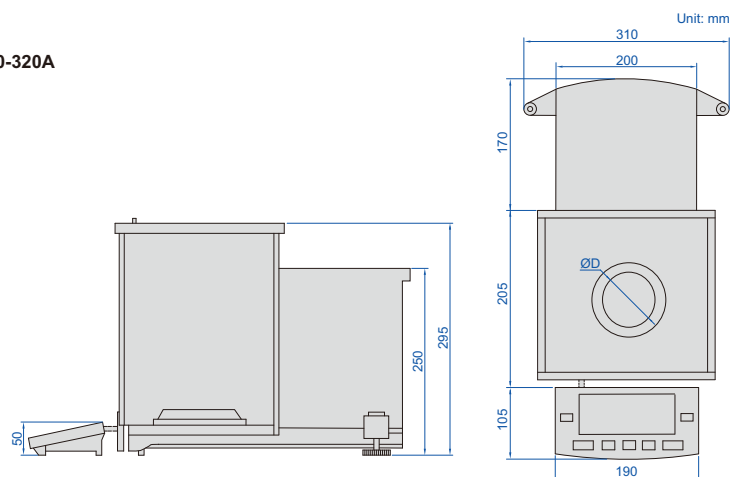

- Rear electromagnetic sensor
- Separated display unit and weighing unit, reduce vibration error
- Digital processing technology improves reading stability and response speed for micro sample addition, sample weight and balance reading is consistent
- Unit: g, oz, ct, lb
- Weighing, counting, taring, percentage
- Data output

SPECIFICATION

Code	8310-120M	8310-210M	8310-320M	8310-120A	8310-210A	8310-320A
Calibration	external calibration			internal calibration		
Maximum weighing	120g	210g	320g	120g	210g	320g
Minimum weighing	10mg	10mg	10mg	10mg	10mg	10mg
Resolution (d)	0.1mg	0.1mg	0.1mg	0.1mg	0.1mg	0.1mg
Verification interval (e)	1mg	1mg	1mg	1mg	1mg	1mg
Accuracy (m is load)	m≤50g: ±0.5mg; 50g<m≤200g: ±1mg; m>200g: ±1.5mg			m≤50g: ±0.5mg; 50g<m≤200g: ±1mg; m>200g: ±1.5mg		
Repeatability	±0.1mg					
Linearity	±0.1mg					
Stabilization time	2.5s					
Weighing pan size (ØD)	Ø90mm					
Output	RS232					
Operation temperature	10~30°C					
Operation humidity	20~85% RH					
Power supply	power adapter (12V/2A)					
Dimension (L×W×H)	480×310×320mm					
Weight	6kg					

OPTIONAL ACCESSORY

RS232 cable	8304-CABLE *
Printer	8303-PRINTER

*Used to connect with computers

ELECTRONIC BALANCES (0.1mg)

DATA OUTPUT

- Electromagnetic sensor
- Unit: g, ct, oz, lb
- Weighing, counting, taring
- Data output

SPECIFICATION

Code	8304-120	8304-220
Maximum weighing	120g	220g
Minimum weighing	10mg	10mg
Resolution (d)	0.1mg	0.1mg
Verification interval (e)	1mg	1mg
Accuracy (m is load)	m≤50g: ±0.5mg; 50g<m≤120g: ±1mg	m≤50g: ±0.5mg; 50g<m≤200g: ±1mg; m>200g: ±1.5mg
Weighing pan size (ØD)	Ø90mm	
Operation temperature	10~30°C	
Operation humidity	20~85% RH	
Power supply	power adapter (12V/2A)	
Dimension (L×W×H)	230×310×320mm	



8304-120



calibration weight (included)



printer (optional)

OPTIONAL ACCESSORY

RS232 cable	8304-CABLE*
Printer	8303-PRINTER
Data output cable (keyboard format)	7302-8304

*Used to connect with computers

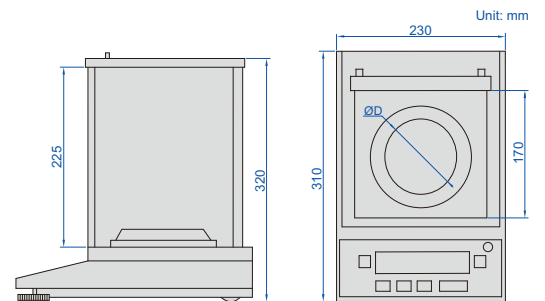

ELECTRONIC BALANCES (1mg)

DATA OUTPUT

- Aluminum alloy shell, wind shield, three side glass sliding doors
- Electromagnetic balance sensor
- Unit: g, ct, ozt, oz, gn, dwt, mg
- Weighing, counting, taring
- Data output
- With a hook at the bottom



8303-520



printer (optional)



calibration weight (included)

SPECIFICATION

Code	8303-220	8303-320	8303-520	8303-620	8303-1020
Maximum weighing	220g	320g	520g	620g	1020g
Minimum weighing	20mg	20mg	100mg	100mg	100mg
Resolution (d)	1mg	1mg	1mg	1mg	1mg
Verification interval (e)	10mg	10mg	10mg	10mg	10mg
Accuracy	load capacity≤500g: ±5mg; load capacity>500g: ±10mg				
Weighing pan size (ØD)	Ø80mm				Ø120mm
Operation temperature	15~30°C		18~23°C		
Operation humidity	40%~80% RH		50%~70% RH		
Power supply	220V, 50/60Hz				
Dimension (L×W×H)	330×210×340mm				

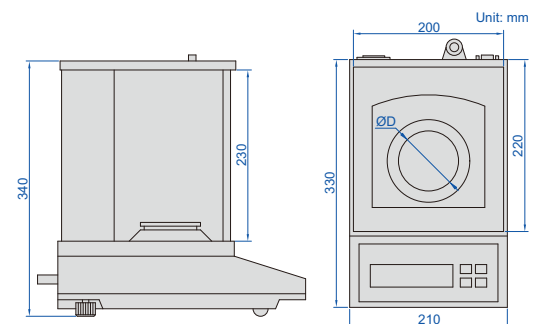

OPTIONAL ACCESSORY

RS232 cable	8301-CABLE*
Printer	8303-PRINTER

*Used to connect with computers

ELECTRONIC BALANCES (0.01g)

DATA
OUTPUT



8305-5000

- LCD with back light
- Unit: g, ct, ozt, oz, GN, dwt, lb, kg
- Weighing, counting, taring

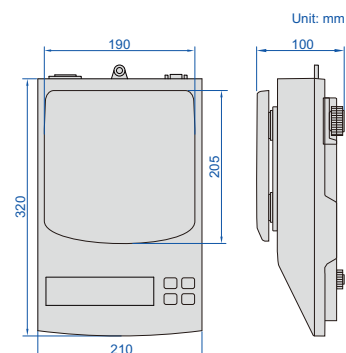

SPECIFICATION

Code	8305-2000	8305-3000	8305-5000	8305-6000
Maximum weighing	2kg	3kg	5kg	6kg
Minimum weighing	0.2g	0.2g	0.2g	0.2g
Resolution (d)	0.01g	0.01g	0.01g	0.01g
Verification interval (e)	0.1g	0.1g	0.1g	0.1g
Accuracy (m is load)	m≤0.5kg: ±0.05g; 0.5kg<m≤2kg: ±0.1g	m≤0.5kg: ±0.05g; 0.5kg<m≤2kg: ±0.1g m>2kg: ±0.15g	m≤0.5kg: ±0.05g; 0.5kg<m≤2kg: ±0.1g m>2kg: ±0.15g	m≤0.5kg: ±0.05g; 0.5kg<m≤2kg: ±0.1g m>2kg: ±0.15g
Weighing pan size	190×205mm			
Output	RS232			
Operation temperature	0~40°C			
Operation humidity	≤80% RH			
Power supply	220V, 50/60Hz			
Dimension (L×W×H)	320×210×100mm			



calibration weight
(included in 8305-2000
and 8305-3000)



printer (optional)

OPTIONAL ACCESSORY

RS232 cable	8301-CABLE*
Printer	8303-PRINTER
Data output cable (keyboard format)	7302-8001
Wireless transmitter (receiver is needed)	7315-8301

*Used to connect with computers

ELECTRONIC BALANCES

DATA
OUTPUT

- Automatic zero when power on
- Unit: g (gram), ct (carat), ozt (troy ounce)
- Weighing, counting, taring
- Overload alarm
- Data output



8301-3000

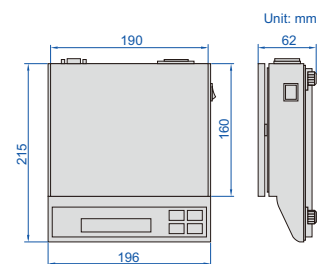

SPECIFICATION

Code	8301-300	8301-600	8301-1200	8301-3000	8301-6000
Maximum weighing	300g	600g	1200g	3000g	6000g
Minimum weighing	0.2g	0.2g	0.2g	2g	2g
Resolution (d)	0.01g	0.01g	0.01g	0.1g	0.1g
Verification interval (e)	0.1g	0.1g	0.1g	1g	1g
Accuracy (m is load)	m≤50g: ±0.05g; 50g<m≤200g: ±0.1g; m>200g: ±0.15g		m≤500g: ±0.5g; 500g<m≤2000g: ±1g; m>2000g: ±1.5g		
Weighing pan size	Ø135mm		190×160mm		
Operation temperature	0~40°C				
Operation humidity	≤80% RH				
Power supply	220V, 50/60Hz				
Dimension (L×W×H)	215×196×62mm				



windshield
(included in 8301-300,
8301-600 and 8301-1200)



calibration weight
(included in 8301-300,
8301-600 and 8301-1200)

OPTIONAL ACCESSORY

RS232 cable	8301-CABLE
Data output cable (keyboard format)	7302-8001
Wireless transmitter (receiver is needed)	7315-8301

WEIGHING SCALES (OIML CERTIFICATE)



- LCD display, with backlight
- Zero-setting, subtracting tare value
- Overload alarm
- Automatic power off
- OIML certificate (No. 0200-NAWI-04601)



8002-30M

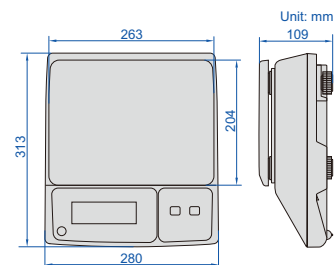

SPECIFICATION

Code	8002-6M	8002-15M	8002-30M	8002-6MD	8002-15MD	8002-30MD
Maximum capacity	3/6kg	6/15kg	15/30kg	3/6kg	6/15kg	15/30kg
Minimum capacity	20g	40g	100g	20g	40g	100g
Resolution (d)	1/2g	2/5g	5/10g	1/2g	2/5g	5/10g
Verification interval (e)	2g	5g	10g	2g	5g	10g
Accuracy (m is load)	m≤3kg: ±1g 3kg<m≤6kg: ±2g	m≤6kg: ±2g 6kg<m≤15kg: ±5g	m≤15kg: ±5g 15kg<m≤30kg: ±10g	m≤3kg: ±1g 3kg<m≤6kg: ±2g	m≤6kg: ±2g 6kg<m≤15kg: ±5g	m≤15kg: ±5g 15kg<m≤30kg: ±10g
Output	no			RS232		
Operation temperature	-10~40°C					
Power	rechargeable battery (6V/3.2Ah), power adapter (12V/500mA)					
Dimensions of pan	263×204mm					

WEIGHING SCALES (HIGH PRECISION)

- LCD display, with backlight
- Zero-setting, subtracting tare value
- Overload alarm
- Automatic power off



8001-30

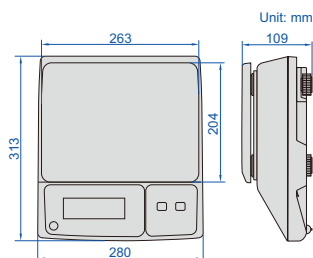

printer (optional)

SPECIFICATION

Code	8001-6	8001-15	8001-30	8001-6D	8001-15D	8001-30D
Maximum weighing	6kg	15kg	30kg	6kg	15kg	30kg
Minimum weighing	4g	10g	20g	4g	10g	20g
Resolution (d)	0.2g	0.5g	1g	0.2g	0.5g	1g
Accuracy (m is load)	m≤1kg: ±1g 1kg<m≤4kg: ±2g m>4kg: ±3g	m≤2.5kg: ±2.5g 2.5kg<m≤10kg: ±5g m>10kg: ±7.5g	m≤5kg: ±5g 5kg<m≤20kg: ±10g m>20kg: ±15g	m≤1kg: ±1g 1kg<m≤4kg: ±2g m>4kg: ±3g	m≤2.5kg: ±2.5g 2.5kg<m≤10kg: ±5g m>10kg: ±7.5g	m≤5kg: ±5g 5kg<m≤20kg: ±10g m>20kg: ±15g
Units	kg, lb			kg		
Output	no			RS232		
Operation temperature	-10~40°C					
Power	rechargeable battery (6V/3.2Ah), power adapter (12V/500mA)					
Dimensions of pan	263×204mm					

OPTIONAL ACCESSORY (for scales with RS232)

Printer	8001-PRINTER
Data output cable (keyboard format)	7302-8001

COUNTING SCALES

- LCD display, with backlight
- Zero-setting, subtracting tare value, counting, accumulation, checking alarm
- Overload alarm
- Units: kg, g, lb, tj, hj, lb-oz



printer (optional)



8101-30

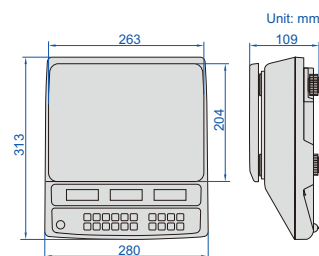

SPECIFICATION

Code	8101-6	8101-15	8101-30	8101-6D	8101-15D	8101-30D
Maximum weighing	6kg	15kg	30kg	6kg	15kg	30kg
Minimum weighing	4g	10g	20g	4g	10g	20g
Resolution (d)	0.2g	0.5g	1g	0.2g	0.5g	1g
Accuracy (m is load)	m≤1kg: ±1g 1kg<m≤4kg: ±2g m>4kg: ±3g	m≤2.5kg: ±2.5g 2.5kg<m≤10kg: ±5g m>10kg: ±7.5g	m≤5kg: ±5g 5kg<m≤20kg: ±10g m>20kg: ±15g	m≤1kg: ±1g 1kg<m≤4kg: ±2g m>4kg: ±3g	m≤2.5kg: ±2.5g 2.5kg<m≤10kg: ±5g m>10kg: ±7.5g	m≤5kg: ±5g 5kg<m≤20kg: ±10g m>20kg: ±15g
Output	no			RS232		
Operation temperature	-10~40°C					
Power	rechargeable battery (6V/3.2Ah), power adapter (12V/500mA)					
Dimensions of pan	263×204mm					

OPTIONAL ACCESSORY (for scales with RS232)

Printer	8001-PRINTER
---------	--------------

ELECTRONIC POCKET SCALE (ECONOMIC TYPE)

ATTENTION:
LOW ACCURACY



8601-100

- LCD display, with backlight
- Zero-setting, subtracting tare value, counting
- Overload alarm
- Automatic power off



use of pan

SPECIFICATION

Code	8601-100
Maximum weighing	100g
Minimum weighing	0.1g
Resolution (d)	0.01g
Accuracy (m is load)	0.1g≤m≤1g: ±0.03g; 1g<m≤30g: ±0.05g 30g<m≤50g: ±0.07g; m>50g: ±0.14g
Units	g, oz, dwt, ozt
Dimension of pan	55×64mm
Dimension (L×W×H)	108×65×21mm
Operation temperature	-10~40°C
Power supply	2×AAA batteries

ELECTRONIC POCKET SCALE (ECONOMIC TYPE)

ATTENTION:
LOW ACCURACY



8602-200

- LCD display, with backlight
- Zero-setting, subtracting tare value, counting
- Overload alarm
- Automatic power off



use of pan

SPECIFICATION

Code	8602-200
Maximum weighing	200g
Minimum weighing	0.2g
Resolution (d)	0.02g
Accuracy (m is load)	0.2g≤m≤2g: ±0.06g; 2g<m≤60g: ±0.1g 60g<m≤100g: ±0.14g; m>100g: ±0.28g
Units	g, oz, dwt, ozt
Dimension of pan	55×64mm
Dimension (L×W×H)	120×70×17mm
Operation temperature	-10~40°C
Power supply	2×CR2032 batteries

WEIGHING SCALES (ECONOMIC TYPE)



8003-3

■ Unit: g, oz, ct, tl

SPECIFICATION

Code	8003-3	8003-6	8003-10
Maximum weighing	3kg	6kg	10kg
Minimum weighing	2g	10g	20g
Resolution (d)	0.1g	0.5g	1g
Accuracy	±0.5g	±2.5g	±5g
Weighing pan size	157×157mm		
Operation temperature	5~35°C		
Power supply	2×AAA batteries, power adapter		
Dimension (L×W)	160×225mm		

PLATFORM SCALES

DATA OUTPUT



8501-AL150

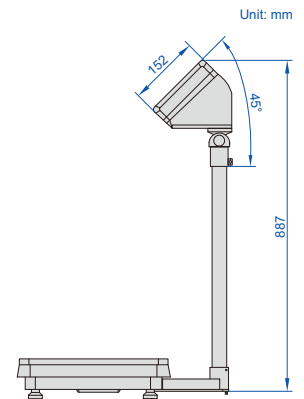
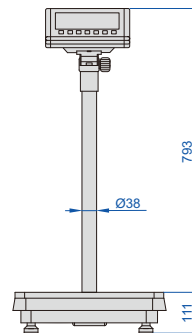
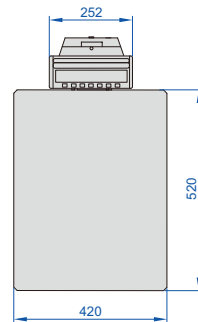

Unit: mm

- LCD large screen display with LED backlight
- Weighing, overweight alarm, counting, keyboard lock, accumulating, auto zero and animal scale
- Units: kg, g, lb, oz

SPECIFICATION

Code	8501-AL60	8501-AL150	8501-AL300
Maximum weighing	60kg	150kg	300kg
Minimum weighing	100g	200g	400g
Resolution (d)	5g	10g	20g
Accuracy	±10g	±20g	±30g
Operation temperature	-10~40°C		
Material	platform: stainless steel, base: die-cast aluminum		
Dimension of platform	420×520mm		
Power	rechargeable lead acid battery (6V/4Ah)		
Output	RS232		
Weight	18.3kg		



printer (optional)

OPTIONAL ACCESSORY

Printer	8001-PRINTER
Data output cable (keyboard format)	7302-8001

FLOOR SCALES

DATA OUTPUT

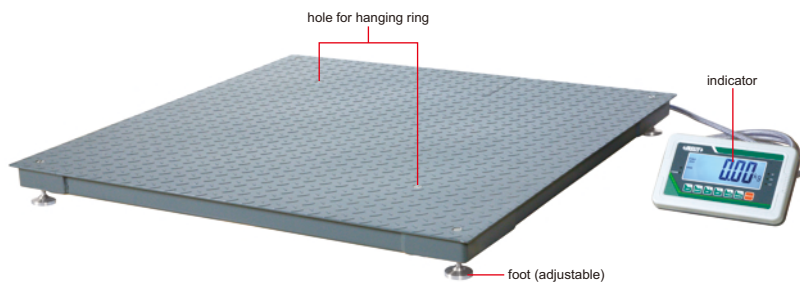

8401-1T1212

- LCD large screen display with automatic backlight
- Zeroing, overweight alarm, deduction, unit conversion, accumulating, animal scale, etc.
- Units: kg, g, lb, oz
- OIML approved load cell

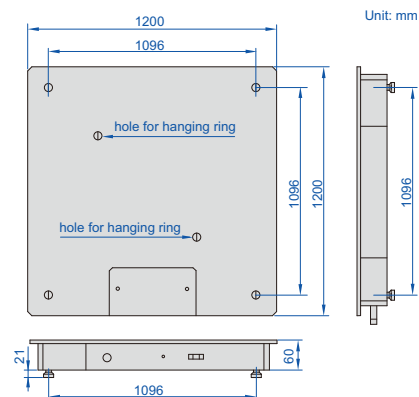
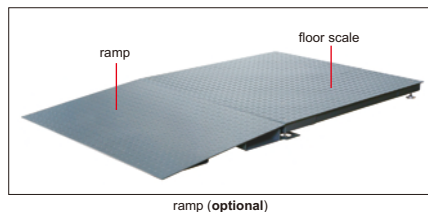
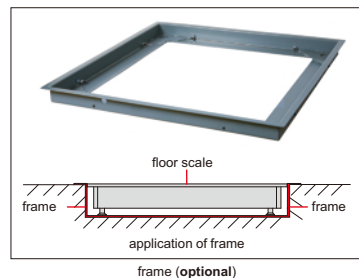

SPECIFICATION

Code	8401-1T1212	8401-2T1212	8401-3T1212
Maximum weighing	1t	2t	3t
Minimum weighing	10kg	20kg	20kg
Resolution (d)	0.5kg	1kg	1kg
Verification interval (e)	0.5kg	1kg	1kg
Accuracy (m is load)	m≤250kg: ±0.25kg; 250kg<m≤1000kg: ±0.5kg	m≤500kg: ±0.5kg; 500kg<m≤2000kg: ±1kg; m>2000kg: ±1.5kg	m≤500kg: ±0.5kg; 500kg<m≤2000kg: ±1kg; m>2000kg: ±1.5kg
Load cell	4 pcs 350Ω		
Operation temperature	-10~40°C		
Material	mild steel		
Dimension of platform	1200×1200mm		
Power	rechargeable lead acid battery (6V/4Ah)		
Output	RS232		
Weight	140kg		



printer (optional)



stand (optional)

STANDARD DELIVERY

Main unit	1 pc
Indicator	1 pc
AC/DC adapter	1 pc
Stainless steel foot	4 pcs
Hanging ring	2 pcs

OPTIONAL ACCESSORY

Ramp	8401-1212-1
Frame	8401-1212-2
Stand	8401-STAND
Printer	8001-PRINTER

ELECTRONIC CRANE SCALES (BASIC TYPE)

- LED display, remote control
- Low voltage indicator
- Unit: kg, lb
- Automatic power off
- Overload alarm
- 360° safe rotary hook and shackle
- Plastic case



Remote controller
(included)



8202-150KG

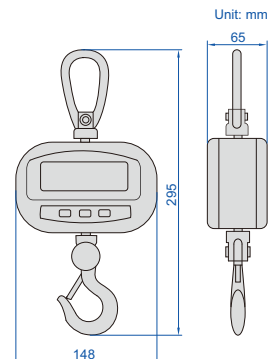

SPECIFICATION

Code	8202-50KG	8202-150KG	8202-300KG
Maximum weighing	50kg	150kg	300kg
Minimum weighing	0.4kg	1.0kg	2.0kg
Resolution (d)	0.02kg/0.01kg	0.05kg/0.02kg	0.10kg/0.05kg
Verification interval (e)	0.02kg	0.05kg	0.10kg
Accuracy	±0.02kg	±0.05kg	±0.10kg
Operation temperature	-10~40°C		
Operation humidity	30%~90% RH		
Overload alarm	100%F.S.+9e		
Maximum safe load	125%F.S.		
Limited overload	400%F.S.		
Power supply	4×1.5V AA batteries (for 40 hours working)		
Stable reading time	≤8s		

STANDARD DELIVERY

Main unit	1 pc
Remote controller	1 pc

ELECTRONIC CRANE SCALES

IP65
WATERPROOF

- Dust/waterproof level: IP65
- LED display, remote control
- Low voltage indicator
- Unit: kg, lb
- Automatic power off
- Overload alarm
- 360° safe rotary hook and shackle
- Aluminum alloy die casting case with high strength



Remote controller
(included)



8201-150KG

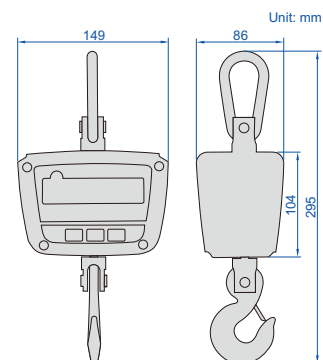

SPECIFICATION

Code	8201-50KG	8201-150KG	8201-300KG
Maximum weighing	50kg	150kg	300kg
Minimum weighing	0.4kg	1.0kg	2.0kg
Resolution (d)	0.02kg/0.01kg	0.05kg/0.02kg	0.10kg/0.05kg
Verification interval (e)	0.02kg	0.05kg	0.10kg
Accuracy	±0.02kg	±0.05kg	±0.10kg
Operation temperature	-10~40°C		
Operation humidity	30%~90% RH		
Overload alarm	100%F.S.+9e		
Maximum safe load	125%F.S.		
Limited overload	400%F.S.		
Power supply	rechargeable battery 6V/3Ah (for 40 hours working)		
Stable reading time	≤8s		

STANDARD DELIVERY

Main unit	1 pc
Remote controller	1 pc
Battery charger	1 pc

ELECTRONIC CRANE SCALES

- Zeroing, taring, weighing
- LED display, remote control
- Low voltage indicator
- Unit: kg, lb
- Overload alarm
- Automatic power off
- Aluminum alloy die casting case with high strength

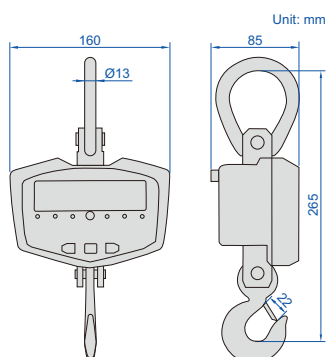

Remote controller (included)



8203-CW05T

SPECIFICATION

Code	8203-CW03T	8203-CW05T	8203-CW1T
Maximum weighing	300kg	500kg	1000kg
Minimum weighing	2kg	4kg	10kg
Resolution (d)	0.1kg/0.05kg	0.2kg/0.1kg	0.5kg/0.2kg
Verification interval (e)	0.1kg	0.2kg	0.5kg
Accuracy (m is load)	m≤50kg: ±0.05kg; 50kg<m≤200kg: ±0.1kg; m>200kg: ±0.15kg	m≤100kg: ±0.1kg; 100kg<m≤400kg: ±0.2kg; m>400kg: ±0.3kg	m≤250kg: ±0.25kg; 250kg<m≤1000kg: ±0.5kg
Overload alarm	100%F.S.+9e		
Maximum safe load	150%F.S.		
Limited overload	400%F.S.		
Stable reading time	<10s		
Power supply	3×1.5V AA batteries		
Operation temperature	-10~40°C		
Operation humidity	30%~90% RH		

STANDARD DELIVERY

Main unit	1 pc
Remote controller	1 pc

MOISTURE ANALYZERS

- LCD screen
- High sensitivity temperature and humidity sensor
- Ring halogen lamp heating evenly, shorten drying time



DATA OUTPUT

SPECIFICATION

Code	8701-RM20	8701-RM30	8701-RM40
Maximum weighing	120g	120g	120g
Resolution (d)	5mg	1mg	0.1mg
Accuracy for moisture	sample<10g	±10%	±0.5%
	sample≥10g	±5%	±0.3%
Accuracy	±0.2%	±0.1%	±0.1%
Operation temperature	13~25°C		
Verification interval	2.5s		
Warm-up time	20~30 minutes		
Weighing pan size	Ø90mm		
Heating source	halogen lamp (450W)		
Range for heating temperature	60~200°C		
Heating time setting	0~99 minutes		
Heating mode	standard heating, step heating, rapid heating		
Shutdown mode	automatic shutdown, manual shutdown, timed shutdown		
Output	RS232C		
Power supply	220V, 50/60Hz		
Dimension (L×W×H)	330×210×340mm		



8701-RM40

calibration weight (included)



STANDARD DELIVERY

Main unit	1 pc
Weight	1 pc

OPTIONAL ACCESSORY

RS232 cable	8304-CABLE*
Printer	8303-PRINTER

*Used to connect with computers



WEIGHT SETS



■ Supplied with manufacturer inspection certificate

8910-5KGF1

CLASS AND MATERIAL

Specification	Code				
	E2 (non-magnetic stainless steel)	F1 (non-magnetic stainless steel)	F1 (304 stainless steel)	F2 (304 stainless steel)	M1 (304 stainless steel)
1mg~100g	8910-100GE2	8910-100GF1	8910-100GF1S	8910-100GF2	8910-100GM1
1mg~200g	8910-200GE2	8910-200GF1	8910-200GF1S	8910-200GF2	8910-200GM1
1mg~500g	8910-500GE2	8910-500GF1	8910-500GF1S	8910-500GF2	8910-500GM1
1mg~1kg	8910-1KGE2	8910-1KGF1	8910-1KGF1S	8910-1KGF2	8910-1KGM1
1mg~2kg	8910-2KGE2	8910-2KGF1	8910-2KGF1S	8910-2KGF2	8910-2KGM1
1mg~5kg	8910-5KGE2	8910-5KGF1	8910-5KGF1S	8910-5KGF2	8910-5KGM1

SPECIFICATION AND SHAPE

Weight	Specification					
	1mg~100g	1mg~200g	1mg~500g	1mg~1kg	1mg~2kg	1mg~5kg
1mg	●	●	●	●	●	●
2mg	● ●*	● ●*	● ●*	● ●*	● ●*	● ●*
5mg	●	●	●	●	●	●
10mg	●	●	●	●	●	●
20mg	● ●*	● ●*	● ●*	● ●*	● ●*	● ●*
50mg	●	●	●	●	●	●
100mg	●	●	●	●	●	●
200mg	● ●*	● ●*	● ●*	● ●*	● ●*	● ●*
500mg	●	●	●	●	●	●
1g	■	■	■	■	■	■
2g	■ ■*	■ ■*	■ ■*	■ ■*	■ ■*	■ ■*
5g	■	■	■	■	■	■
10g	■	■	■	■	■	■
20g	■ ■*	■ ■*	■ ■*	■ ■*	■ ■*	■ ■*
50g	■	■	■	■	■	■
100g	■	■	■	■	■	■
200g		■ ■*	■ ■*	■ ■*	■ ■*	■ ■*
500g			■	■	■	■
1kg				■	■	■
2kg					■ ■*	■ ■*
5kg						■
Quantity	21 pcs	23 pcs	24 pcs	25 pcs	27 pcs	28 pcs
Total range	1mg~211.11g	1mg~611.11g	1mg~1111.11g	1mg~2111.11g	1mg~6111.11g	1mg~11111.11g

● sheet ■ cylinder
 ●* sheet, with mark ■* cylinder, with mark



Salt Spray Testers
Page 300



Temperature And Humidity Chambers
Page 301

SALT SPRAY TESTER CODE SFT-S210R



- Using plastic precision nozzle and conical spray device, the salt spray drops evenly and rapidly, the nozzle has a long working life and does not crystallize
- The spraying time can be controlled internally without external time relay
- The flow rate of salt water and the pressure of compressed air are regulated by flow meter and pressure regulating valve to ensure uniform salt spray settlement
- Manual water adding system can automatically replenish when the water level is insufficient to ensure uninterrupted test

SPECIFICATION

Test condition	suitable for neutral and acid salt spray test
Chamber dimension (WxHxD)	900×500×600mm
Chamber volume	270L
Saline tank volume	25L
Chamber temperature	35±1°C
Saturated barrel temperature	47±1°C
Saline temperature	35±1°C
Heating mode	heat radiation
Spray mode	continuous, intermittent
Test fluid	neutral: purified water+sodium chloride (PH6.5~7.2)
Compressed air pressure	2~3kgf/cm ²
Power supply	AC 220V, 1Ø, 50HZ, 2kW
Dimension (WxHxD)	1560×1250×910mm
Weight	118kg



STANDARD DELIVERY

Main unit	1 pc
Stick	1 group
Sodium chloride	2 bottles
10L salt water preparation measuring cup	1 pc
80ml standard cup	2 pcs
50ml metering cup	2 pcs

OPTIONAL ACCESSORY

Nozzle	SFT-S210R-NOZZLE
Brine Filter	SFT-S210R-FILTER

DESKTOP TEMPERATURE AND HUMIDITY CHAMBER CODE THT-Z158

- Table design, quiet and small
- Equipped with operation system with 7-inch touch screen controller
- Intelligent refrigeration and dehumidification system, it can save 30~45% of electricity compared with traditional machines
- Output excel data report through USB port



SPECIFICATION

Chamber dimension (WxHxD)	300×350×300mm	
Chamber volume	32L	
Temperature range	-40~120°C	
Humidity range	20~98%RH	
Temperature/humidity uniformity	≤2°C, ±3%RH	
Temperature/humidity fluctuation	±0.5°C, ±2.5%RH	
Temperature/humidity stability	±0.3°C, 2.5%RH	
Warm up time	1~3°C/min	
Cooling time	0.7~1°C/min	
Operation environment	environment temperature	5~35°C
	relative humidity	≤85%RH
Material	case material	cold rolled steel plate+varnish
	chamber material	SUS#304 stainless steel
	thermal insulation material	polyurethane foam
Cooling system	compressor	
Protector	compressor overload protection switch, refrigerant high pressure protection switch, ceramic fuse, water plate of water shortage protection switch, electromagnetic switch, air burn protection switch, alarm	
Power supply	AC220, 50/60HZ, 2kW	
Dimension (WxHxD)	550×850×1050mm	
Weight	185kg	



STANDARD DELIVERY

Main unit	1 pc
Test hole	1 pc
Shelf	2 pcs

TEMPERATURE AND HUMIDITY CHAMBERS



THT-A101T

- The chamber is equipped with an independent operation system with 7-inch or 10.1-inch touch screen controller
- Intelligent refrigeration and dehumidification system, combined with energy-saving control algorithm, can adjust the refrigeration level and save energy. Compared with traditional machines, it can save 30~45% of electricity
- It can output excel data report through USB port

SPECIFICATION

Code	THT-A101T	THT-A102T	THT-A103T	THT-A104T	THT-A105T
Chamber dimension (WxHxD)	500×600×500mm	500×500×400mm	500×750×600mm	700×850×700mm	1000×1000×1000mm
Chamber volume	150L	100L	225L	416L	1000L
Temperature range	-40~150°C				
Humidity range	10~98%RH				
Temperature/humidity fluctuation	±0.5°C, ±2.5%RH				
Temperature/humidity uniformity	<2°C, 5%RH				
Temperature/humidity stability	0.2°C, 2%RH				
Temperature/humidity deviation	±2°C, 3%RH				
Warm up time	about 3°C/min				
Cooling time	about 1°C/min				
Material	case material	cold rolled steel plate+varnish			
	chamber material	SUS#304 stainless steel			
	thermal insulation material	rigid polyurethane foam			
Cooling system	compressor				
Protector	no fuse switch, compressor overpressure, overheat protection, overtemperature protection, overload protection, dry burning protection, water shortage protection, etc				
Power supply	AC220V, 50HZ, 4.5kW	AC220V, 50HZ, 2kW	AC380V, 3Ø, 50HZ, 4kW	AC380V, 3Ø, 50HZ, 3.5kW	AC380V, 3Ø, 50HZ, 3.5kW
Dimension (WxHxD)	800×1660×1400mm	750×1550×1170mm	850×1750×1200mm	950×1850×1400mm	1300×1950×1850mm
Weight	365kg	285kg	385kg	510kg	950kg

STANDARD DELIVERY

Main unit	1 pc
Test hole	1 pc
Shelf	2 pcs

CODE NO. INDEX

CODE	PAGE	CODE	PAGE	CODE	PAGE	CODE	PAGE
00		1140.....	27	1240.....	27	2168.....	96
0010.....	226	1141.....	25	1244.....	28	2170.....	152
0020.....	219	1142.....	26	1246.....	97	2171.....	108
01		1143.....	26	1250.....	34	2173.....	151
0110.....	225	1144.....	26	1251.....	34	2174.....	108
0120.....	224	1145.....	28	1253.....	34	2175.....	151
0130.....	227	1146.....	97	1262.....	17	2176.....	108
0131.....	227	1147.....	25	1267.....	70	2179.....	151
0140.....	224	1148.....	26	1273.....	23	2183.....	65
02		1150.....	32	1275.....	137	2188.....	65
0213.....	238	1151.....	33	1281.....	23	2189.....	68
0215.....	238	1154.....	33	1291.....	18	2197.....	64
0222.....	237	1155.....	31	13		2198.....	152
03		1156.....	32	1311.....	9	2199.....	150
0310.....	240	1157.....	31	1312.....	9	22	
0311.....	240	1160.....	127	1316.....	9	2222.....	91
0312.....	241	1161.....	22	1340.....	27	2223.....	91
0313.....	241	1165.....	22	1341.....	27	2275.....	113
0320.....	241	1166.....	138	1351.....	33	2276.....	136
0321.....	239	1169.....	19	1376.....	18	2278.....	136
04		1170.....	8	15		2280.....	112
0411.....	221	1171.....	8	1501.....	66	2281.....	136
0412.....	220	1172.....	22	1520.....	16	2282.....	136
0431.....	222	1176.....	17	1521.....	21	23	
0432.....	221	1177.....	20	1524.....	20	2301.....	78
05		1178.....	17	1525.....	21	2302.....	79
0501.....	228	1180.....	70	1526.....	14~15	2309.....	80
06		1181.....	23	1530.....	15	2310.....	79
0611.....	227	1183.....	19	1531.....	68	2311.....	78
0612.....	228	1185.....	19	1537.....	70	2313.....	78
11		1186.....	22	1539.....	23	2314.....	79
1103.....	6	1187.....	19	1543.....	25	2316.....	80
1106.....	11	1188.....	20	21		2321.....	91
1108.....	7	1189.....	66	2103.....	74	2322.....	58
1110.....	8	1191.....	18	2104.....	74	2324.....	79
1111.....	9	1192.....	20	2108.....	76	2332.....	93
1112.....	7	1196.....	7	2112.....	73	2333.....	92
1113.....	6	1199.....	18	2114.....	75	2334.....	92
1114.....	7	12		2115.....	75	2341.....	28
1115.....	6	1201.....	9	2117.....	76	2342.....	28
1119.....	8	1205.....	10	2133.....	77	2344.....	209
1120.....	17	1214.....	12	2138.....	75	2361.....	93
1121.....	16	1215.....	11	2139.....	75	2363.....	94
1122.....	21	1217.....	10	2140.....	78	2364.....	93
1124.....	16	1223.....	10	2141.....	29	2365.....	93
1125.....	13	1224.....	10	2146.....	97	2367.....	96
1130.....	8	1229.....	23	2147.....	97	2372.....	109
1135.....	11	1233.....	10	2149.....	77	2374.....	109
1136.....	11	1238.....	10	2164.....	96	2380.....	72
1139.....	9	1239.....	11	2166.....	96	2381.....	72

**CODE NO. INDEX**

CODE	PAGE
2383.....	72
2385.....	145
2386.....	72
2397.....	148
2398.....	72
2399.....	72
24	
2480.....	73
25	
2511.....	66
27	
2710.....	95
2711.....	92
2715.....	64
2716.....	63
2771.....	110
28	
2801.....	79
2824.....	59
2825.....	58
2827.....	59
2828.....	58
2840.....	146
2852.....	57
2853.....	57
2862.....	95
2863.....	95
2866.....	94
2870.....	95
2871.....	93
2872.....	93
2873.....	96
2877.....	94
2878.....	95
2879.....	94
29	
2931.....	36
2932.....	37
31	
3101.....	42
3108.....	43
3109.....	43
3127.....	56
3128.....	57
32	
3203.....	44
3205.....	45
3206.....	45
3210.....	44
3220.....	54

CODE	PAGE
3221.....	54
3222.....	54
3227.....	55
3230.....	48
3232.....	49
3233.....	49
3236.....	45
3238.....	50
3240.....	29
3241.....	29
3260.....	49
3261.....	49
3263.....	51
3266.....	49
3281.....	47
3282.....	50
3283.....	50
3285.....	52
3287.....	47
3291.....	48
33	
3331.....	46
3332.....	46
3334.....	96
3350.....	41
3353.....	51
3358.....	42
3359.....	41
34	
3400.....	44
35	
3506.....	46
3520.....	54
3540.....	29
3581.....	48
3594.....	50
40	
4006.....	142
41	
4100.....	99
4101.....	100
4105.....	99
4110.....	101
4118.....	101
4120.....	105
4124.....	104
4130.....	106
4141.....	110
4147.....	113
4158.....	142

CODE	PAGE
4160.....	100
4166.....	101
4180.....	114
4190.....	103
4191.....	114
42	
4206.....	60
4208.....	60
4209.....	69
46	
4601.....	122
4602.....	122
4605.....	122
4621.....	123
4624.....	122
4630.....	127
4676.....	104
47	
4700.....	113
4707.....	111
4721.....	118
4725.....	116
4726.....	117
4728.....	119
4737.....	117
4738.....	119
4739.....	119
4741.....	118
4745.....	113
4770.....	110
4780.....	108
4781.....	109
4782.....	118
4786.....	118
4789.....	116
4790.....	111
4791.....	111
4793.....	112
4796.....	112
4797.....	109
4799.....	109
48	
4801.....	125
4803.....	126
4804.....	125
4806.....	124
4807.....	124
4808.....	126
4809.....	126
4810.....	124

CODE	PAGE
4812.....	124
4820.....	123
4824.....	123
4829.....	135
4830.....	128
4831.....	128
4832.....	129
4833.....	127
4834.....	129
4835.....	130
4836.....	129
4837.....	127
4838.....	130
4839.....	132
4840.....	131
4841.....	132
4842.....	125
4843.....	125
4844.....	70
4845.....	209
4846.....	132
4847.....	129
4848.....	129
4849.....	131
4850.....	131
4851.....	130
4852.....	128
4853.....	126
4854.....	125
4855.....	128
4865.....	68
49	
4902.....	152
4903.....	153
4910.....	153
4911.....	154
4912.....	153
4913.....	154
4914.....	155
4917.....	156
4918.....	155
4920.....	155
4921.....	154
4922.....	154
4923.....	155
50	
5042.....	138
5064.....	133
5071.....	133
5072.....	133

CODE NO. INDEX

CODE	PAGE	CODE	PAGE	CODE	PAGE	CODE	PAGE
51		6230.....	87	7102.....	160	7516.....	196
5103.....	193	6272.....	86	7106.....	83	7517.....	196
5106.....	194	6282.....	80-81	7107-1.....	83	7520.....	196
5108.....	192	6291.....	84	7107-11.....	82	7521.....	196
52		6293.....	84	7107-12.....	82	7522.....	199
5201.....	226	6294.....	84	7107-2.....	83	7523.....	199
53		6295.....	84	7110.....	135	7524.....	198
5302.....	182	6296.....	84	7114.....	60	7525.....	197
5303.....	185	6297.....	84	7118.....	114	7527.....	198
5305.....	195	63		7119.....	135	7528.....	198
5307.....	187	6300.....	52	7120.....	137	7529.....	198
5309.....	188	6301.....	52	7123.....	135	7530.....	199
5311.....	189	6312.....	102	7130.....	82	76	
5313.....	183	6381.....	52	7135.....	61	7600.....	223
5316.....	185	65		7136.....	61	80	
5317.....	186	6520.....	143	7137.....	60	8001.....	292
5318.....	183	6526.....	143	7139.....	134	8002.....	292
57		6531.....	142	7144.....	134	8003.....	294
5700.....	210	6533.....	142	7145.....	134	81	
5701.....	211	6537.....	141	7146.....	134	8101.....	293
5702.....	210	6539.....	141	7160.....	200	82	
58		6556.....	148	7161.....	200	8201.....	296
5801.....	222	6557.....	148	7162.....	200	8202.....	296
5804.....	229	6558.....	146	7163.....	200	8203.....	297
5805.....	229	6562.....	145	7164.....	200	83	
59		6566.....	145	72		8301.....	291
5900.....	229	6567.....	145	7202.....	137	8303.....	290
61		6568.....	145	7203.....	137	8304.....	290
6140.....	13	6582.....	143	7205.....	137	8305.....	291
6141.....	27	6584.....	143	7230.....	138	8310.....	289
6143.....	19	68		7231.....	138	84	
6144.....	12	6801.....	140	7232.....	138	8401.....	295
6145.....	12	6805.....	140	7260.....	133	85	
62		6832.....	131	7261.....	133	8501.....	294
6200.....	87	6841.....	89	7262.....	133	86	
6201.....	87	6843.....	38	73		8601.....	293
6202.....	87	6845.....	89	7302.....	4	8602.....	293
6207.....	87	6846.....	89	7315.....	2~3	87	
6208.....	86	6847.....	38	7331.....	82	8701.....	297
6210.....	85	6852.....	114	7342.....	101	89	
6211.....	87	6876.....	88	7353.....	59	8910.....	298
6216.....	87	6878.....	141	7360.....	77	91	
6219.....	86	6879.....	142	7391.....	48	9132.....	237
6221.....	86	6886.....	100	7394.....	47	92	
6224.....	86	6890.....	140	75		9216.....	232
6225.....	88	6891.....	141	7511.....	197	9223.....	218
6226.....	88	69		7512.....	199	9224.....	219
6227.....	88	6990.....	138	7513.....	198	9225.....	218
6228.....	86	70		7514.....	197	9241.....	232
6229.....	85	7101.....	160	7515.....	197	9242.....	233



CODE NO. INDEX

CODE	PAGE
9246.....	234
9247.....	233
93	
9315.....	235
9331.....	225
9341.....	223
9351.....	226
9353.....	226
9362.....	239
94	
9408.....	161
9410.....	148
9413.....	147
95	
9501.....	207
9511.....	209
9561.....	220
96	
9651.....	231
97	
9720.....	219
9721.....	235
9722.....	235
9723.....	235
99	
9911.....	231
CMM	
CMM-LM□□□.....	169~170
CMM-ST□□□.....	167~168
DSW	
DSW-A010.....	223
GRL	
GRL-L340.....	156
HDT	
HDT-B-□□□.....	271
HDT-CB320.....	263
HDT-L410.....	266
HDT-L411.....	267
HDT-LP200.....	264
HDT-MB610.....	260
HDT-MB710.....	260
HDT-MBE320.....	261
HDT-MVE1300.....	257
HDT-MVH1100.....	256
HDT-RA151.....	255
HDT-RT151.....	252
HDT-RW160.....	255
HDT-VE56.....	259
HDT-VH05.....	258
HDT-VH11.....	258

CODE	PAGE
HDT-VH31.....	258
HDT-VH51.....	258
HDT-WL320.....	263
HDT-WP201.....	265
ISD	
ISD-V150A.....	177
ISD-V220CNCA.....	178
ISD-V250A.....	177
ISD-V300A.....	177
ISD-VMM205D.....	181
ISE	
ISE-2DT.....	150
ISF	
ISF-1DF□□□.....	278
ISF-F□□□.....	279
ISF-MT1K.....	278
ISF-MT500.....	278
ISF-P30A.....	279
ISF-P30D.....	279
ISF-S□□□.....	277
ISF-TG□□□.....	279
ISF-U055.....	277
ISF-U101.....	277
ISF-U202.....	277
ISGF	
ISGF-0901.....	138
ISHB	
ISHB-B300.....	269
ISHB-H131.....	268
ISH	
ISH-BRV.....	262
ISH-DSA.....	270
ISH-DSD.....	270
ISH-DSOO.....	270
ISH-DS-STANDA.....	269
ISH-MRD200.....	253
ISH-RD200.....	254
ISH-SAM.....	270
ISH-SDM.....	270
ISH-STAC.....	270
ISH-STD.....	270
ISHR	
ISHR-P151.....	267
ISHW	
ISHW-H□□□.....	268
ISHW-L20.....	269
ISL	
ISL-B5-100.....	158
ISL-B5-1000.....	158
ISL-B5-300.....	158

CODE	PAGE
ISL-B5-500.....	158
ISL-DR2.....	158
ISL-DR3.....	158
ISL-SET1.....	159
ISM	
ISM-CT820.....	187
ISM-DL301.....	184
ISM-PM100.....	196
ISM-PM200SA.....	190
ISM-WF200.....	191
ISM-ZS100T.....	193
ISM-ZS30.....	195
ISM-ZS50.....	194
ISO	
ISO-1000FN.....	208
ISO-1200FN.....	208
ISO-8000FN.....	206
ISP	
ISP-Z3015.....	174
ISQ	
ISQ-DG6.....	210
ISQ-DRM31.....	222
ISQ-PK100.....	212
ISQ-RM30.....	223
ISR	
ISR-C002.....	246
ISR-C003.....	250
ISR-C300.....	247~248
ISR-CS130-W.....	250
ISR-T120.....	248~249
IST	
IST-04□□□.....	281
IST-11WM□□□.....	285~286
IST-15W□□□.....	284
IST-19WM□□□.....	287
IST-2W□□□.....	282~283
IST-9WM□□□.....	285
IST-DW□□□.....	287
IST-MG□□□.....	281
IST-W□□□.....	282
ISU	
ISU-100D.....	217
ISU-250C.....	217
ISV	
ISV-E30.....	204
ISV-E40.....	204
ISV-K□□□.....	202
ISV-P6.....	203
ISV-S106.....	203
ISV-T105.....	203

CODE	PAGE
ISY	
ISY-100.....	171~172
ISY-200.....	170
ISY-600.....	172
ISY-700.....	179
LDM	
LDM-030.....	161
MLP	
MLP-CM86.....	273
MLP-GP314.....	274
MLP-MP62.....	273
MPI	
MPI-HF360.....	165
MPI-P110.....	165
MPI-P220.....	165
MPI-P330.....	165
PHT	
PHT-C751.....	212
PPF	
PPF-BF62.....	214
QMS	
QMS-A110.....	175
QMS-A220.....	176
QMY	
QMY-AP32.....	213
SFT	
SFT-S210R.....	300
SPM	
SPM-1000.....	243
SPM-2000.....	244
SPM-4000.....	245
SPT	
SPT-AD21.....	213
THD	
THD-PF34.....	214
THT	
THT-A101T.....	301
THT-Z158.....	300
TLP	
TLP-300H.....	162
UFD	
UFD-T680.....	164
UTM	
UTM-E50.....	276



INSIZE INDIA

Block B-09, Sumel-8, Nr. Ajit
Mill Char Rasta, Rakhial
Ahmedabad - 380023, India



www.insize.in



General Catalogue



www.insize.in/Catalogue.html

Promotion Brochure



www.insize.in/Promotion.html

Sales / Technical

- ☎ Mobile: 7819819939
- ☎ Telephone: 7819819941
- ✉ E-mail: ahmedabad@insize.com

Repairing

- ☎ Mobile: 7819819940
- ☎ Telephone: 9624899942
- ✉ E-mail: repair@insize.com

Distributed by:

We reserve the right to change or modify the design and specification of products in this catalogue without prior notice.